



User Manual



Click the link <https://www.ezviz.com/page/hg2-400-choose-language> or scan the QR code to watch the tutorial videos.

www.ezviz.com

COPYRIGHT © Hangzhou EZVIZ Software Co., Ltd. ALL RIGHTS RESERVED.

Any and all information, including, among others, wordings, pictures, graphs are the properties of Hangzhou EZVIZ Software Co., Ltd. (hereinafter referred to as “EZVIZ”). This user manual (hereinafter referred to as “the Manual”) cannot be reproduced, changed, translated, or distributed, partially or wholly, by any means, without the prior written permission of EZVIZ. Unless otherwise stipulated, EZVIZ does not make any warranties, guarantees or representations, express or implied, regarding to the Manual.

About this Manual

The Manual includes instructions for using and managing the product. Pictures, charts, images and all other information hereinafter are for description and explanation only. The information contained in the Manual is subject to change, without notice, due to firmware updates or other reasons. Please find the latest version in the EZVIZ™ website (<http://www.ezviz.com>).

Revision Record

New release – June, 2026

Trademarks Acknowledgement

EZVIZ™, ™, and other EZVIZ’s trademarks and logos are the properties of EZVIZ in various jurisdictions. Other trademarks and logos mentioned below are the properties of their respective owners.

Legal Disclaimer

TO THE MAXIMUM EXTENT PERMITTED BY APPLICABLE LAW, THE PRODUCT DESCRIBED, WITH ITS HARDWARE, SOFTWARE AND FIRMWARE, IS PROVIDED “AS IS”, WITH ALL FAULTS AND ERRORS, AND EZVIZ MAKES NO WARRANTIES, EXPRESS OR IMPLIED, INCLUDING WITHOUT LIMITATION, MERCHANTABILITY, SATISFACTORY QUALITY, FITNESS FOR A PARTICULAR PURPOSE, AND NON-INFRINGEMENT OF THIRD PARTY. IN NO EVENT WILL EZVIZ, ITS DIRECTORS, OFFICERS, EMPLOYEES, OR AGENTS BE LIABLE TO YOU FOR ANY SPECIAL, CONSEQUENTIAL, INCIDENTAL, OR INDIRECT DAMAGES, INCLUDING, AMONG OTHERS, DAMAGES FOR LOSS OF BUSINESS PROFITS, BUSINESS INTERRUPTION, OR LOSS OF DATA OR DOCUMENTATION, IN CONNECTION WITH THE USE OF THIS PRODUCT, EVEN IF EZVIZ HAS BEEN ADVISED OF THE POSSIBILITY OF SUCH DAMAGES.

TO THE MAXIMUM EXTENT PERMITTED BY APPLICABLE LAW, IN NO EVENT SHALL EZVIZ’S TOTAL LIABILITY FOR ALL DAMAGES EXCEED THE ORIGINAL PURCHASE PRICE OF THE PRODUCT.

EZVIZ DOES NOT UNDERTAKE ANY LIABILITY FOR PERSONAL INJURY OR PROPERTY DAMAGE AS THE RESULT OF PRODUCT INTERRUPTION OR SERVICE TERMINATION CAUSED BY: A) IMPROPER INSTALLATION OR USAGE OTHER THAN AS REQUESTED; B) THE PROTECTION OF NATIONAL OR PUBLIC INTERESTS; C) FORCE MAJEURE; D) YOURSELF OR THE THIRD PARTY, INCLUDING WITHOUT LIMITATION, USING ANY THIRD PARTY’S PRODUCTS, SOFTWARE, APPLICATIONS, AND AMONG OTHERS.

REGARDING TO THE PRODUCT WITH INTERNET ACCESS, THE USE OF PRODUCT SHALL BE WHOLLY AT YOUR OWN RISKS. EZVIZ SHALL NOT TAKE ANY RESPONSIBILITIES FOR ABNORMAL OPERATION, PRIVACY LEAKAGE OR OTHER DAMAGES RESULTING FROM CYBER ATTACK, HACKER ATTACK, VIRUS INSPECTION, OR OTHER INTERNET SECURITY RISKS; HOWEVER, EZVIZ WILL PROVIDE TIMELY TECHNICAL SUPPORT IF REQUIRED. SURVEILLANCE LAWS AND DATA PROTECTION LAWS VARY BY JURISDICTION. PLEASE CHECK ALL RELEVANT LAWS IN YOUR JURISDICTION BEFORE USING THIS PRODUCT IN ORDER TO ENSURE THAT YOUR USE CONFORMS TO THE APPLICABLE LAW. EZVIZ SHALL NOT BE LIABLE IN THE EVENT THAT THIS PRODUCT IS USED WITH ILLEGITIMATE PURPOSES.

IN THE EVENT OF ANY CONFLICTS BETWEEN THE ABOVE AND THE APPLICABLE LAW, THE LATTER PREVAILS.

Table of Contents

| | |
|---|-----------|
| Safety Regulations | 1 |
| Overview | 3 |
| 1. Package Contents | 3 |
| 2. Necessary Materials (not provided)..... | 5 |
| 3. Space Requirements | 6 |
| 4. Field of Application | 6 |
| 5. General View of Installation..... | 6 |
| 6. Typical Connection..... | 7 |
| Prerequisites for Installation | 10 |
| 1. Risk Analysis | 10 |
| 1.1 Regulations | 10 |
| 1.2 Specifications of the Gate Opener..... | 10 |
| 1.3 Security Check on the Gate | 10 |
| 1.4 Safety Rules | 11 |
| 2. Risk Elimination..... | 12 |
| 2.1 At the Primary Edge | 12 |
| 2.2 At the Secondary Edge | 12 |
| 2.3 At the Upper Slide | 13 |
| 2.4 Between the Bars of an Openwork Gate and the Pillar | 13 |
| 2.5 Clearance Area..... | 14 |
| Install the Wireless Repeater | 15 |
| 1. Basics | 15 |
| 2. Get the EZVIZ App..... | 15 |
| 3. Choose an Installation Location | 16 |
| 4. Plug in Wireless Repeater..... | 17 |
| 5. Add Wireless Repeater to Your EZVIZ Account..... | 17 |
| 6. Add Gate Opener to Your EZVIZ Account..... | 18 |
| Install the Gate Opener | 19 |
| 1. Basics | 19 |
| 2. Remove the Gate Opener Cover | 21 |
| 3. Fix the Gate Opener to the Ground..... | 22 |
| Install Gear Racks and Limit Sheet Metal | 26 |
| 1. Components Required | 26 |
| 2. Unlock the Gate Opener | 26 |
| 3. Fix the Gear Racks | 27 |
| 4. Fix the Limit Sheet Metal | 28 |
| 5. Lock the Gate Opener | 30 |
| Install the Photocellules | 31 |

| | |
|--|-----------|
| 1. Components Required | 31 |
| 2. Basics of Photocellules | 31 |
| 3. Installation Procedure..... | 31 |
| Install the Alarm Light..... | 34 |
| 1. Components Required | 34 |
| 2. Basics of Alarm Light..... | 34 |
| 3. Installation Procedure..... | 34 |
| Install Other Components (Optional)..... | 39 |
| 1. Connect to Intercom Panel, Push Button or Key Switch..... | 39 |
| 2. Connect to Customized Open Controller | 40 |
| 3. Connect to Stop Sensor or Emergency Stop Button | 40 |
| 4. Connect to Electric Strike Plate..... | 42 |
| 5. Connect to Area Lighting | 42 |
| Preparatory Configuration | 44 |
| 1. Wire Check..... | 44 |
| 2. Power On the Gate Opener | 44 |
| 3. Set the Gate-Opening Direction | 45 |
| 4. Add the Remote Controller | 46 |
| 5. Test the Photocellules | 48 |
| 6. Test Gate Opening/Closing | 49 |
| 7. Install the Backup Battery..... | 50 |
| 8. Close the Gate Opener Cover | 51 |
| Settings..... | 52 |
| 1. Wireless Repeater Management..... | 52 |
| 1.1 Detail Page of Wireless Repeater | 52 |
| 1.2 Wireless Repeater Settings | 52 |
| 1.3 Binding a New Wireless Repeater..... | 53 |
| 2. Gate Opener Management | 55 |
| 2.1 Detail Page of Gate Opener..... | 55 |
| 2.2 Gate Opener Settings..... | 57 |
| 2.3 Speaker Settings | 62 |
| Error Codes..... | 64 |
| Technical Data..... | 66 |
| Warranty | 68 |
| Help & Support | 69 |
| Appendix..... | 70 |
| 1. Rechargeable Lithium Ion Battery | 70 |
| 2. Information for Private Households | 70 |

Safety Regulations

We reserve the right to make any modifications to the technical, functional, or aesthetic characteristics of our products. This sliding gate opener (hereinafter referred to as the "gate opener" or "device"), along with its user manual, has been designed to automate gate operation while complying with current European standards.

Precautions for use

- A gate opener is a product that can pose risks to people, animals, and property. For personal safety, it is essential to follow and retain these instructions.
- This device is suitable for use by children aged 8 years and older, as well as by individuals with reduced physical, sensory, or mental capabilities or limited experience and knowledge, provided they are under proper supervision, have been given instructions for safe use, and understand the associated risks. Children should not play with the device. Keep remote controls out of reach of children. Cleaning and maintenance should not be performed by children without supervision.
- This device must only be used for its intended purpose, which is to motorize a sliding gate for vehicle access. Any other use is considered dangerous.
- Gate opening or closing operations must be performed with clear visibility of the gate. If the gate is out of the user's line of sight, the installation must be equipped with a safety device, such as photocells, and its proper functioning must be checked every six months.
- All potential users must be trained in the use of the gate opener by reading this manual. It is essential to ensure that no untrained person (such as a child) can operate the gate.
- Before moving the gate, ensure that no one is in the gate's movement area.
- Avoid any natural obstacles (such as branches, stones, tall grass, etc.) that could impede the gate's movement.
- Do not manually operate the gate when the gate opener is not disconnected from the gate.
- Use of the device not in accordance with the instructions in this manual and resulting in damage will not hold the company EZVIZ responsible.

Installation precautions

- Read this manual thoroughly before beginning installation.
- The power supply for this gate opener must comply with current standards (including NFC 15-100, LVD 2014/35/EU, and Machinery Directive 2006/42/EC) and must be performed by qualified personnel.
- The 230 V mains electricity supply must be protected by a suitable circuit breaker that meets current standards.
- All electrical connections must be made with the power off (protective trip in the OFF position) and the battery disconnected.
- Ensure that crushing and shearing between the moving parts of the motorized gate and the surrounding fixed parts are avoided or clearly signaled during the installation.
- The gate opener must be installed on a gate that meets the specifications outlined in this manual.
- The gate opener must not be installed in an environment with explosive conditions (e.g., presence of gas, flammable smoke, etc.).
- The installer must verify that the installation environment meets the temperature range requirements specified on the gate opener.
- The wire serving as the antenna must remain inside the electronic box.
- It is strictly prohibited to modify any of the components supplied in this kit or to use any additional elements not recommended in this manual.
- During installation, and especially during the adjustment of the gate opener, it is imperative to ensure that no person, including the installer, is in the movement zone of the gate at the start and throughout the duration of the adjustment.
- The alarm light is an essential safety feature.
- If the installation does not match any of the cases described in this manual, it is essential to contact us so we can provide all the necessary elements for a

safe and proper installation.

- After installation, ensure that the mechanism is correctly adjusted and that the protection systems, as well as the manual release device, are functioning properly.
- Do not allow children to play with fixed control devices. Keep remote control devices out of reach of children.
- The EZVIZ company cannot be held responsible for any damage if the installation is not carried out as specified in this manual.

Maintenance and cleaning

- It is essential to carefully read all the instructions provided in this manual before performing maintenance or cleaning on the gate opener.
- Disconnect the power supply during cleaning or maintenance operations, especially if the unit is controlled automatically.
- Any technical, electronic, or mechanical modifications to the gate opener must be approved by our technical department. Otherwise, the warranty will be immediately voided.
- In the event of a malfunction, the faulty part must be replaced with an original part only.
- Frequently inspect the installation to detect any defects in the gate or gate opener.
- Do not clean the product with abrasive or corrosive substances.
- Do not clean the product with a high-pressure cleaner.
- Use a simple, slightly damp soft cloth for cleaning.
- Do not spray this gate opener with an aerosol, as it could damage the interior components.

Battery usage warnings

- Disposing of a battery in a fire or a hot oven, or mechanically crushing or cutting a battery, can result in an explosion.
- Leaving a battery in an extremely high-temperature environment can lead to an explosion or the leakage of flammable liquid or gas.
- A battery exposed to extremely low air pressure may also result in an explosion or the leakage of flammable liquid or gas.

Overview

1. Package Contents

Gate Opener and Accessories

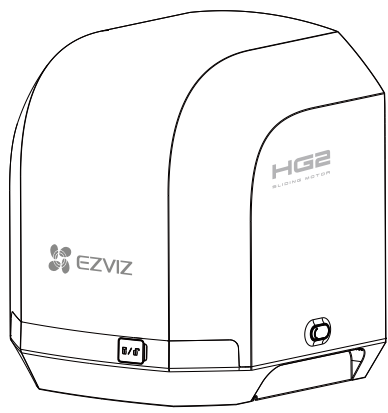

Sliding Gate Opener (x1)

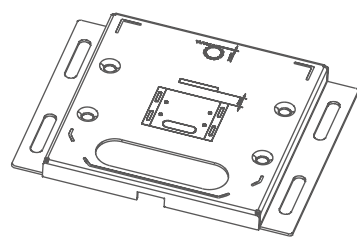

Mounting Base (x1)

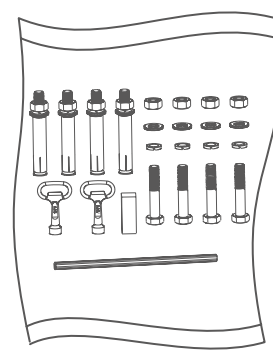

Screw Kit (x1) *

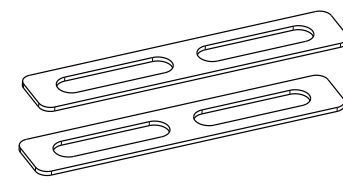

Shim (x2)

Alarm Light and Accessories

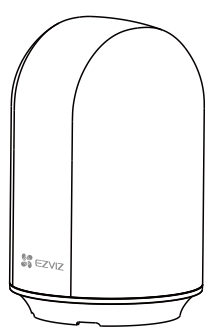

Alarm Light (x1)

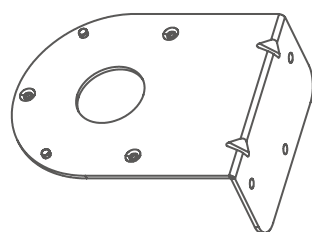

Wall Bracket (x1)

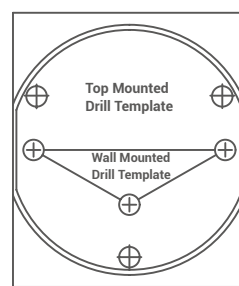

Drill Template (x1)

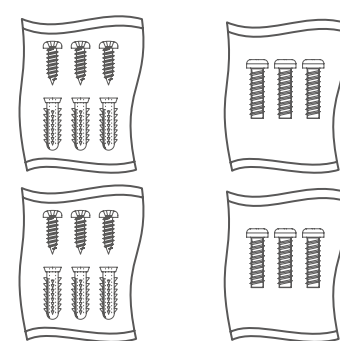

Screw Kit (x4) *

Gear Racks

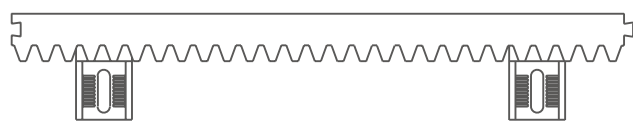

Gear Rack (0.33m x 12)

Photocellules and Accessories

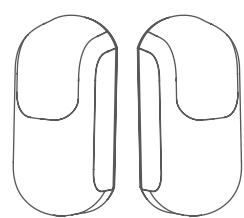

Photocellule (x2)

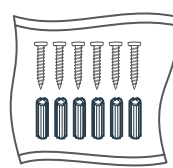

Screw Kit (x1) *

Others

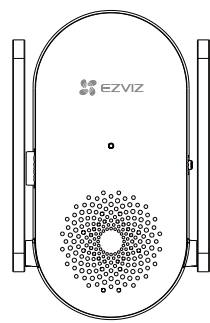

Wireless Repeater (x1)

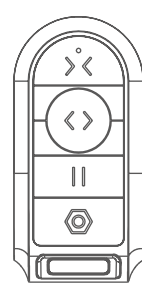

Remote Controller (x2) & Pin (x1)

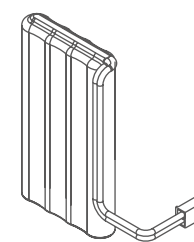

Backup Battery (x1)

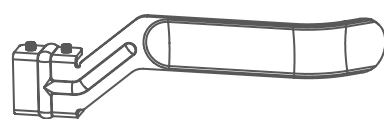

Left Limit Sheet Metal (x1)

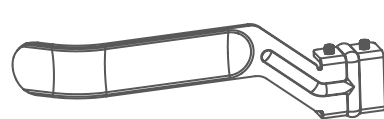

Right Limit Sheet Metal (x1)

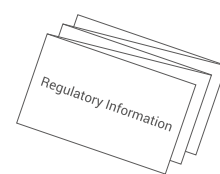

Regulatory Information (x5)



Quick Start Guide (x1)

Screw Kit of the Sliding Gate Opener

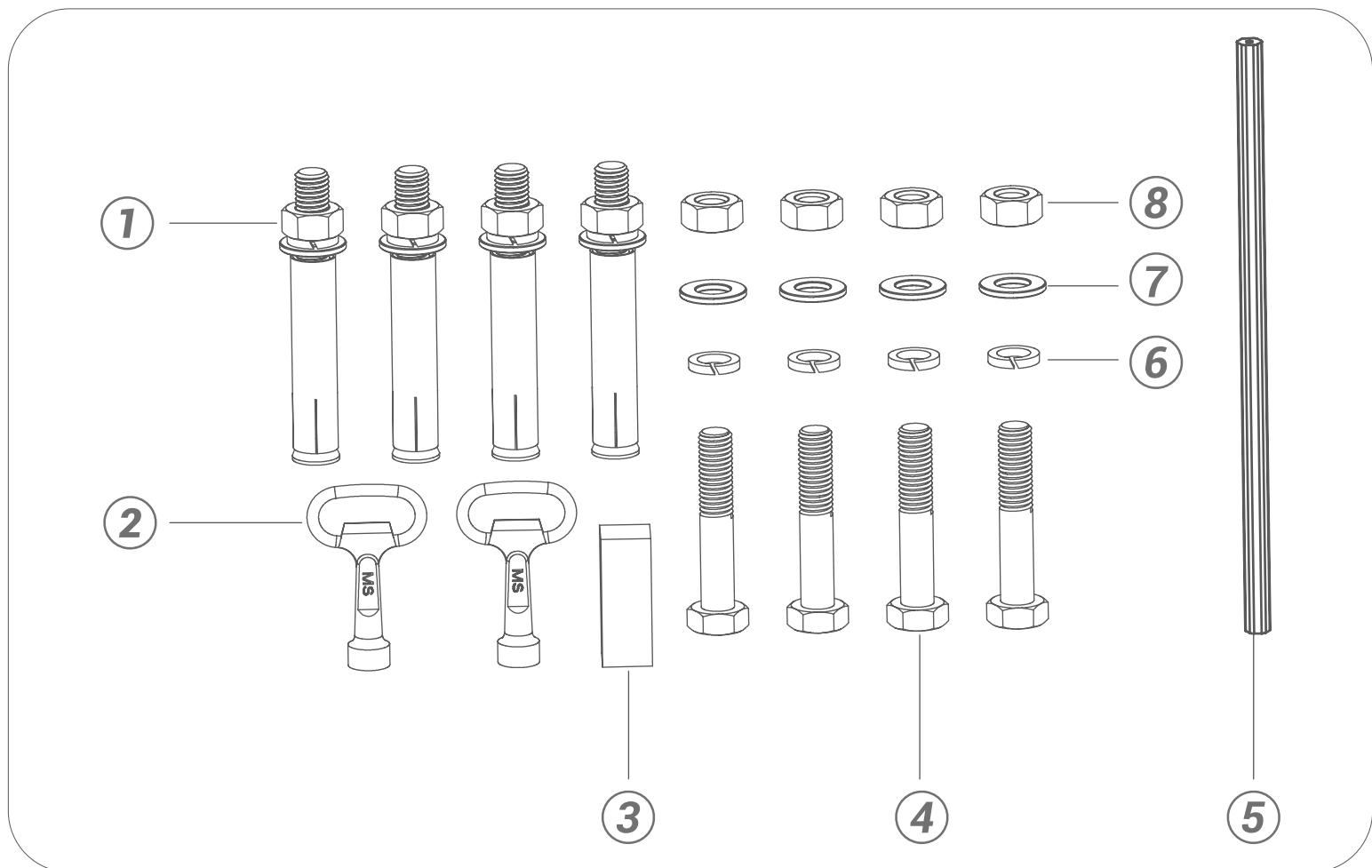

| No. | Name | Quantity |
|-----|---------------------|----------|
| 1 | M10 Expansion Screw | 4 |
| 2 | Key | 2 |
| 3 | Mini Level | 1 |
| 4 | M10 Hexagonal Screw | 4 |
| 5 | Pencil | 1 |
| 6 | M10 Elastic Washer | 4 |
| 7 | M10 Flat Washer | 4 |
| 8 | M10 Nut | 4 |

Screw Kit of the Alarm Light

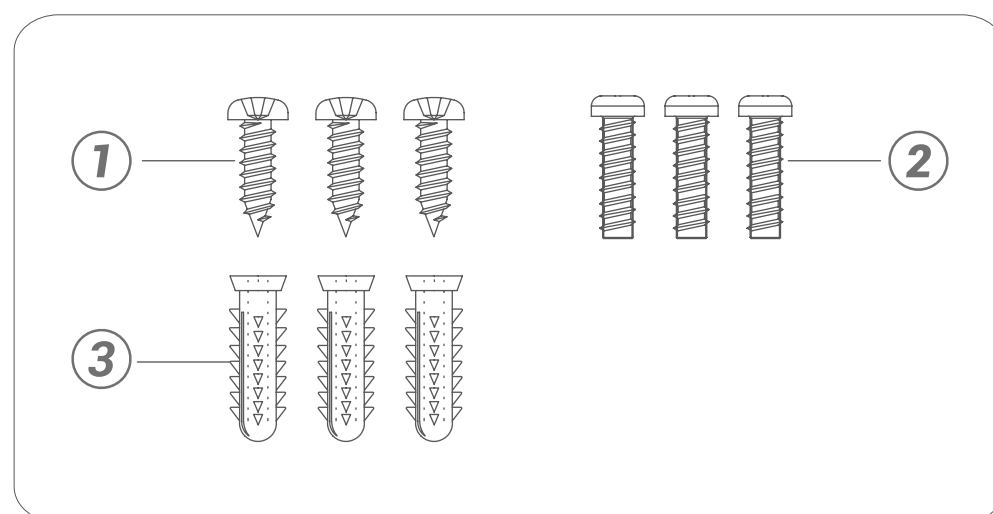

| No. | Name | Quantity |
|-----|---------------------------|------------|
| 1 | PA3×25 Self-tapping Screw | 3 per pack |
| 2 | M3×12 Pan-head Screw | 3 per pack |
| 3 | 6×25 Anchor | 3 per pack |

Screw Kit of the Photocellule

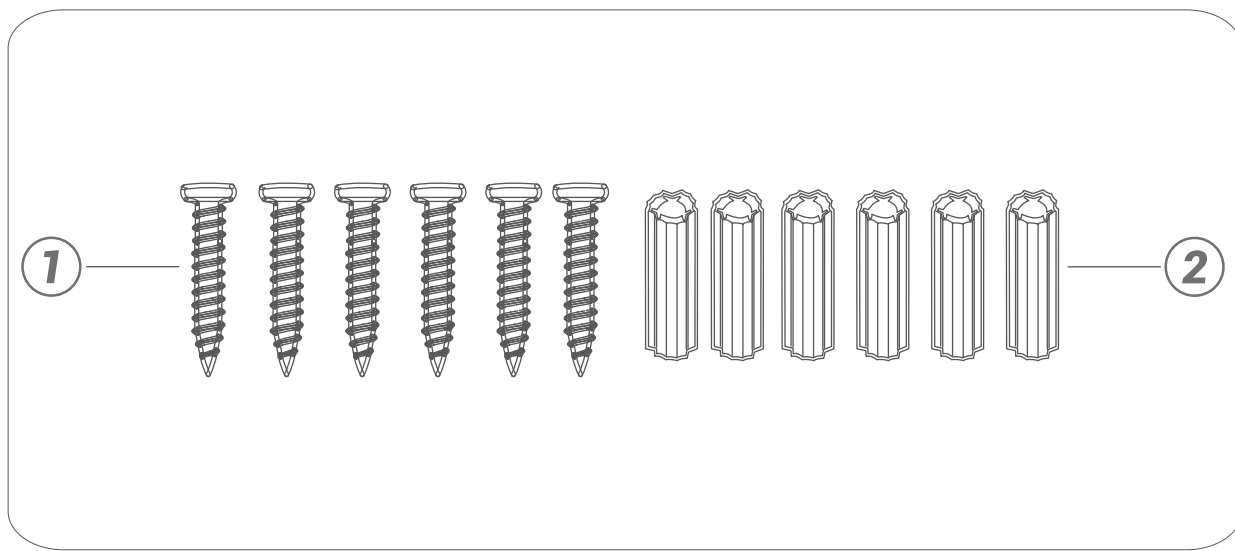

| No. | Name | Quantity |
|-----|----------------------------|----------|
| 1 | KA3×20 Self-drilling Screw | 6 |
| 2 | 6×25 Anchor | 6 |

2. Necessary Materials (not provided)

The tools required for installation must be in good condition and comply with current safety standards.

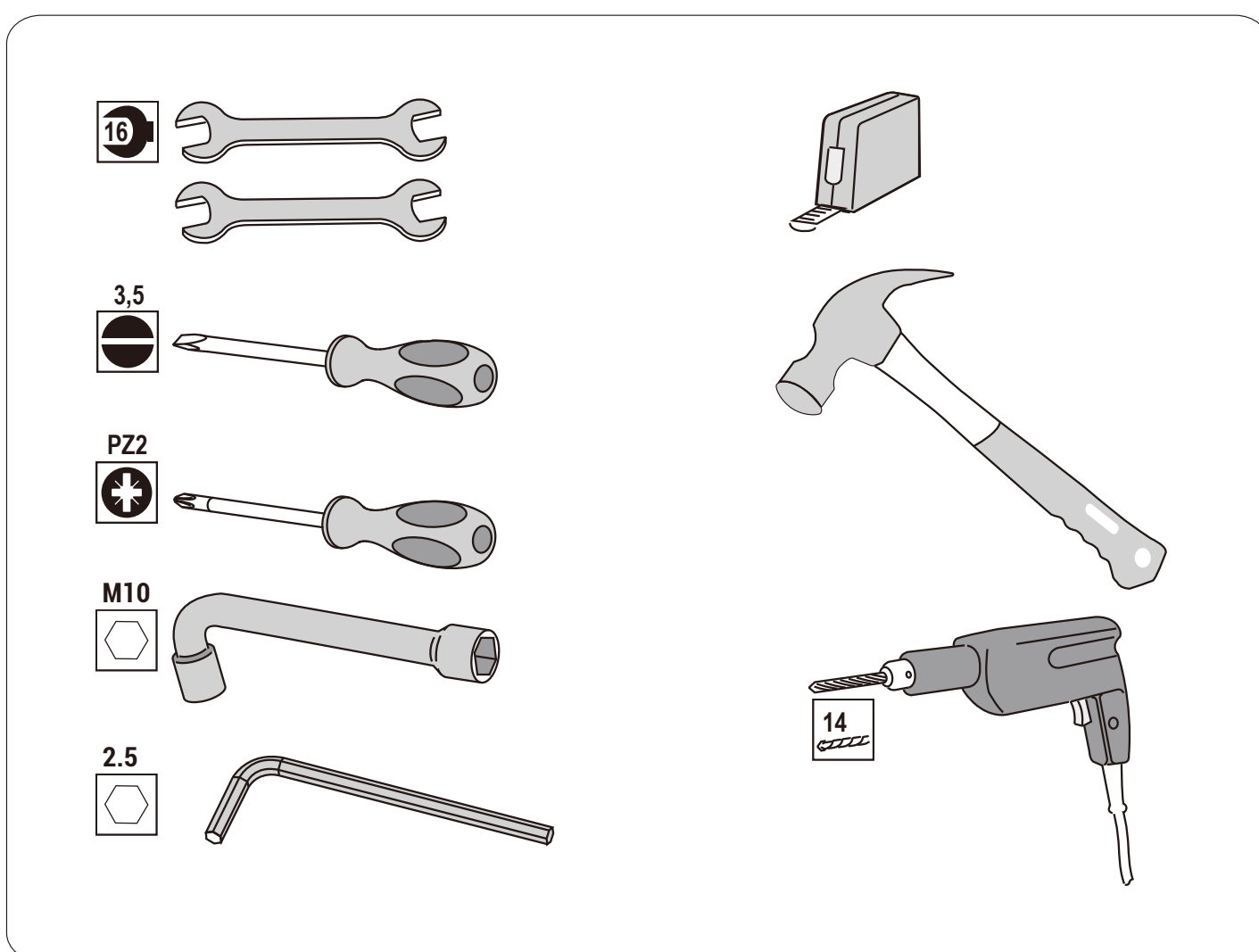

The cables used must be chosen for outdoor use. The passage of cables between the two pillars must comply with current standards. Recommended cable specifications are listed in the table below.

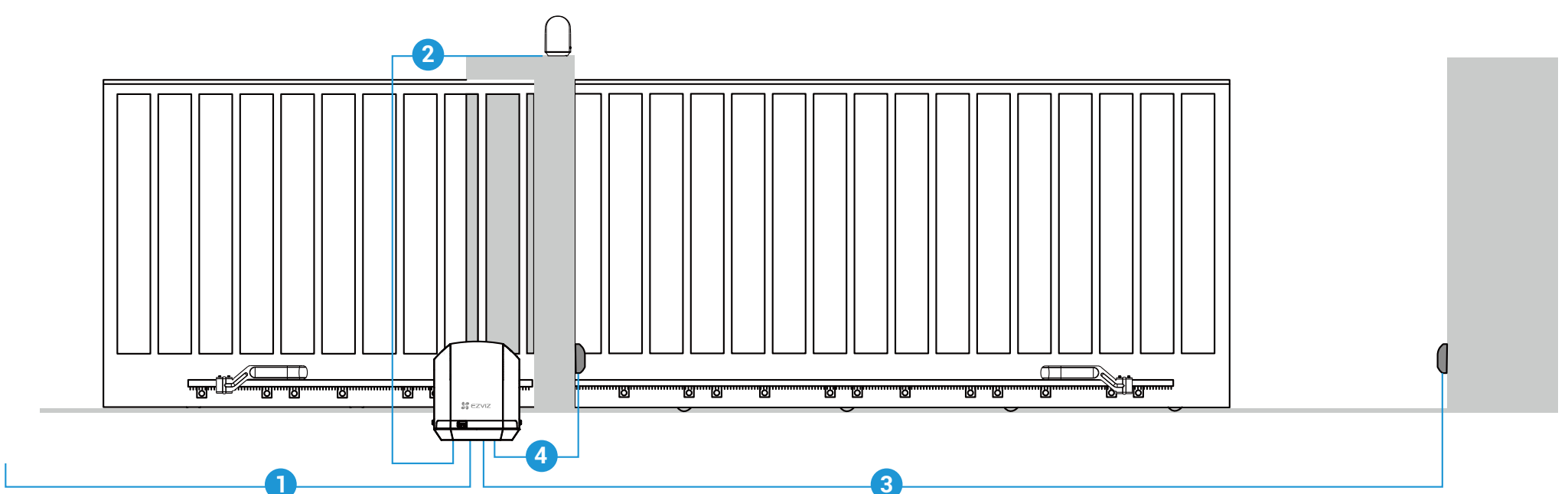

| No. | Connection | Cable | Max Length |
|-----|-------------------------------|-----------------------|-------------|
| 1 | AC 230V Power Supply | 3×1.5mm ² | Not Limited |
| 2 | Alarm Light | 2×0.75mm ² | 10m |
| 3 | Photocellule Transmitter (TX) | 2×0.75mm ² | 10m |
| 4 | Photocellule Receiver (RX) | 2×0.75mm ² | 10m |

3. Space Requirements

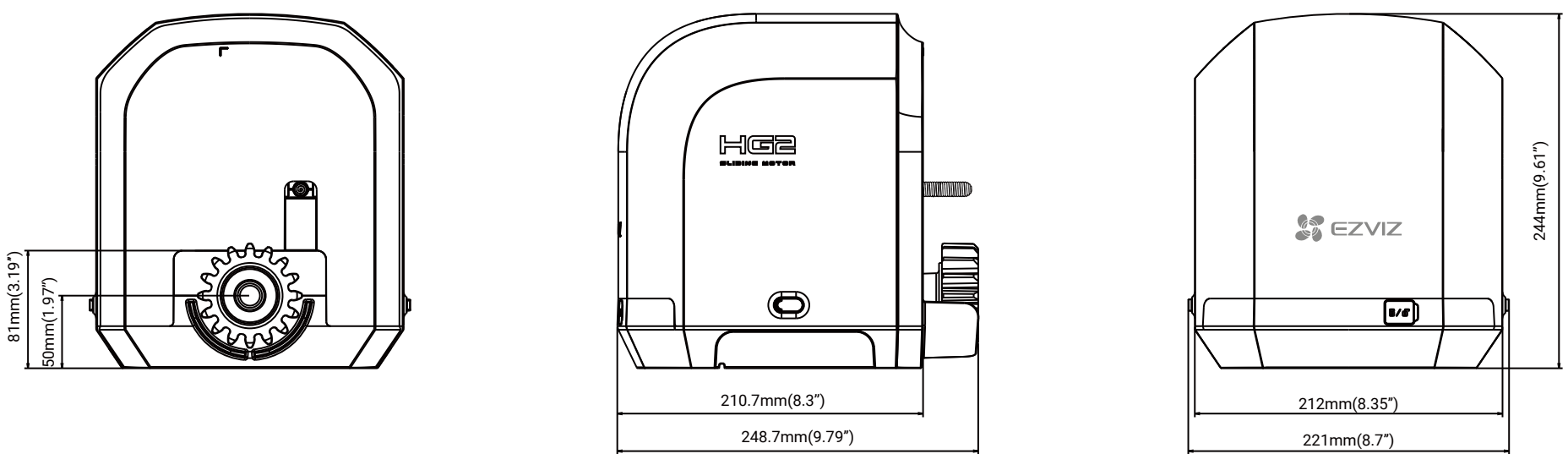

* Unit: mm (inch)

4. Field of Application

This product is intended for the driving of a sliding gate:

- with a max. length of 6m and a max. weight of 400kg
- in PVC, wood or metal
- for a detached house

5. General View of Installation

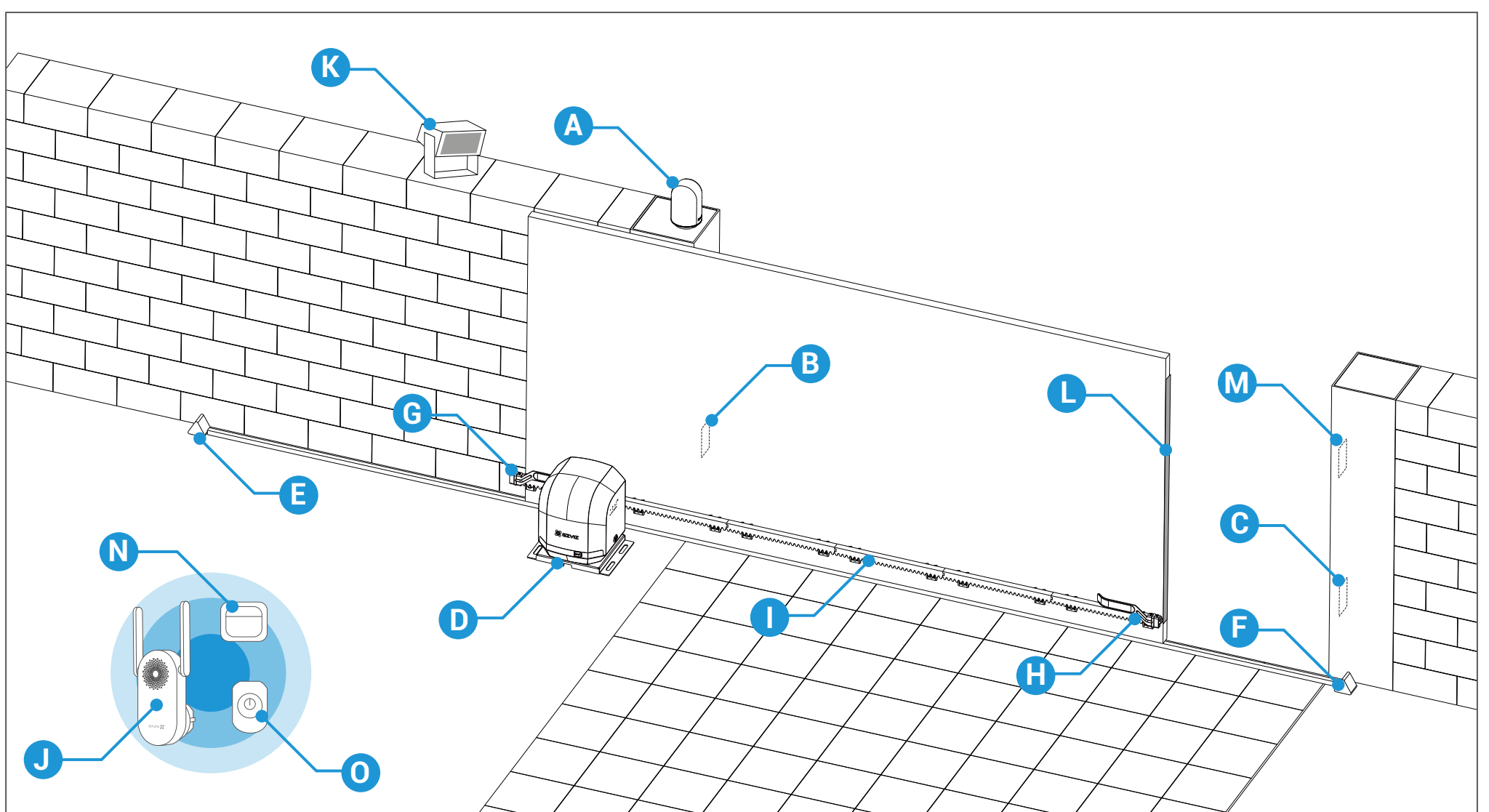

| No. | Name | No. | Name |
|-----|-------------------------|-----|-------------------|
| A | Alarm Light | I | Gear Racks |
| B | Photocellule TX (or RX) | J | Wireless Repeater |
| C | Photocellule RX (or TX) | K | Area Lighting * |
| D | Gate Opener | L | Force Limiter * |
| E | Opening End Stop * | M | Intercom Panel * |
| F | Closing End Stop * | N | Push Button * |
| G | Left Limit Sheet Metal | O | Key Switch * |
| H | Right Limit Sheet Metal | | |

* indicates the component is not included in the package.

6. Typical Connection

It is recommended to route the cables before starting the installation.

Cable routing must comply with current standards. Either the cable is 80cm deep with a red signaling fence, or the cable is passed through a sheath.

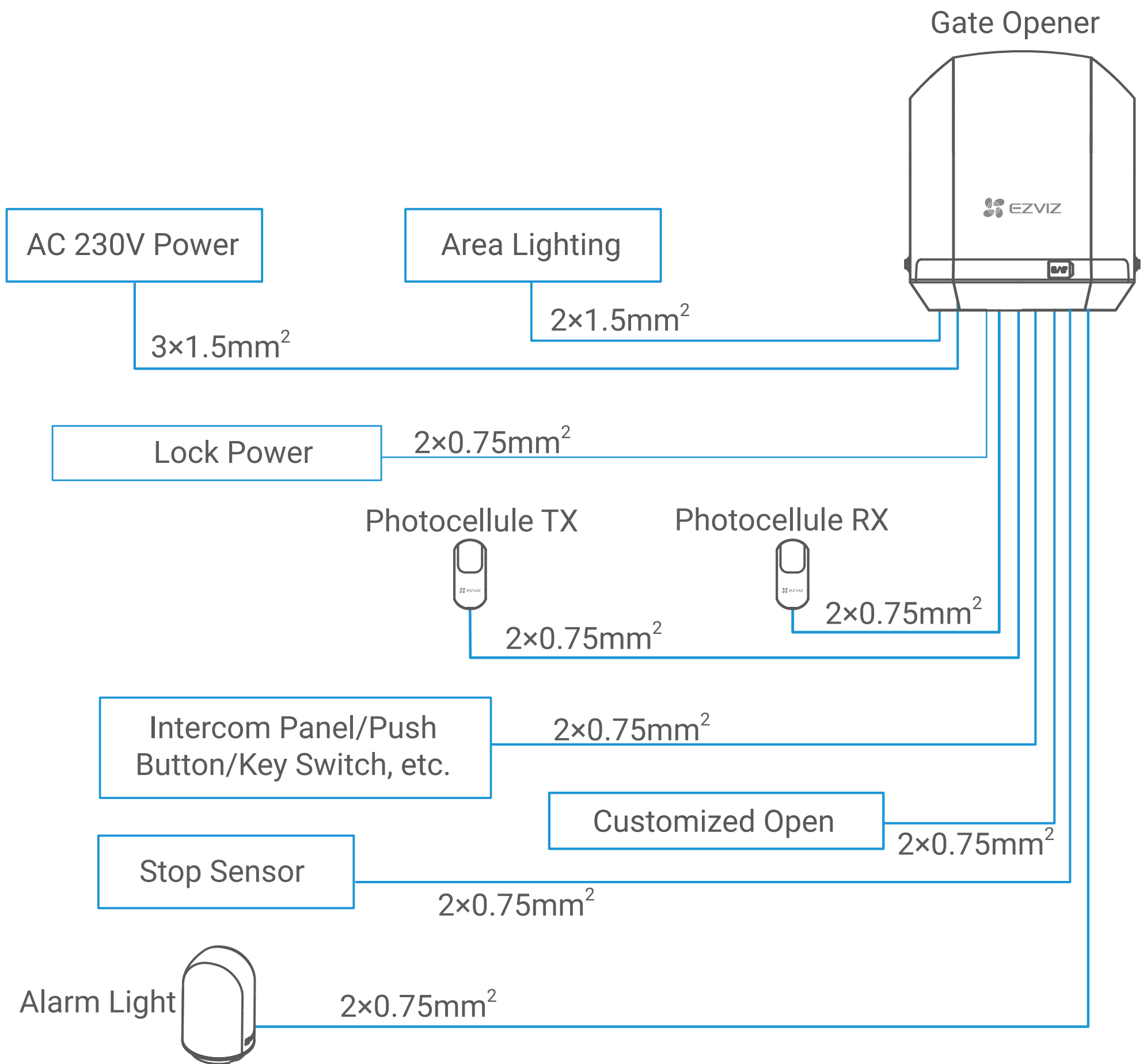

The "Cable connection instructions" label (on top of the gate opener) describes connections of the terminal blocks, as listed in the table below.

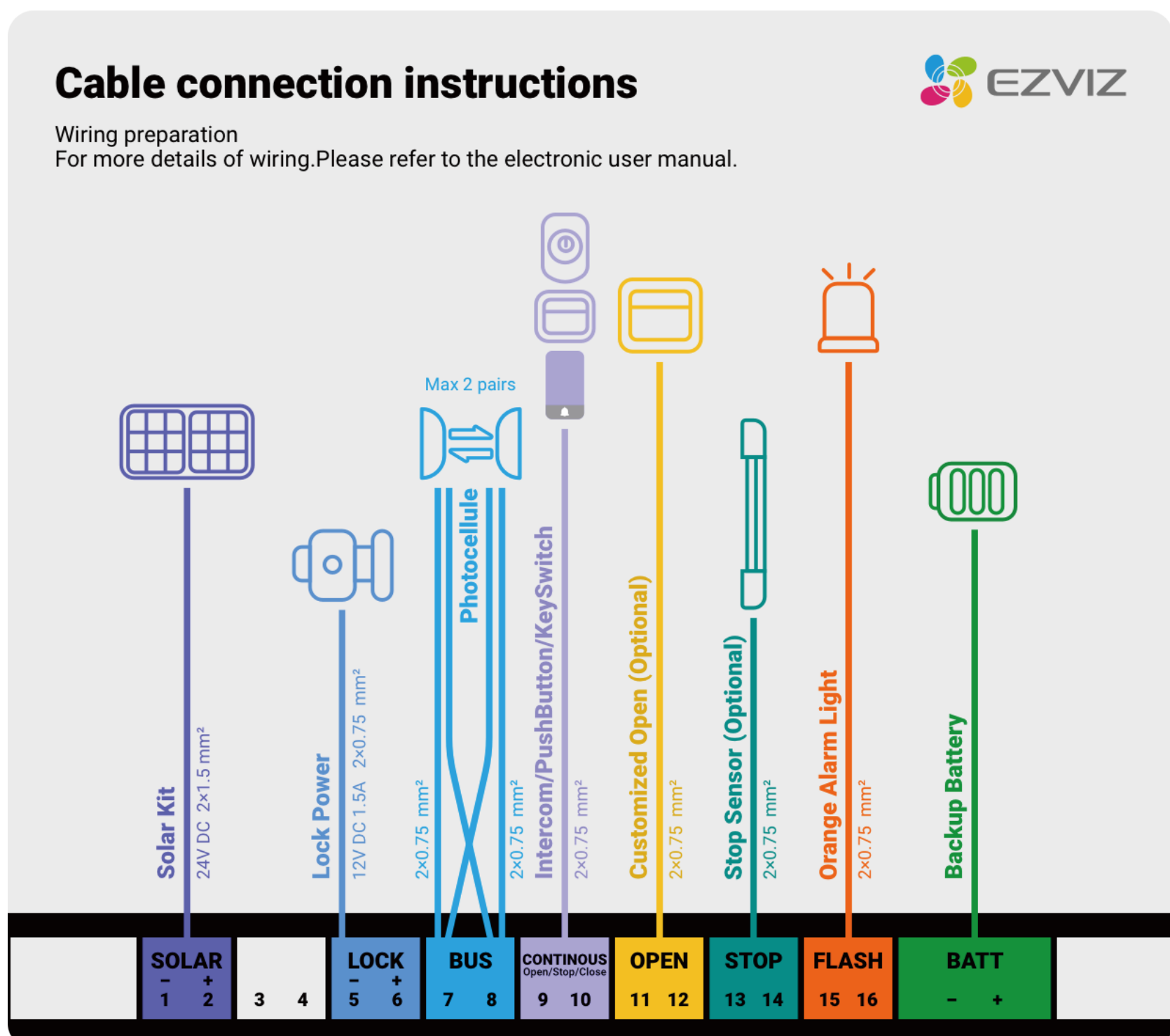

| Terminals | Name | Description |
|-----------|-----------------|---|
| 1 & 2 | SOLAR | Used to connect to the 24V solar kit. i Pay attention to polarity when connecting cables. |
| 3 & 4 | Reserved | |
| 5 & 6 | LOCK | Used to supply 12V DC power to an electric strike plate (without providing control signals). i Pay attention to polarity when connecting cables. |
| 7 & 8 | BUS | Used to connect to photocellules. i A maximum of 2 pairs of photocellules can be connected simultaneously. (The second pair is sold separately.) |
| 9 & 10 | CONTINUOUS | Used to connect to intercom panels, push buttons, or key switches to control the gate in the "Open-Stop-Close" sequence. |
| 11 & 12 | OPEN (Optional) | Used to connect to external control signals to open the gate. You can customize the opening mode (including 1/4 Open, 1/2 Open, 3/4 Open, and Fully Open) in the EZVIZ App. |
| 13 & 14 | STOP (Optional) | Used to connect to external control signals, such as a stop sensor. When hitting an obstacle, the gate will stop immediately. |
| 15 & 16 | FLASH | Used to connect to the alarm light. |
| | BATT- & BATT+ | Used to connect to the backup battery. i Pay attention to polarity when connecting cables. |



| Name | Description | |
|--------------|---|---|
| LIGHT | N | Used to connect to the neutral wire for area lighting. |
| | Lout | Used to connect to the live wire for area lighting. |
| 230V | N | Used to connect to the neutral wire of the power cable. |
| | L | Used to connect to the live wire of the power cable. |
| Earthing Rod | Used to connect to the earth wire of the power cable. | |

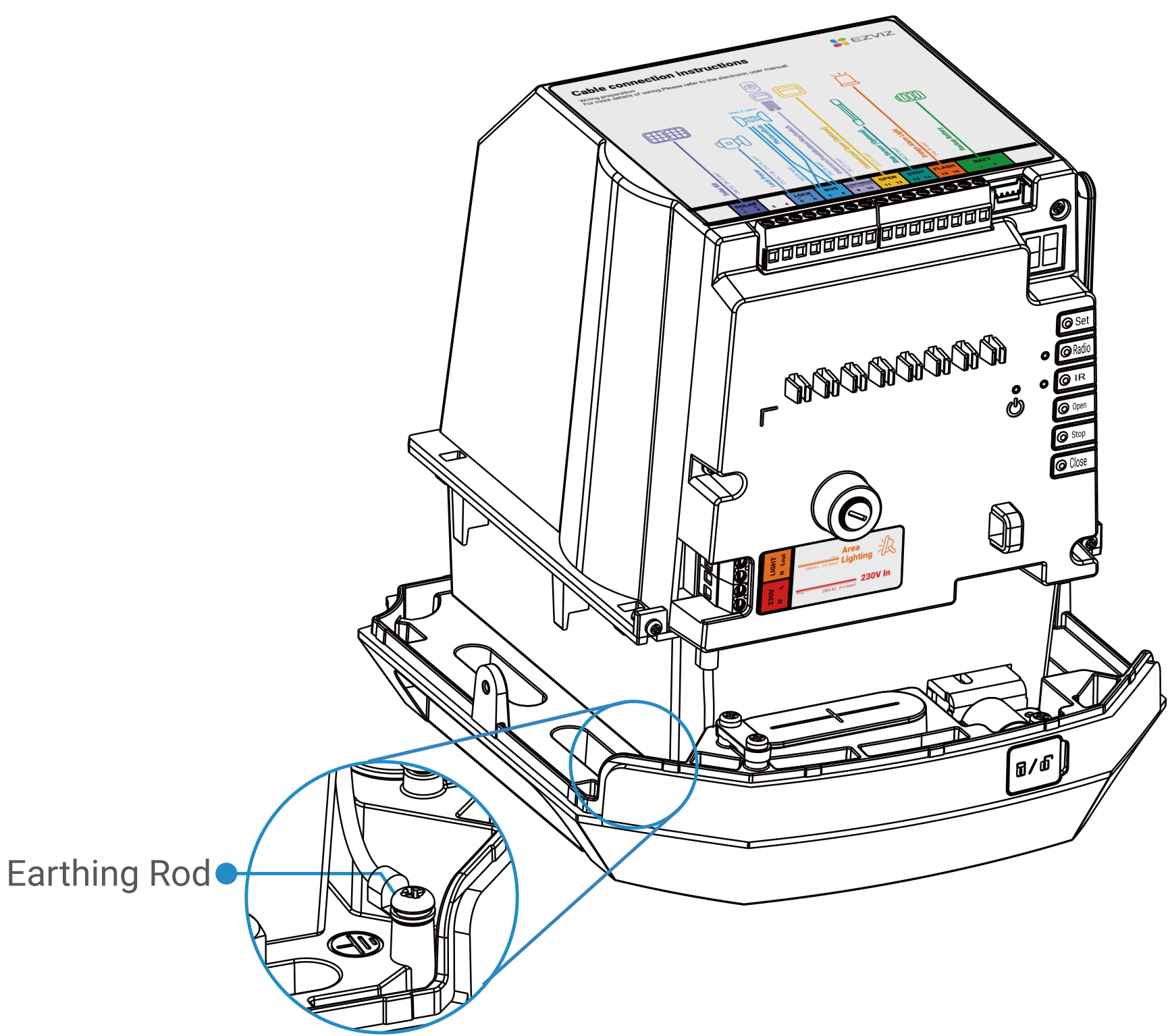

Earthing Rod ●

Prerequisites for Installation

1. Risk Analysis

1.1 Regulations

The installation of the gate opener on a sliding gate as part of a “Residential” type of use must comply with Regulation (EU) No 305/2011 concerning construction products.

The reference standard used to verify this conformity is EN 13241-1 which uses a repository of several standards including EN 12453 which specify the methods and components for securing the motorized gate in order to reduce or completely eliminate dangers for people.

The installer must train the end user in the proper operation of the gate opener, and the trained user must train, using this guide, other people likely to use the gate opener.

It is specified in standard EN 12453 that the minimum protection of the primary edge of the gate depends on the type of use and the type of control used to set the gate in motion.

The gate opener is a pulse-controlled system, meaning that a simple pulse on one of the control elements (remote controller, key switch, etc.) sets the gate in motion.

The specifications of the EN 12453 standard therefore allow the following 3 use cases as well as the minimum protection levels:

- Impulse actuation with visible gate
 - Force limiter only.
- Impulse actuation with non-visible gate
 - Force limiter and 2 pairs of photocellules to protect the opening and closing of the gate.
- Automatic control (automatic closing with time delay)
 - Force limiter and 1 pair of photocellules to protect automatic closing.

The alarm light is an essential safety element.

Safety devices such as photocellules and the proper operation of these must be checked every six months.

1.2 Specifications of the Gate Opener

This gate opener can automate sliding gates measuring up to 6m long and weighing up to 400kg.

1.3 Security Check on the Gate

The gate opener is strictly reserved for residential use. The gate must not be installed in an explosive or corrosive environment (presence of gas, flammable smoke, steam or dust).

- The gate must not be equipped with security systems locking (strike, lock, latch, etc.).
- The guide rail must be perfectly straight, horizontal and correctly fixed to the ground.
- The gate rail and wheels must have a compatible shape and dimensions to guarantee good fluidity of the gate movement and to eliminate any risk of gate derailment.
- The gate must be stopped when opening and closing by stops firmly fixed to the ground so that its travel is limited and above all in order to eliminate any

risk of the gate derailing.

- The installation block where the gate opener will be fixed must not be subject to flooding. Otherwise, plan to raise the installation block.
- Check that the gate is in good mechanical condition, correctly balanced, and can open and close without resistance. It is advisable to lubricate the guide rollers and the supporting wheels.
- Check that the fixing points of the various elements are located in places protected from shocks and that the surfaces are sufficiently solid.
- Check that the gate does not have any protruding parts in its structure.
- If the gate is of the openwork type, it is imperative to place a mesh or a protective net so that no element can pass through the bars of the gate when it is moving or to place a force limiter on each shear zone.
- The gate must comply with the requirements given in standard EN 13241-1.
- If the installation does not correspond to one of the cases indicated in this guide, contact us so that we can provide all the necessary elements for a good installation without risk of damage.

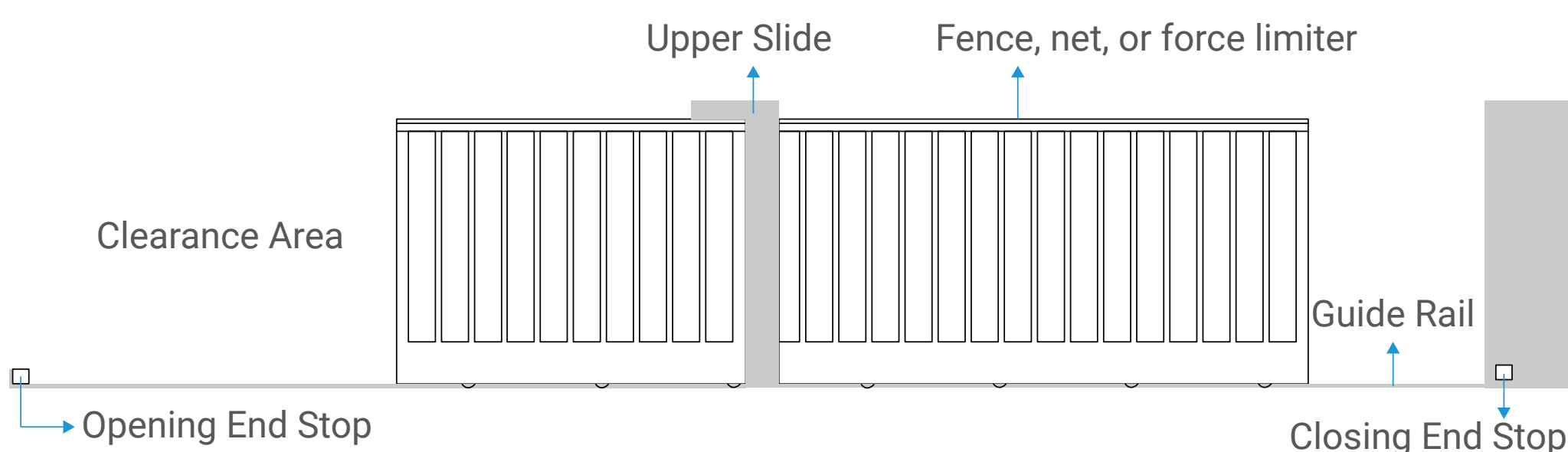

1.4 Safety Rules

EN 12453 specifies performance requirements relating to the safety of use of all types of motorized gates and barriers which are intended to be installed in areas accessible to people, and whose main intended use is to enable access of goods and vehicles accompanied or driven by people, in complete safety, to industrial, commercial or residential premises.

The actual movement of a gate can create dangerous situations for nearby people, goods and vehicles which, by their nature, cannot always be avoided by design.

Possible risks depend on the condition of the gate, how it is used and the installation site.

After checking that the gate is compliant and before starting the installation, it is imperative to carry out a risk analysis of the installation in order to eliminate any dangerous situation or to inform the user of dangerous situations which cannot be avoided.

The risks generated by a motorized sliding gate as well as the solutions adopted to eliminate them are located in the diagram below.

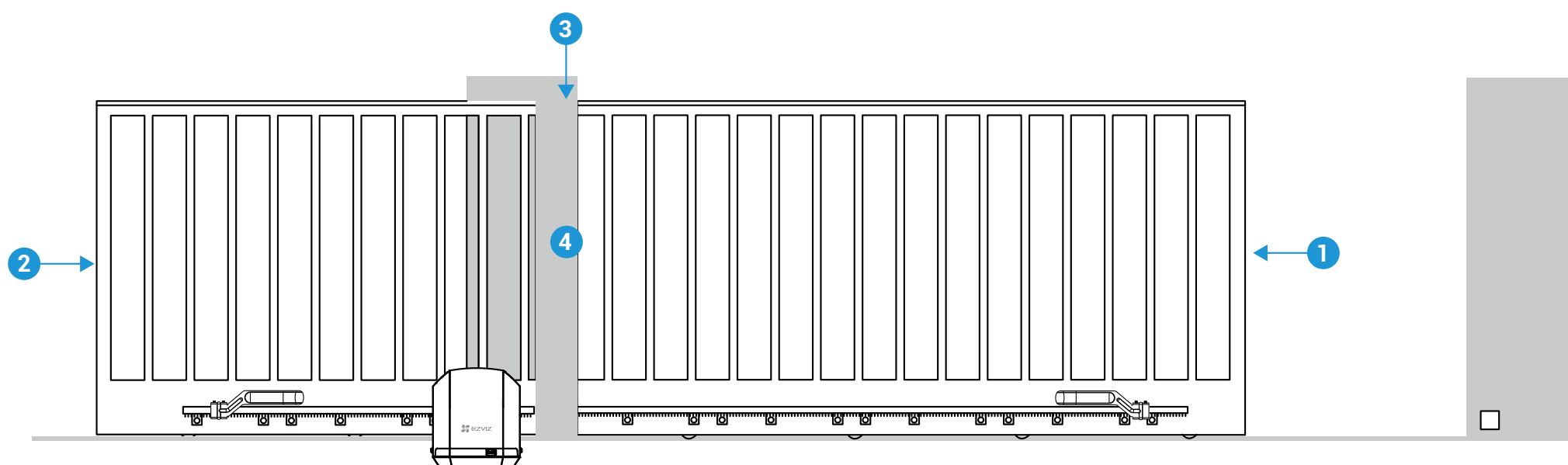

1: At the primary edge

Risk of shock and crushing
Solution: force limiter and photocellules (depends on type of use); set a low gate speed and a high resistance rebound sensitivity level; force limiters

2: At the secondary edge

Risk of shock, crushing and entrapment
Solution: photocellules, mesh and safety distance; set a low gate speed and a high resistance rebound sensitivity level; force limiters

3: At the upper slide

Risk of hand entrapment
Solution: safety distance and protection

4: Between the bars of an openwork gate and the pillar

Risk of shearing
Solution: mesh, net or force limiter

2. Risk Elimination

2.1 At the Primary Edge

There is a risk of crushing between the primary edge of the gate and the pillar when it closes. In order to reduce this risk, the gate opener provides the resistance rebound protection function. If the gate opener must force more than what it is authorized to do (by adjusting a sensitivity threshold to the effort), the gate opener stops itself and releases the pressure against the obstacle (person or vehicle).

It is also recommended to install the photocellules provided to detect the passage of a person or vehicle during gate closing. Cutting the photocellule beam should cause the gate to stop immediately.

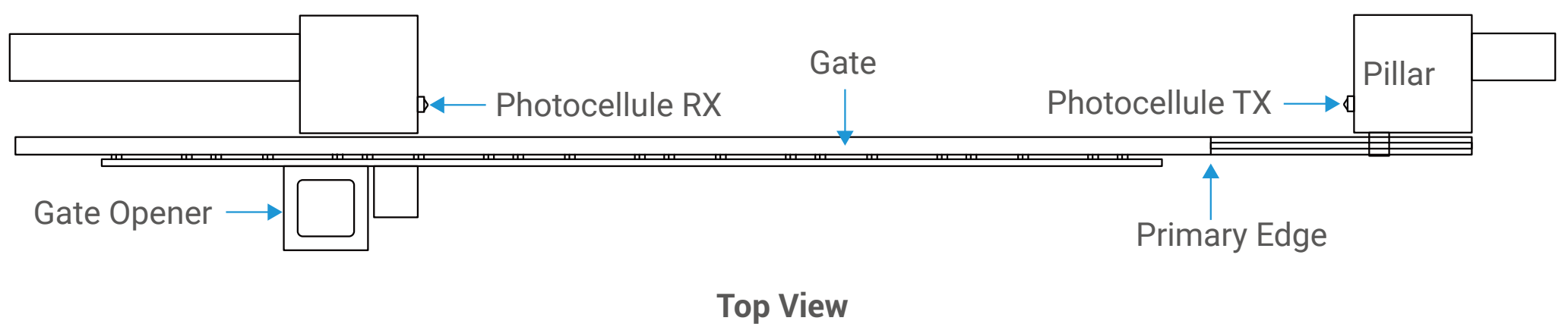

You can also install a force limiter at the primary edge for protection.

2.2 At the Secondary Edge

Depending on your installation, there may be risks of impact or crushing in the gate clearance area. In this case, you must eliminate these risks, for example by fencing the clearance area or by installing a force limiter.

- Example with a 1.5m fence

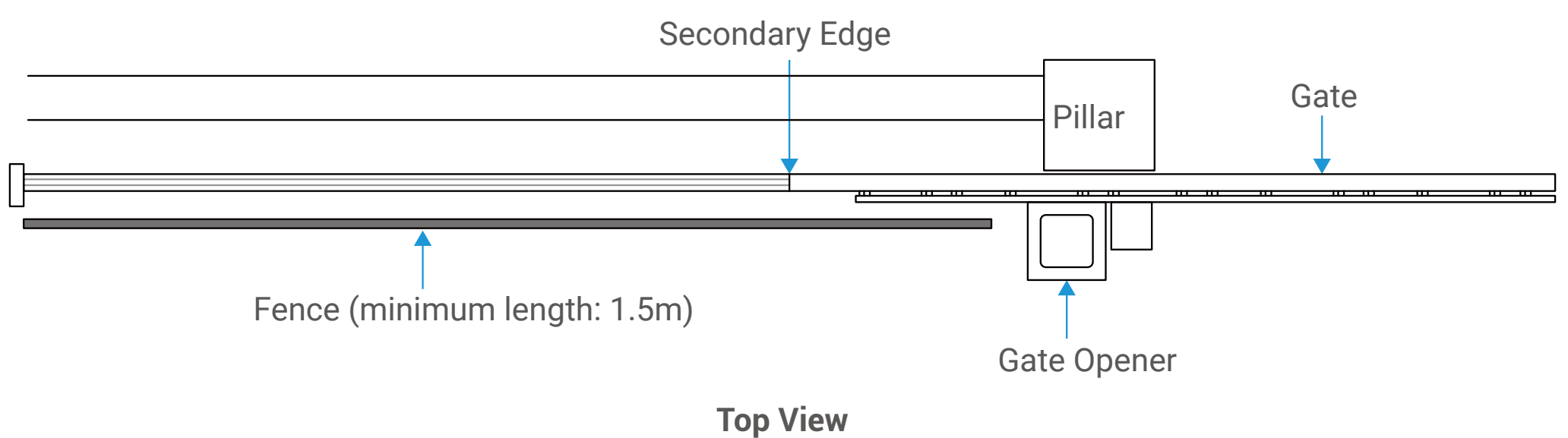

2.3 At the Upper Slide

There is a risk of hands being entrapped between the rollers of the upper slide and the gate. To avoid this risk, it is recommended to respect the safety distances given in the diagram below.

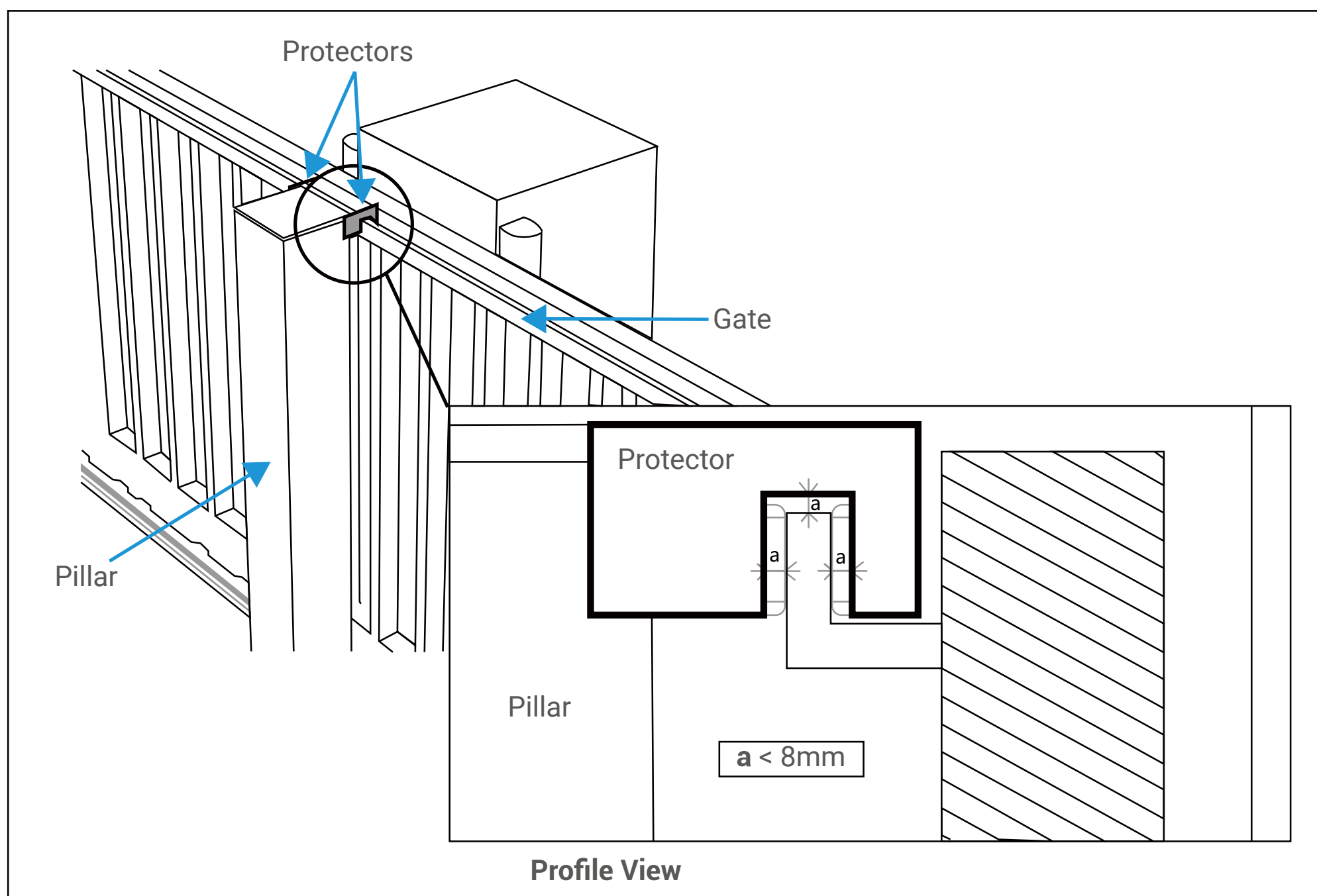

2.4 Between the Bars of an Openwork Gate and the Pillar

If the gate is an openwork gate, there is a risk of shearing between the bars of the gate and the pillar when the gate is moving. Two solutions to eliminate this risk:

- Install a fence or net on the gate. The mesh must be as fine as possible to avoid passing your fingers through it.
- Install one or two force limiters on each pillar.

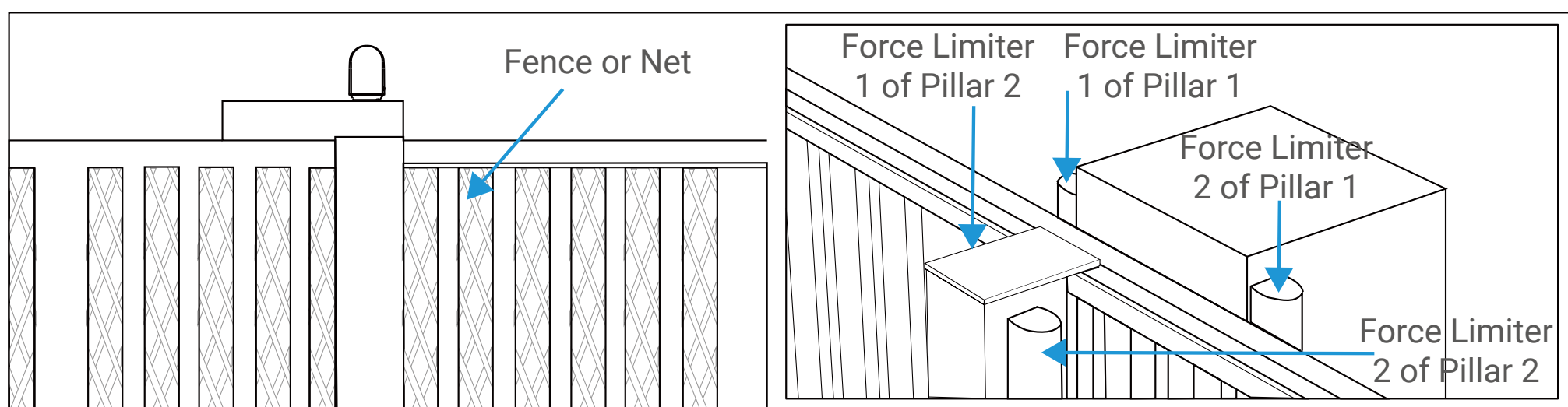

2.5 Clearance Area

In order to eliminate any risk of entrapment in the gate clearance area, it is recommended to respect the safety distances given in the diagram below.

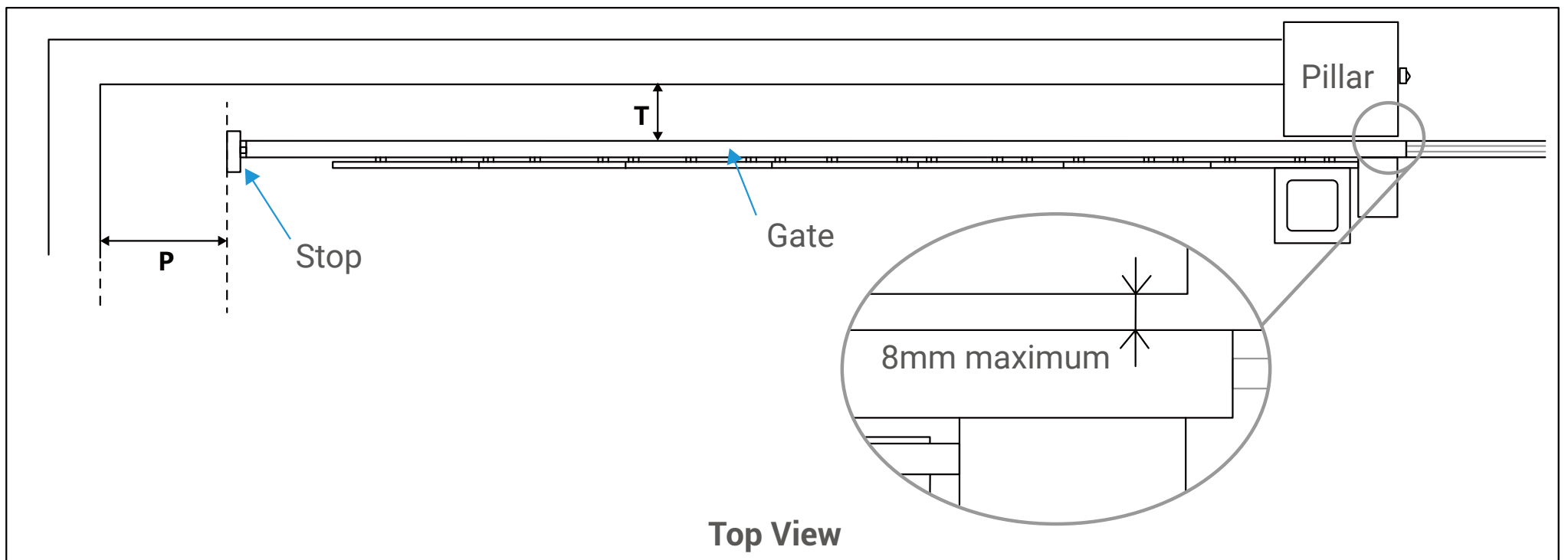





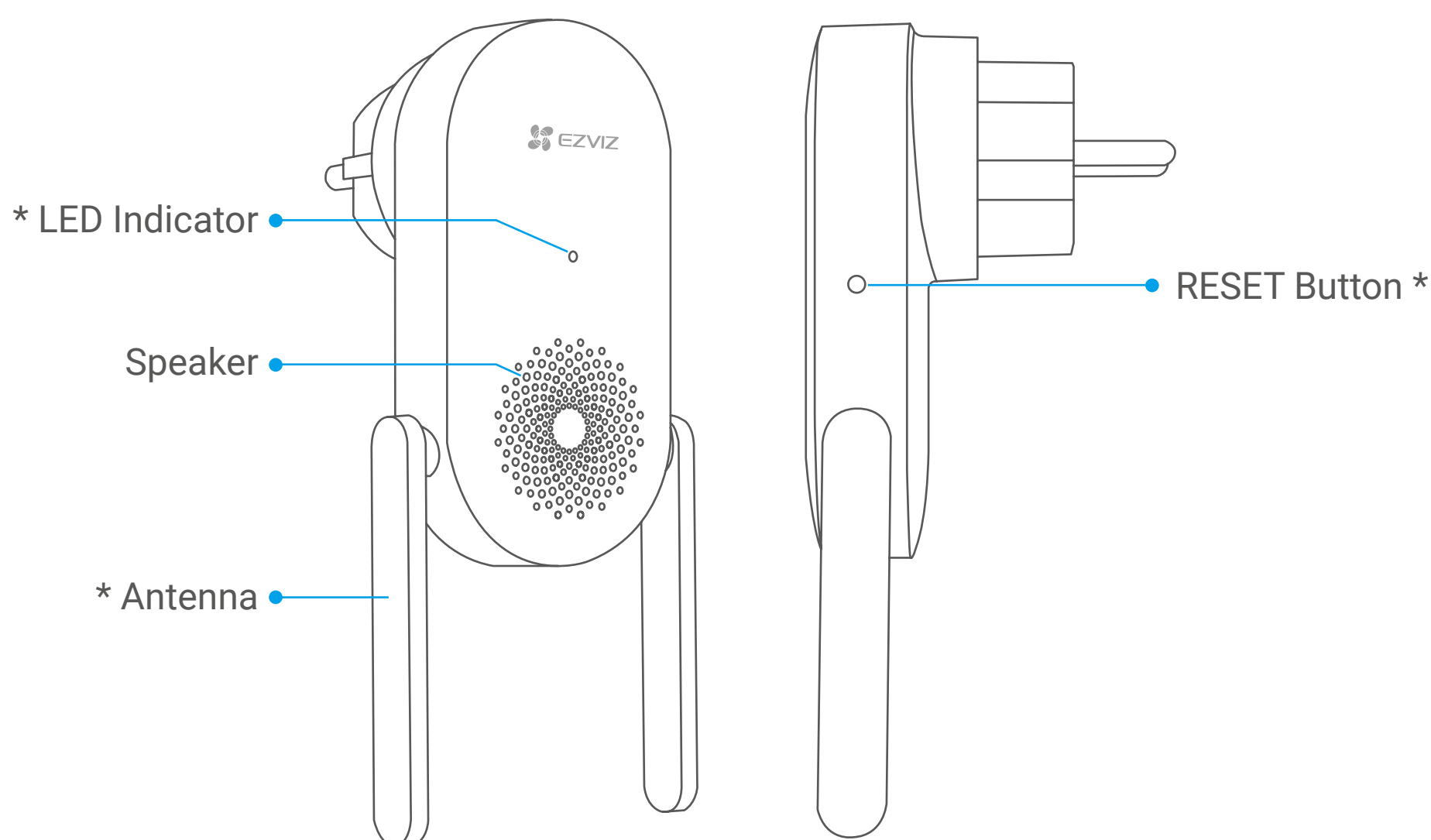

- If the distance T is less than 100 mm, the distance P must be greater than 200 mm
- If the distance T is greater than 100 mm, the distance P must be greater than 500 mm.

Install the Wireless Repeater

1. Basics



| Name | Description |
|---------------|---|
| Antenna | Enhances the transmission of the wireless network signals between the wireless repeater and the gate opener. |
| LED Indicator |  Solid red: Wireless repeater is starting up. |
| |  Slow-flashing red: Wi-Fi connection has failed. |
| |  Fast-flashing red: The Wireless Repeater's connection to the gate opener is broken. |
| |  Solid blue: Wireless repeater is functioning properly. |
| RESET Button |  Fast-flashing blue: Wireless repeater is ready for Wi-Fi connection. |
| | <p>Reset the wireless repeater:</p> <p> This operation is necessary when you need to change the wireless repeater's network, such as after relocating the gate opener.</p> <p>Press and hold this button for at least 3 seconds (but less than 10 seconds) until you hear a beep sound, then release the button. The LED indicator will become solid red, which indicates that the wireless repeater has been restarted and all parameters have been reset to defaults.</p> |
| | <p>Re-bind the wireless repeater:</p> <p> This operation is only necessary when setting up a newly purchased wireless repeater after your original one becomes unusable.</p> <p>Press and hold this button for 10 seconds until the LED indicator becomes fast-flashing red and blue alternately, which indicates that the wireless repeater is now ready for re-binding.</p> |
| Power Input | 100 to 240 VAC, 50/60Hz |
| | <p>Quick mute:</p> <p>Press the button once to mute the wireless repeater.</p> |

2. Get the EZVIZ App

1. Connect your mobile phone to Wi-Fi (suggested).
2. Download and install the EZVIZ app by searching for "EZVIZ" in the App Store or Google Play™.
3. Launch the app and register an EZVIZ account.

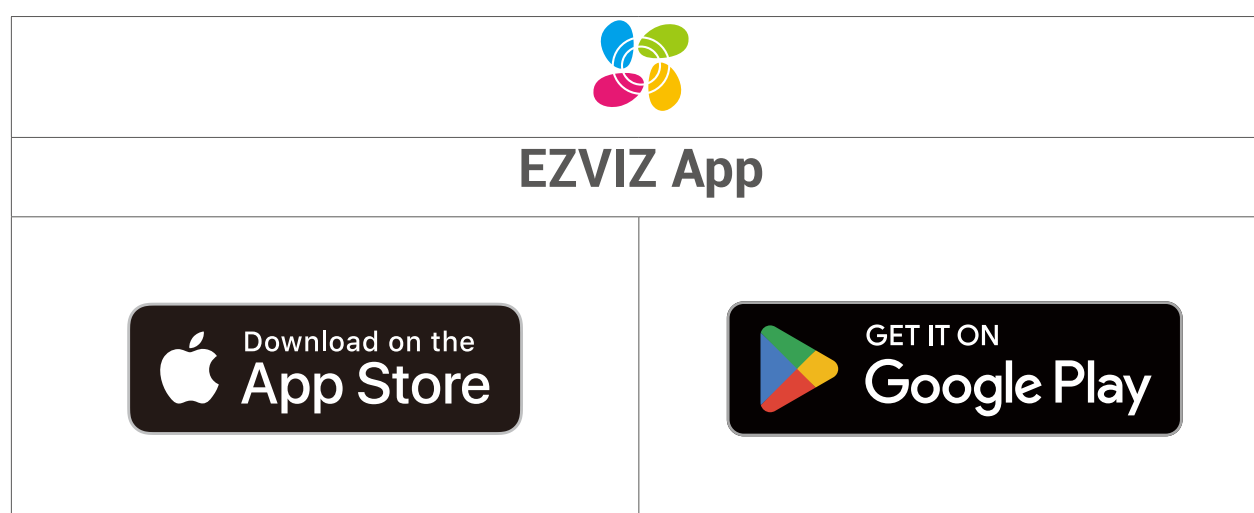

i If you have already used the app, please make sure that it is the latest version. To find out if an update is available, go to the app store and search for "EZVIZ".

3. Choose an Installation Location

Choose an installation location with a good wireless signal to wireless repeater. Please keep the following tips in mind:

- Install the wireless repeater as close to the gate opener as possible, with as few walls in between as possible.
- The antennas of the wireless repeater should be pulled up.
- Make sure that there are no metal obstructions nearby.

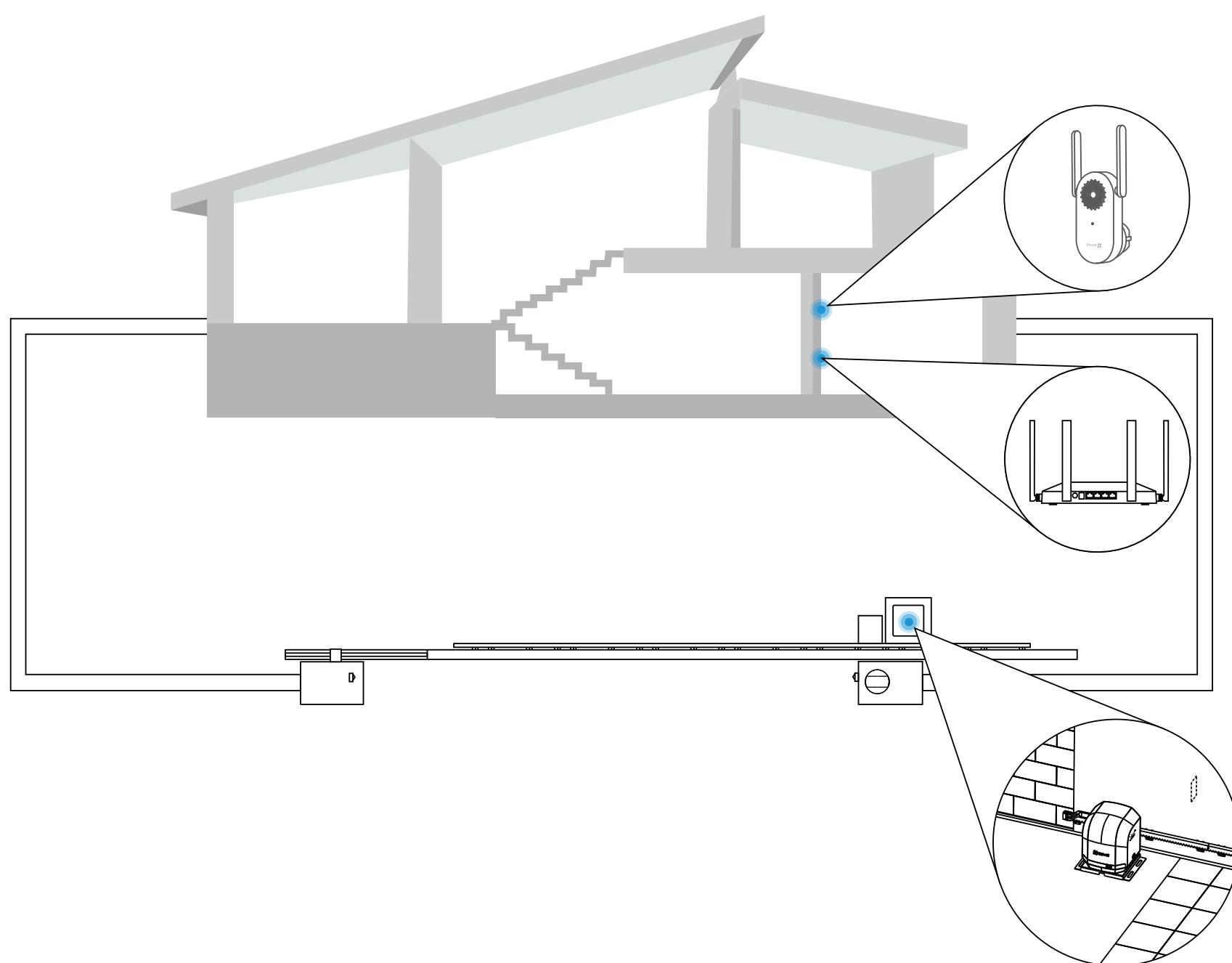

Wireless Communication Topology

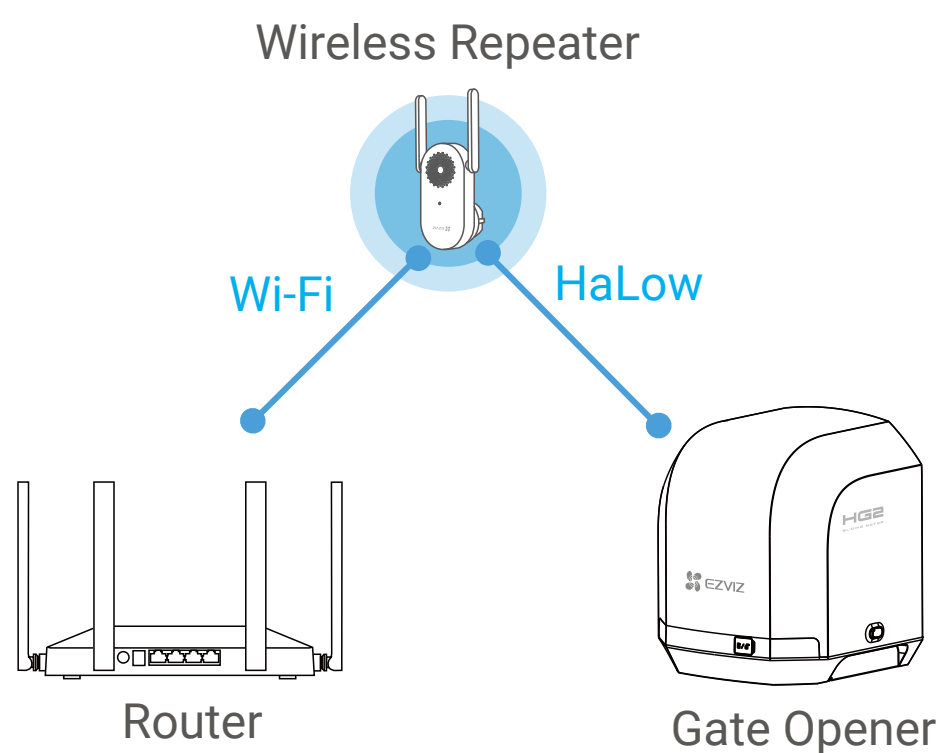

i Data communication between the wireless repeater and the gate opener is based on private protocols, independent of your Wi-Fi network.

Transmission Performance of Wireless Repeater

| Environment | Distance * |
|-------------------------|------------|
| In open environment | 300 meters |
| With 1 wall in between | 110 meters |
| With 2 walls in between | 75 meters |
| With 3 walls in between | 65 meters |

* The distance refers to the distance between the wireless repeater and the gate opener. The data is from EZVIZ Lab's test results under standard conditions.

4. Plug in Wireless Repeater

Plug the wireless repeater into a power outlet. When the LED indicator becomes fast-flashing blue, it indicates that the wireless repeater is ready for Wi-Fi connection.

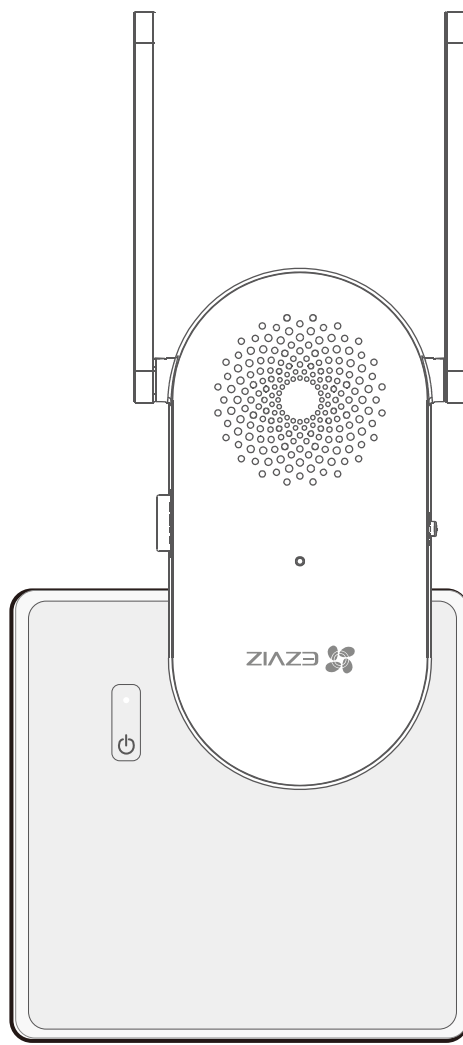

5. Add Wireless Repeater to Your EZVIZ Account

1. Log in to your EZVIZ account.
2. On the Home screen, tap "+" in the upper-right corner to go to the Scan QR Code interface.
3. Scan the QR code on the body of the wireless repeater.

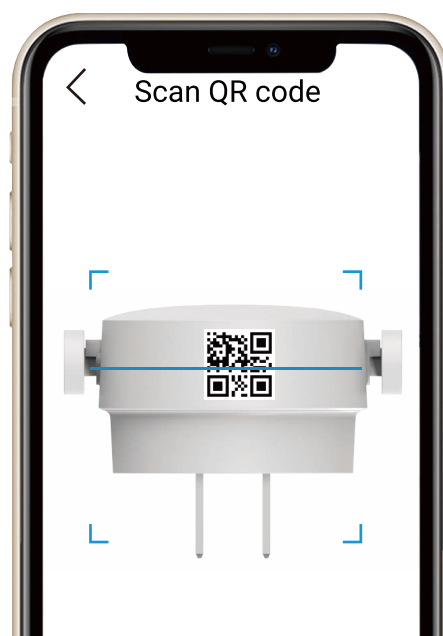

4. Follow the EZVIZ app wizard to finish Wi-Fi configuration and add the wireless repeater to your EZVIZ account.
5. After the wireless repeater is added, complete Terminal Authorization in the EZVIZ app.

i If terminal authorization is not completed, the gate opener and alarm light will not be added after power-on.

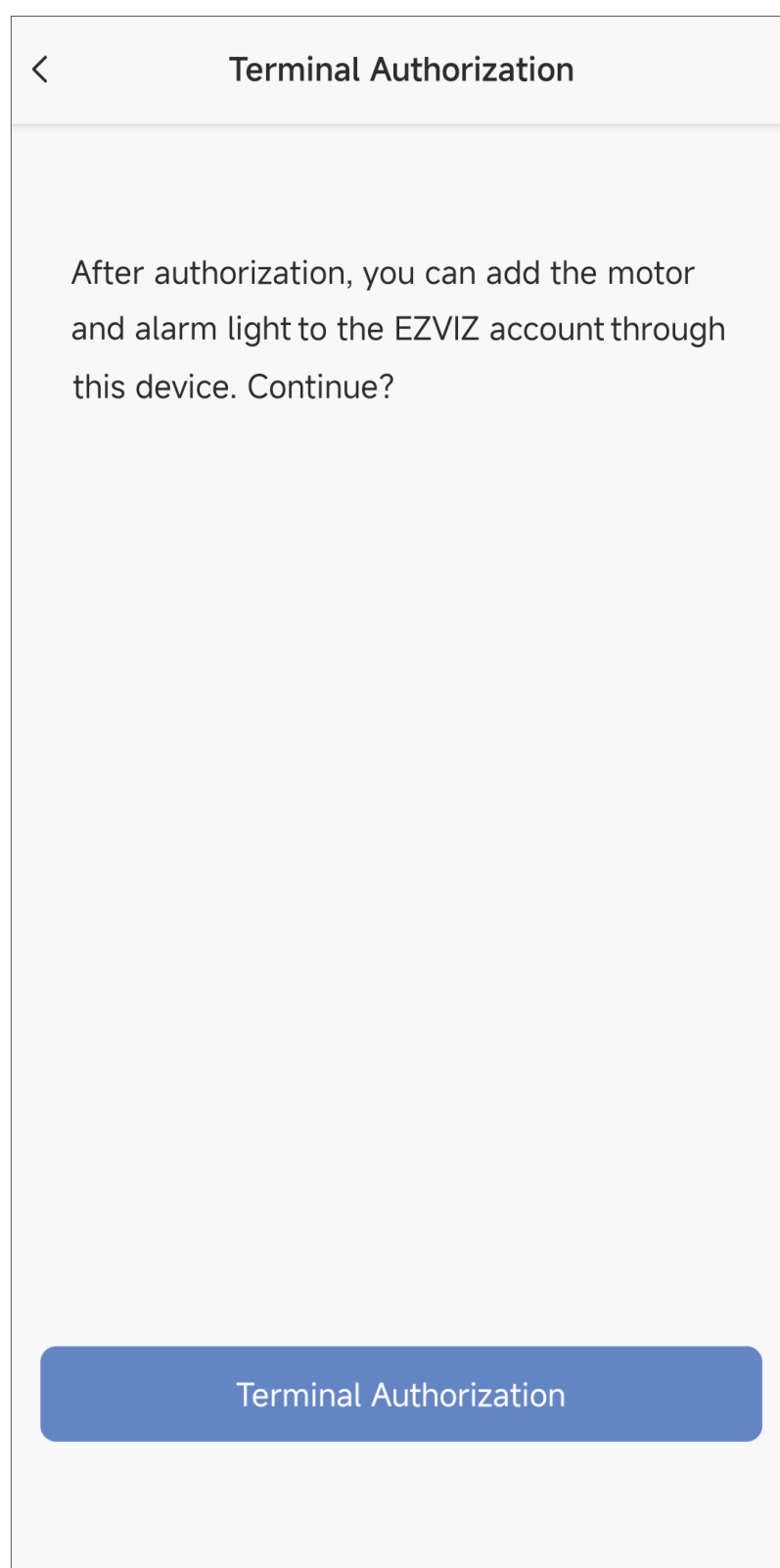

- Please connect your wireless repeater to the Wi-Fi network to which your mobile phone has been connected.
- If the wireless repeater fails to connect your Wi-Fi network, press and hold the RESET button for about 5s to restart the wireless repeater and repeat the steps above.
- If you want to connect the wireless repeater to another Wi-Fi network, go to Settings > Network Settings in the EZVIZ app to change the Wi-Fi network.

6. Add Gate Opener to Your EZVIZ Account

After completing terminal authorization, the QR Code Scanning page appears, reminding you to scan the code on the main motor.

1. Tap "Next".
2. Scan the QR code (with the "Device Information" title above) on the gate opener.

- DO NOT scan the QR code on the wireless repeater that you just scanned.
- DO NOT scan the installation videos QR code (with the "Installation Videos" title above the code).

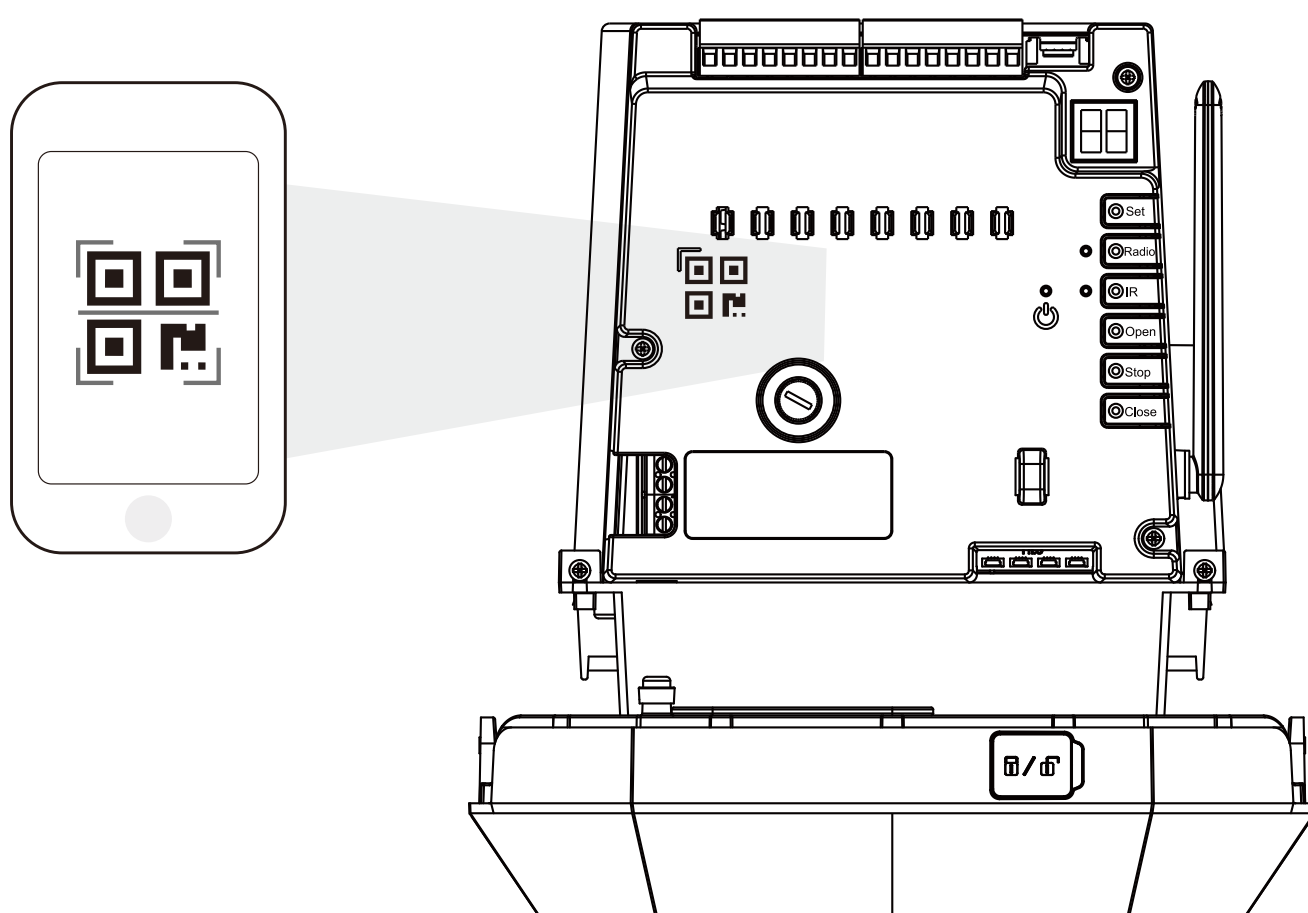

After successful code scanning, the installation wizard appears. You can follow the installation wizard to start installing the gate opener.

Install the Gate Opener

1. Basics

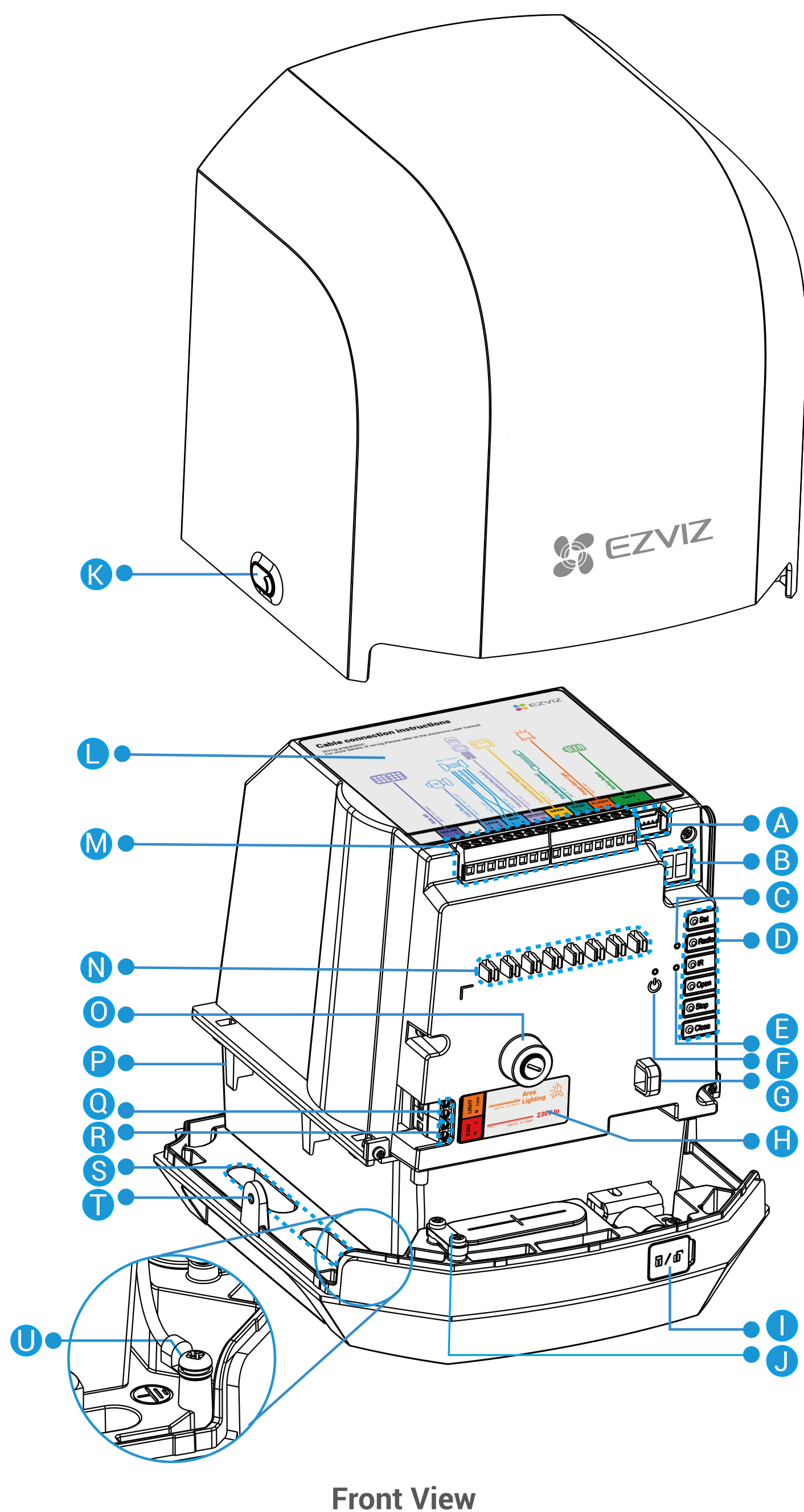

| Item | Description | Item | Description |
|------|--|------|---------------------------------------|
| A | Battery Terminal | L | "Cable Connection Instructions" Label |
| B | Digital Display Tube | M | Terminal Blocks |
| C | Radio Indicator | N | Cable Clamps |
| D | Control Buttons * | O | Fuse Holder * |
| E | IR Indicator | P | Notch |
| F | Power Indicator | Q | Area Lighting Interfaces |
| G | Cable Holder | R | Power Supply Interfaces |
| H | Power Connection Label | S | Inner Oblong Holes |
| I | Keyhole Cover | T | Outer Oblong Holes |
| J | Cable Entry | U | Earthing Rod and Cable |
| K | Screw Hole (below the waterproof plug) | | |

* Fuse specifications: $\Phi 5 \times 20 \text{mm}$ 250VAC 2A

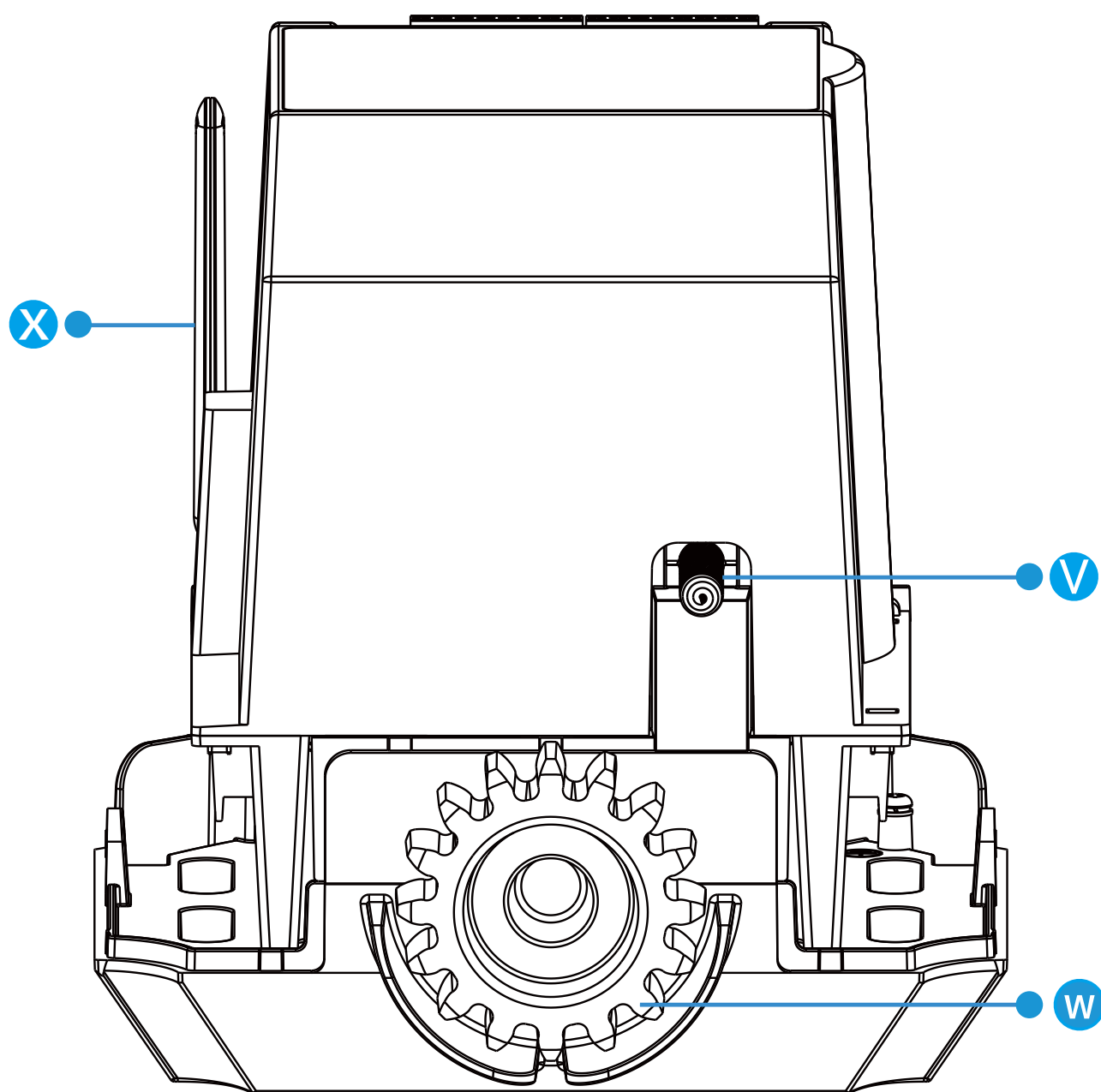

Rear View





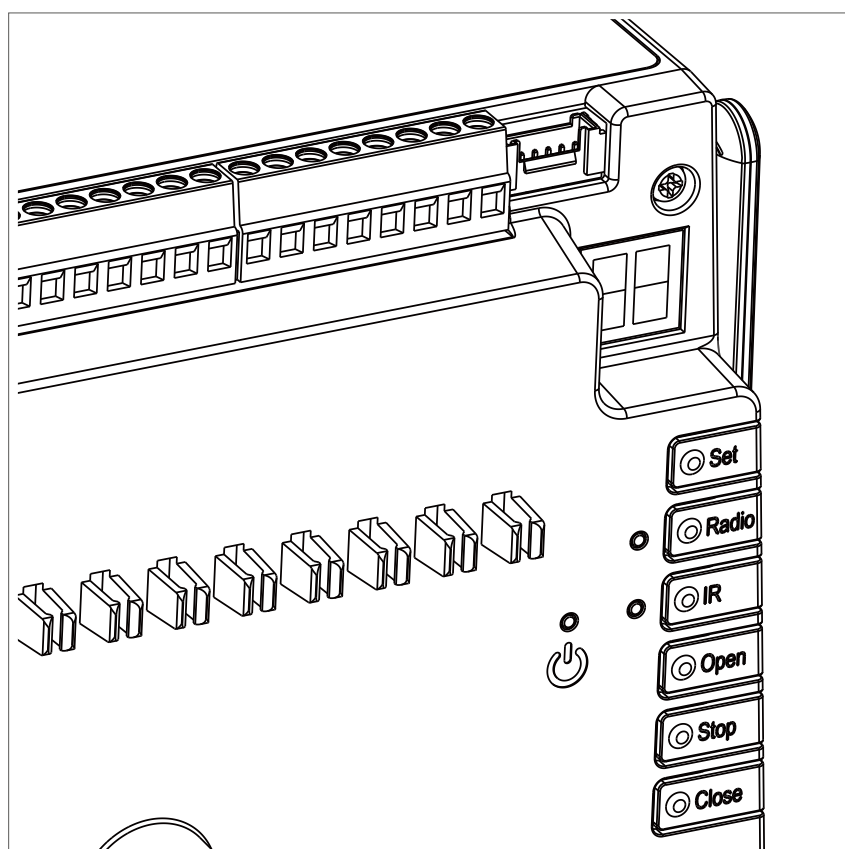



| Item | Description |
|------|--------------|
| V | Limit Spring |
| W | Gear |
| X | Antenna |

Presentation of the Control Buttons



| Name | Description | | |
|--------------|------------------------------|--|----------------------------|
| Set Button | Press and hold for 3 seconds | Enter or exit the main menu. | |
| | Press once | In the submenu mode, press once to exit the submenu and go back to the main menu. | |
| | Press and hold for 8 seconds | Restore the gate opener to factory settings. | |
| Radio Button | Press once | Enter the remote controller pairing mode. | |
| | Press and hold for 5 seconds | Clear all information about paired remote controllers. | |
| IR Button | Press once | Enter or exit the infrared self-testing mode. | |
| | Press and hold for 5 seconds | Start binding to a wireless repeater. i This operation is only necessary when setting up a newly purchased wireless repeater after your original one becomes unusable. | |
| Open Button | Press once | In normal working mode | Open the gate. |
| | | In menu mode | Switch to the next option. |

| Name | Description | | |
|--------------|------------------------------|--------------------------------|--------------------------------|
| Stop Button | Press once | In normal working mode | Stop the gate. |
| | | In menu mode | Confirm the current option. |
| | Press and hold for 5 seconds | Clear the current gate travel. | |
| Close Button | Press once | In normal working mode | Close the gate. |
| | | In menu mode | Switch to the previous option. |

| LED Indicator | Description | |
|-----------------|---|--|
| Radio Indicator |  | Solid red: The gate opener is now in remote controller pairing mode. |
| |  | Off: Exit pairing mode. |
| |  | Slow-flashing red (for 3 seconds): Remote controller paired successfully or the number of paired remote controllers has reached 8. |
| |  | Fast-flashing red (for 3 seconds): All remote controllers are cleared. |
| IR Indicator | In normal working mode: | |
| |  | Off: No obstacles are detected. |
| |  | Solid red: Obstacles are detected. |
| | In infrared self-testing mode: | |
| |  | Solid red: No obstacles are detected. |
| Power Indicator |  | Solid red: The gate opener is powered by an AC 220-240V power supply or a DC 24V solar kit. |
| |  | Off: The gate opener is powered by the backup battery. |

2. Remove the Gate Opener Cover

1. Open the waterproof plugs on both sides of the gate opener cover.
2. Use a screwdriver to remove the screws below the waterproof plugs.
3. Remove the cover by lifting it up.

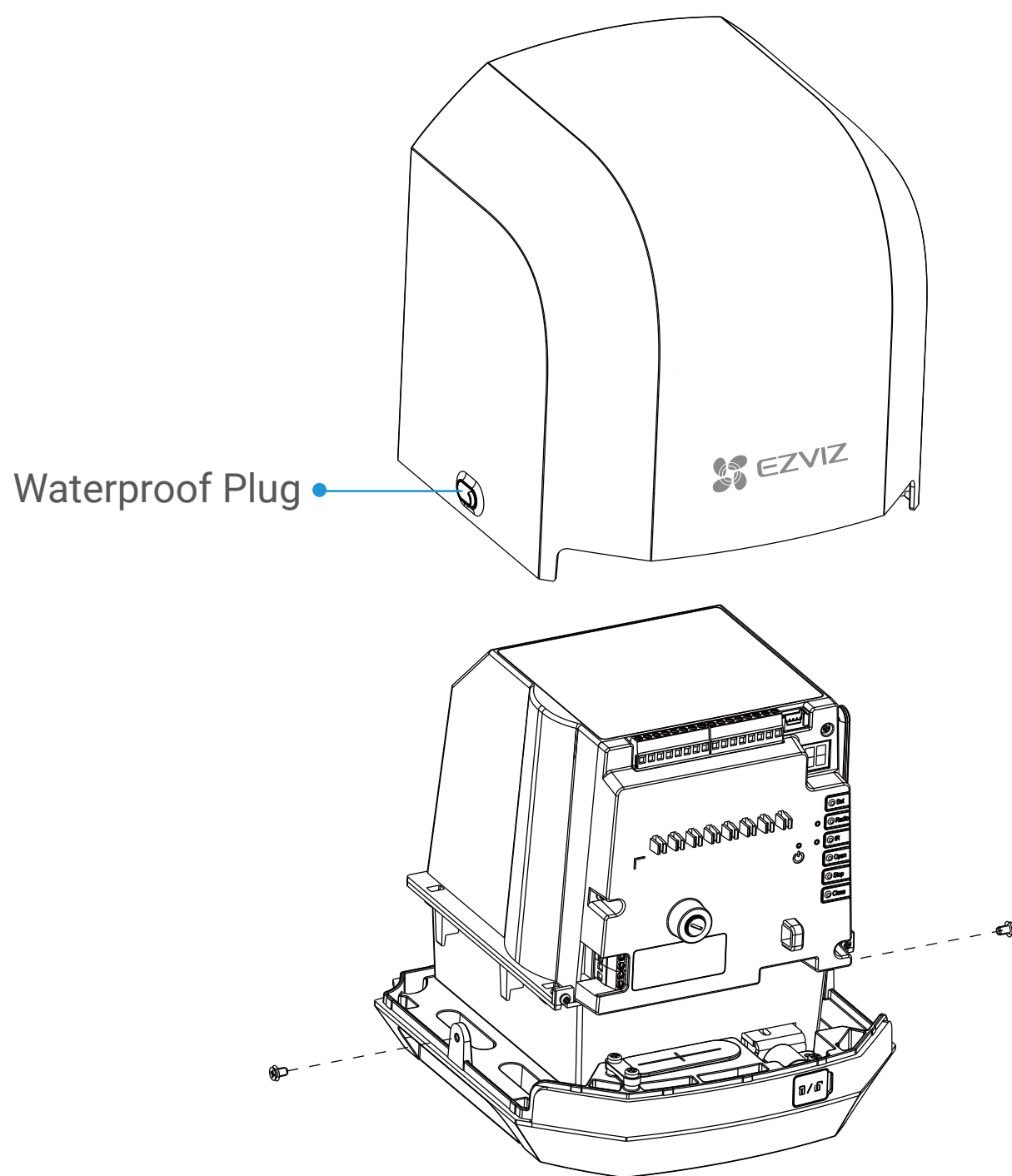

i Please keep the removed screws safe.

3. Fix the Gate Opener to the Ground

- i** • The gate opener should be installed on the side of the gate frame to which the gate opens:
 If the gate opens to the left, the gate opener should be installed on the left side (left installation mode).
 If the gate opens to the right, the gate opener should be installed on the right side (right installation mode).
- The installation mode can be set in the EZVIZ app.
- The diagrams in this user manual illustrate the left installation mode as an example.

Important notes about height check and adjustment:

Before fixing the gate opener to the ground, check the height of your gate brace or existing gear racks (if any) to determine the required shimming height. This will help you decide whether to use the shim (for a smaller shimming height) or the mounting base (for a larger shimming height). Both are included in the package.

If the shimming height provided by the mounting base is not enough, you can adopt the following methods for adjustment:

Use flat washers

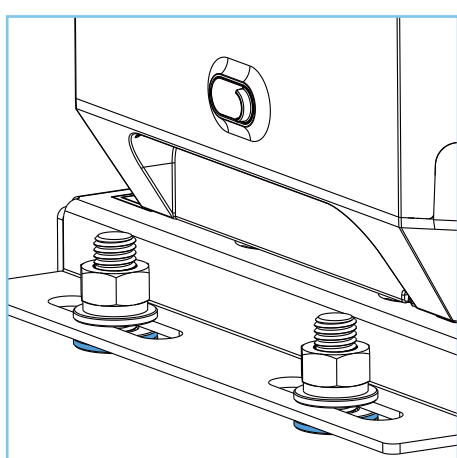

Use nuts

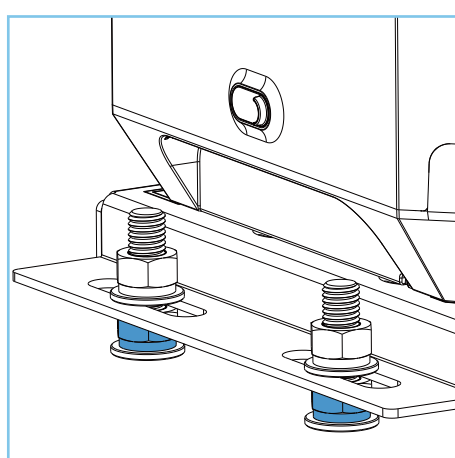

Use expansion screw and nuts

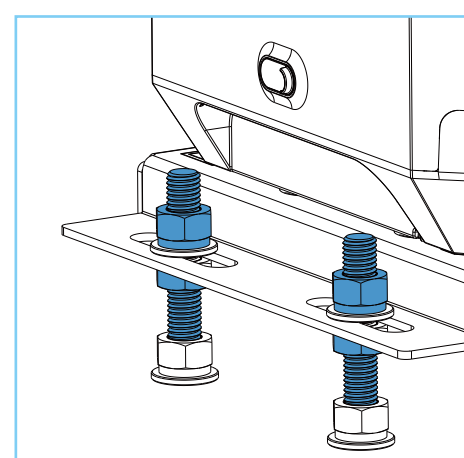

- If it is convenient, you can adjust the height of your existing gear racks.
- If the shimming height obtained through the above methods is still not enough, consider building a concrete block.

Step 1: Mark anchoring points and drill holes.

1. Place the mounting base parallel to the gate (ensuring a 60 mm distance between the mounting base and the gate).
2. Mark 4 anchoring points for the mounting base on the ground.

- It is recommended to check whether there are existing holes on the ground that can be directly used. If so, you can skip the drilling step.
- The anchoring points should be at the center of the oblong holes on the mounting base, so that it will be convenient to adjust the position of the gate opener.

3. Remove the mounting base.

4. Use a drill bit (diameter 14) to drill 4 holes (drilling depth: 65-70mm) in the concrete.

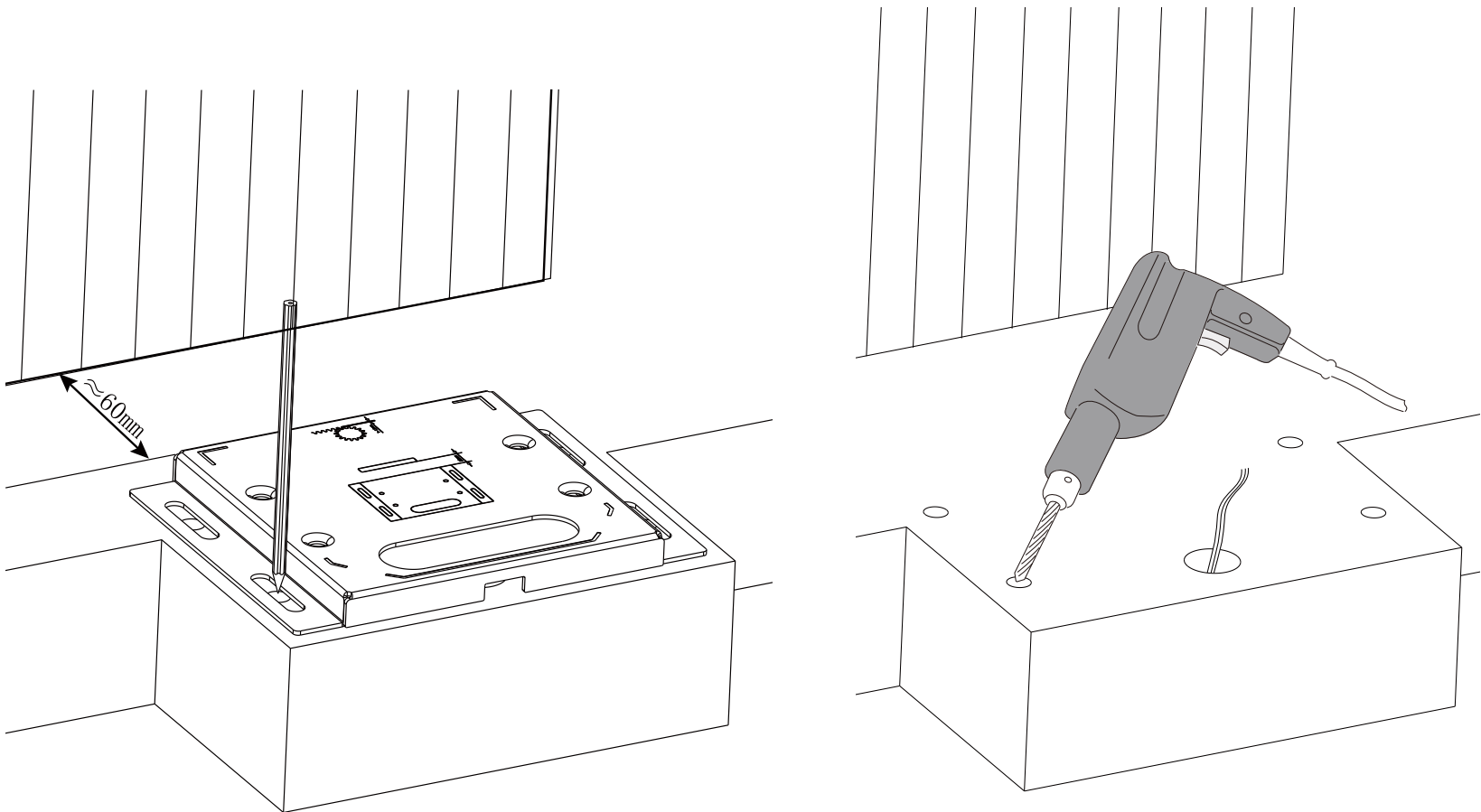

- When drilling a hole, make sure that the drill bit remains vertical, in case the diameter of the hole is too large.

Step 2: Fix the gate opener to the mounting base.

1. Place the gate opener upside down.

2. Align the mounting base with the gate opener, as shown in the diagram below (left), ensuring that the edge of the mounting base is aligned with the gear motor.

- Make sure that the front of the gate opener is aligned with the mounting base edge where the cable entry is located.
- Make sure that the motor gear is parallel to the edge of the mounting base.

3. Insert 4 hexagonal screws through the round holes on the mounting base into the oblong holes on the gate opener.

4. Lay the gate opener and the mounting base down on its right side.

5. Use two spanners to fix the nuts, washers, and screws on the left side, with one spanner for fixing the screw and the other for tightening the washers and nuts, as shown in the diagram below (right).

6. Lay the gate opener and the mounting base on the left side and fix the screws on the right side.

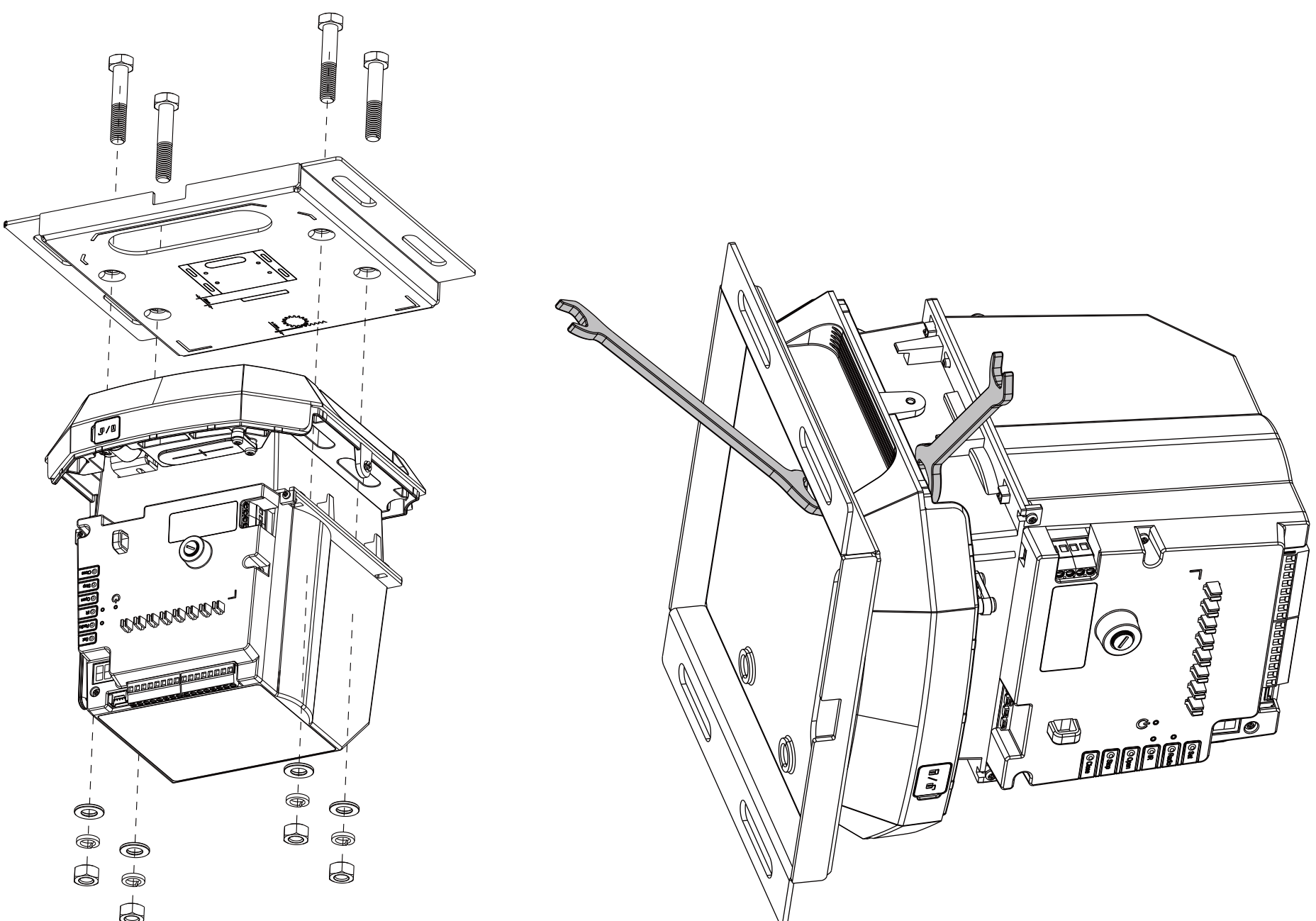

Step 3: Fix the mounting base to the ground.

1. Insert the 4 expansion screws supplied into the 4 holes, fix them in the ground, and then remove the nuts and washers, as shown in the diagram below (left).
2. Guide all necessary cables through the oblong holes on the mounting base and the gate opener, separately.
3. Position the mounting base so that the 4 expansion screws pass through the oblong holes of the mounting base.
4. Use washers and nuts to fix the expansion screws (do not tighten the screws yet).
5. Check that the gate opener is parallel to the gate at a distance of around 60mm. Then, use washers and nuts to tighten the screws.

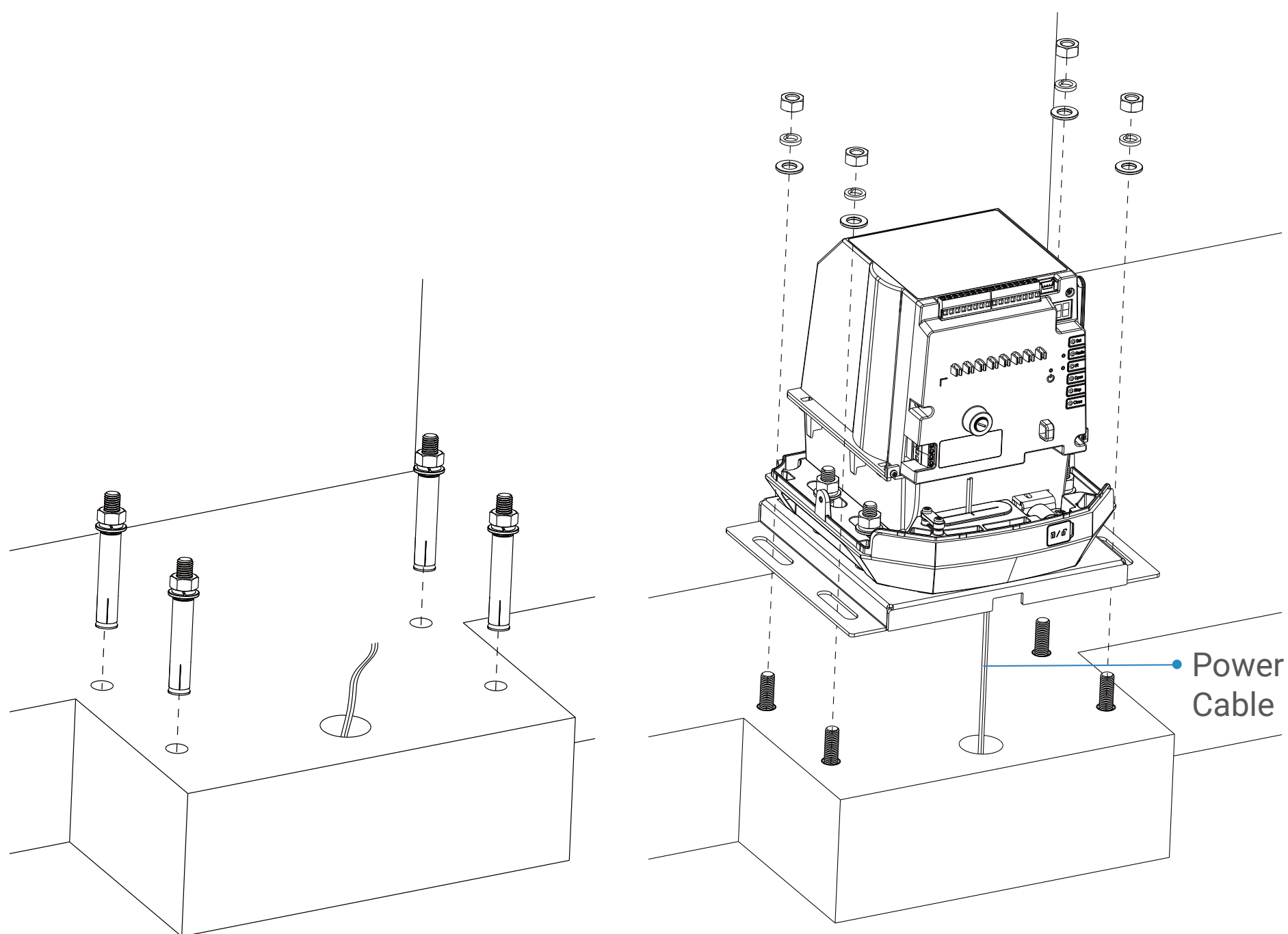

Step 4: Connect the power cable.

- ⚠ • The gate opener requires a power cable (with a plug) to connect to an external power supply, or must be connected to a dual power switch compliant with EN 60664-1.
- Be sure to open the circuit breaker to be used for the gate opener first.

1. Loosen the two screws (see A in the figure) and remove the cover plate (see B in the figure) of the cable entry on the gate opener.

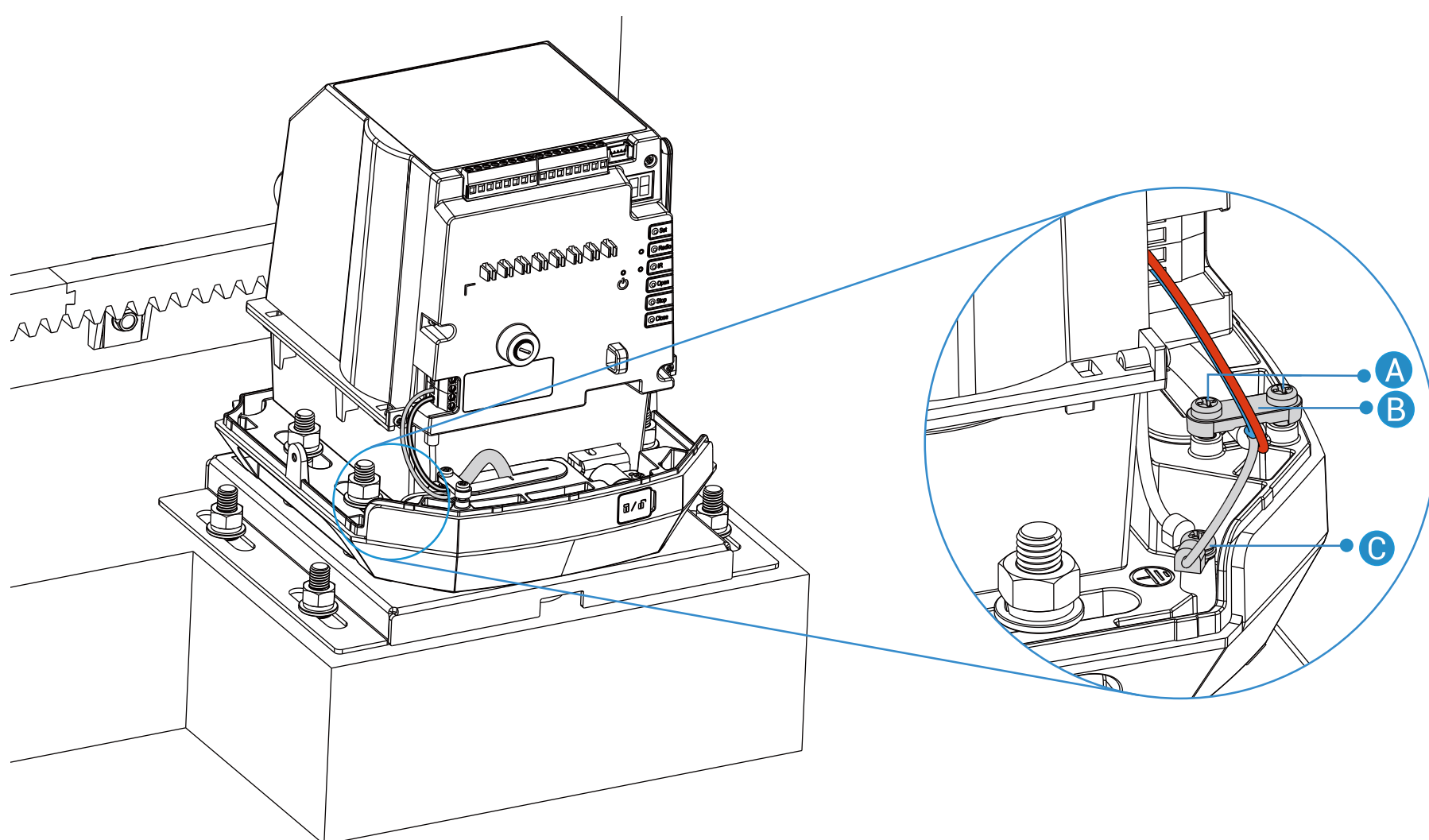

2. Connect the live wire (red wire in the figure) to the L interface and the neutral wire (blue wire in the figure) to the N interface (refer to the sticker on the gate opener, as shown below).

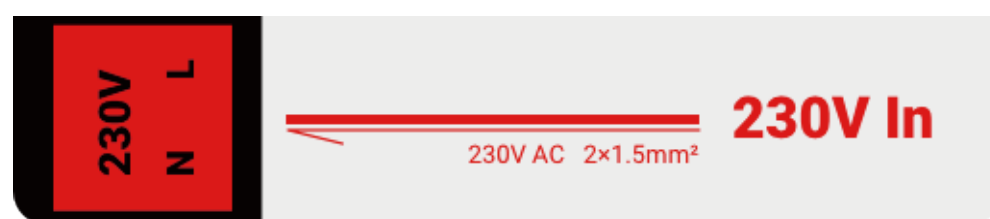

3. Connect the earth wire (grey wire in the figure) to the earthing rod.
 - a. Loosen the screw (see C in the figure) on the earthing rod.
 - b. Twist the earth wire with the existing earth wire together.
 - c. Tighten the screw back on the earthing rod.
4. Put the wires in the cable entry and use the screws to fix the cover plate back.

The steps above describe how to fix the gate opener using the mounting base as an example. If you choose to use the shim, refer to the diagrams below. Operation details are similar to those for using the mounting base for installation.

- 1 Use the gate opener and the shim to mark anchoring points.

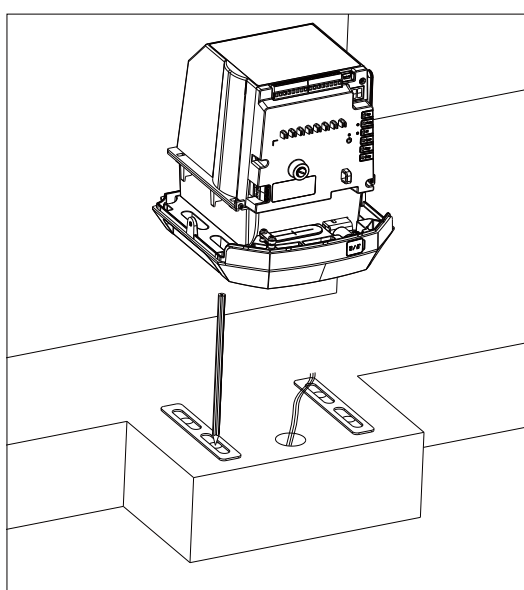

- 2 Drill holes.

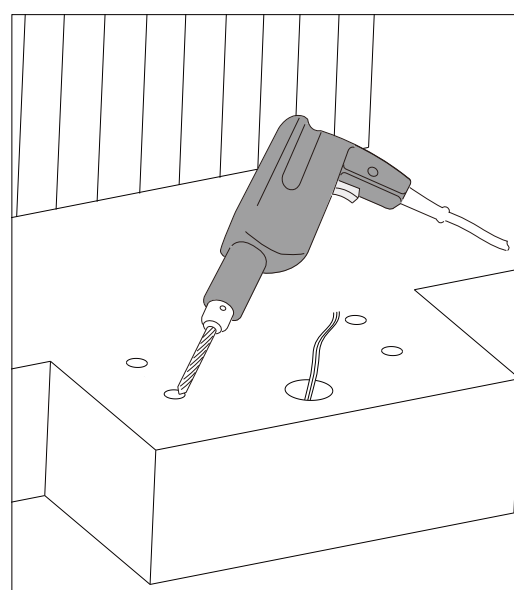

- 3 Insert expansion screws.

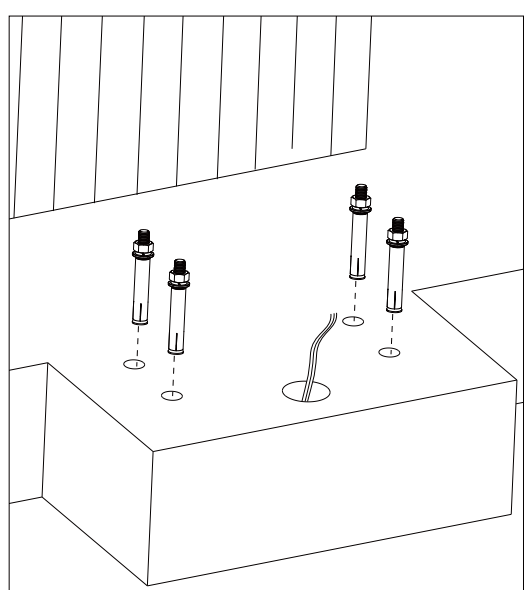

- 4 Fix the shim and the gate opener.

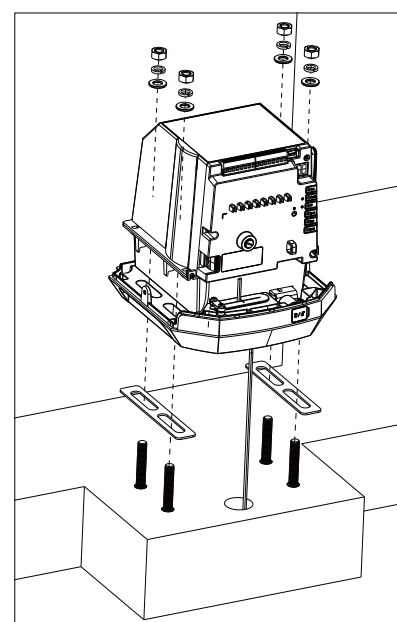

Install Gear Racks and Limit Sheet Metal

i If you already have M4 gear racks fixed on your gate brace, you can use the existing gear racks and do not need to install the gear racks in the package. However, be sure to leave a distance of 1 to 1.5 mm between the rack and the gear motor toothed wheel of this gate opener.

- !**
- The gear racks must be fixed to the gate brace.
 - Use screws suitable to the material of your gate. Use self-drilling screws (not included) for a metal gate and use self-tapping screws (not included) for a wooden gate.
 - Never lubricate the gear or the gear racks.

Required specifications and quantity of screws (not included) for each gear rack

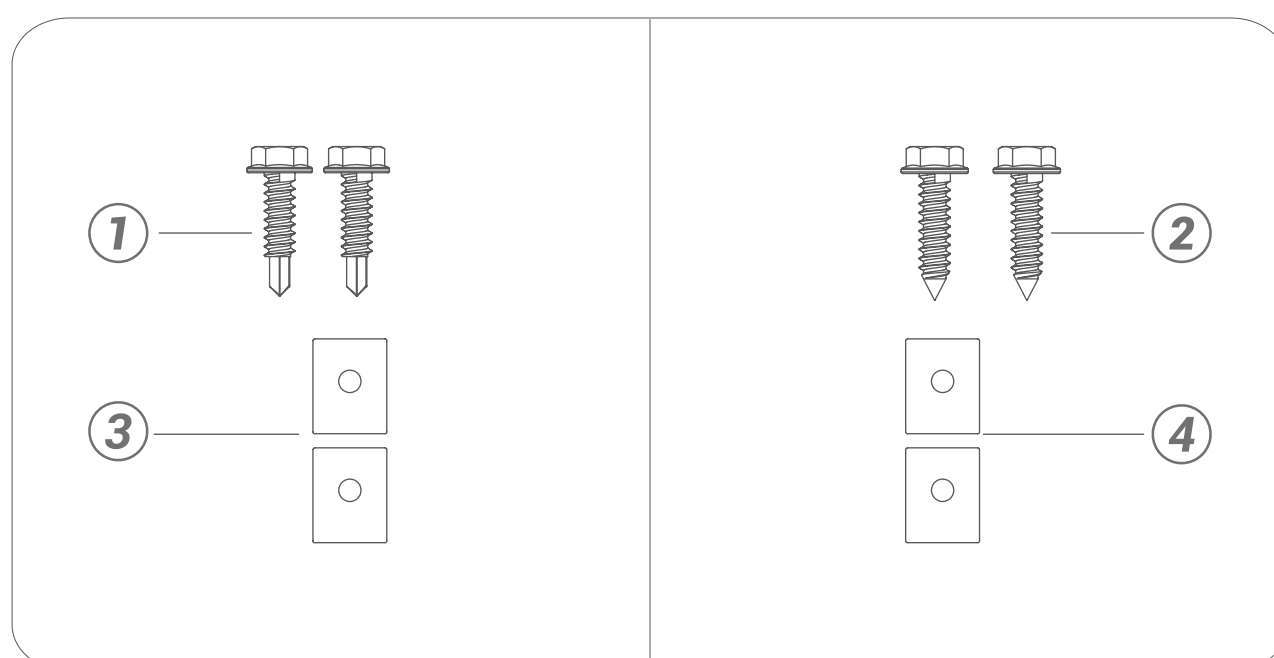

| No. | Material of Gate | Name | Quantity |
|------|------------------|----------------------------|------------|
| 1 | Metal | 6.3×25 Self-drilling Screw | 2 per pack |
| 2 | Wooden | 6.3×25 Self-tapping Screw | 2 per pack |
| 3, 4 | / | Gasket | 2 per pack |

1. Components Required

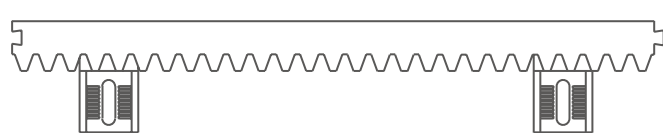

Gear Racks (0.33m×12)

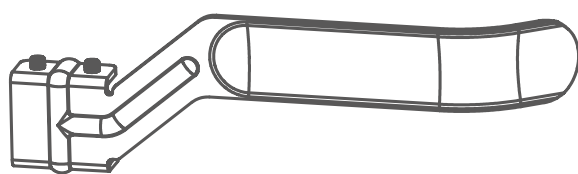

Left Limit Sheet Metal (×1)

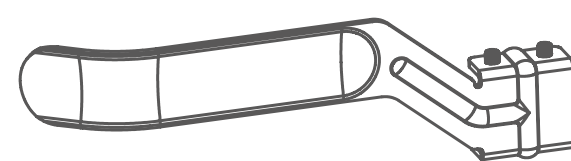

Right Limit Sheet Metal (×1)

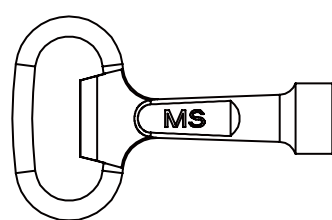

Key (×1)

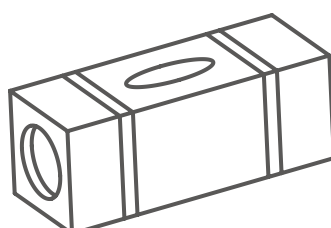

Mini Level (×1)

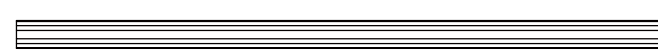

Pencil (×1)

2. Unlock the Gate Opener

1. Open the keyhole cover and insert the key supplied.
2. Rotate the key clockwise for 180 degrees.
3. Pull out the key and place the keyhole cover back.
4. After unlocking the gate opener, manually open and close the gate. If any obvious resistance can be felt, adjust the installation environment of the gate opener to remove the source of such resistance.

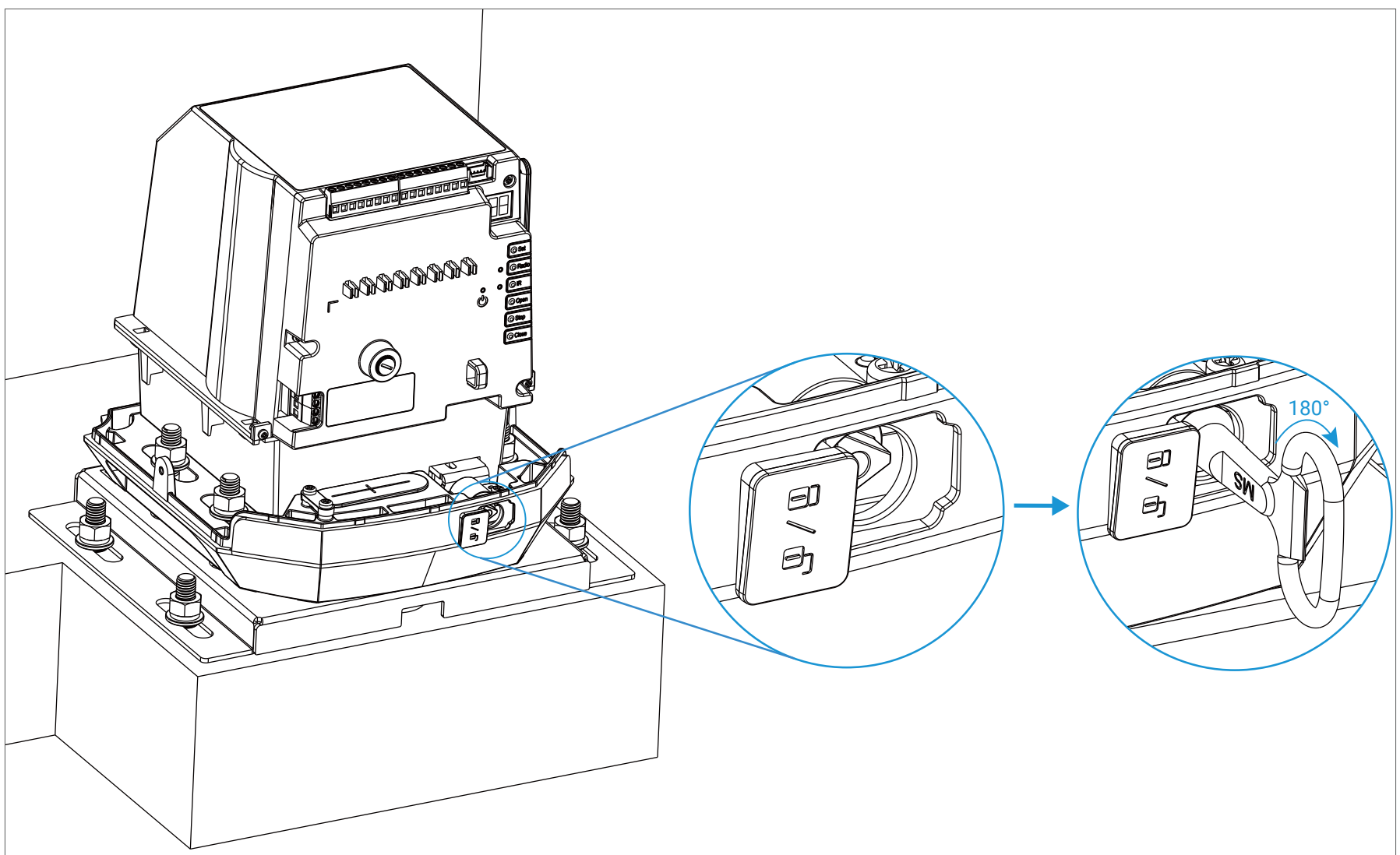

3. Fix the Gear Racks

1. Open the gate completely.
2. Position a pencil in the notches provided for this purpose (as shown by the arrow in the diagram below), making sure that the tip of the pencil lead is in contact with the gate brace. Then slide the gate from end to end to mark a line.

i While marking a line, hold the pencil to make sure that the pencil can draw a clear, solid, and straight line on the gate. Be careful not to break the pencil lead.

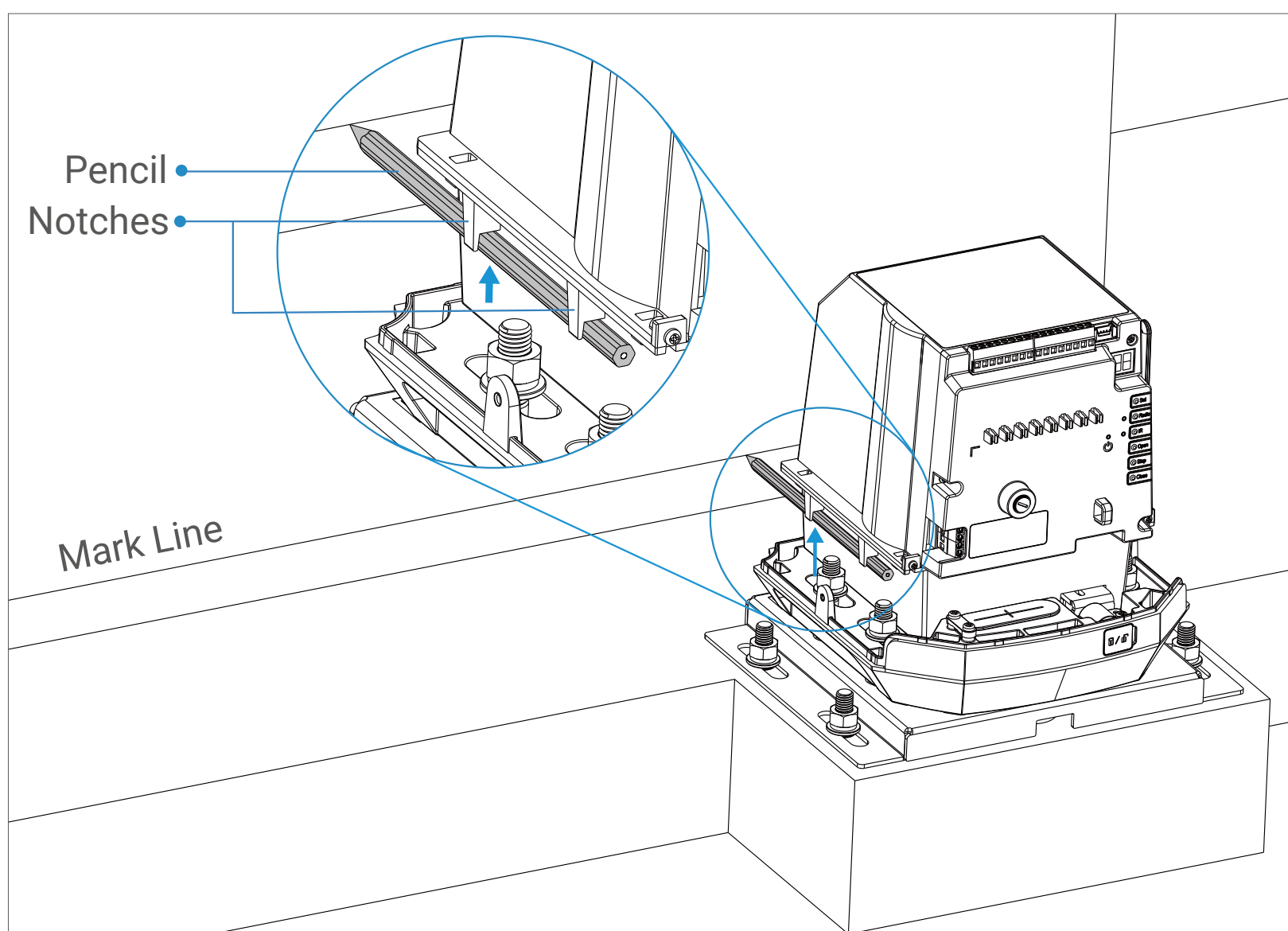

3. Position a first gear rack by aligning the center of the oblong holes with the mark line.

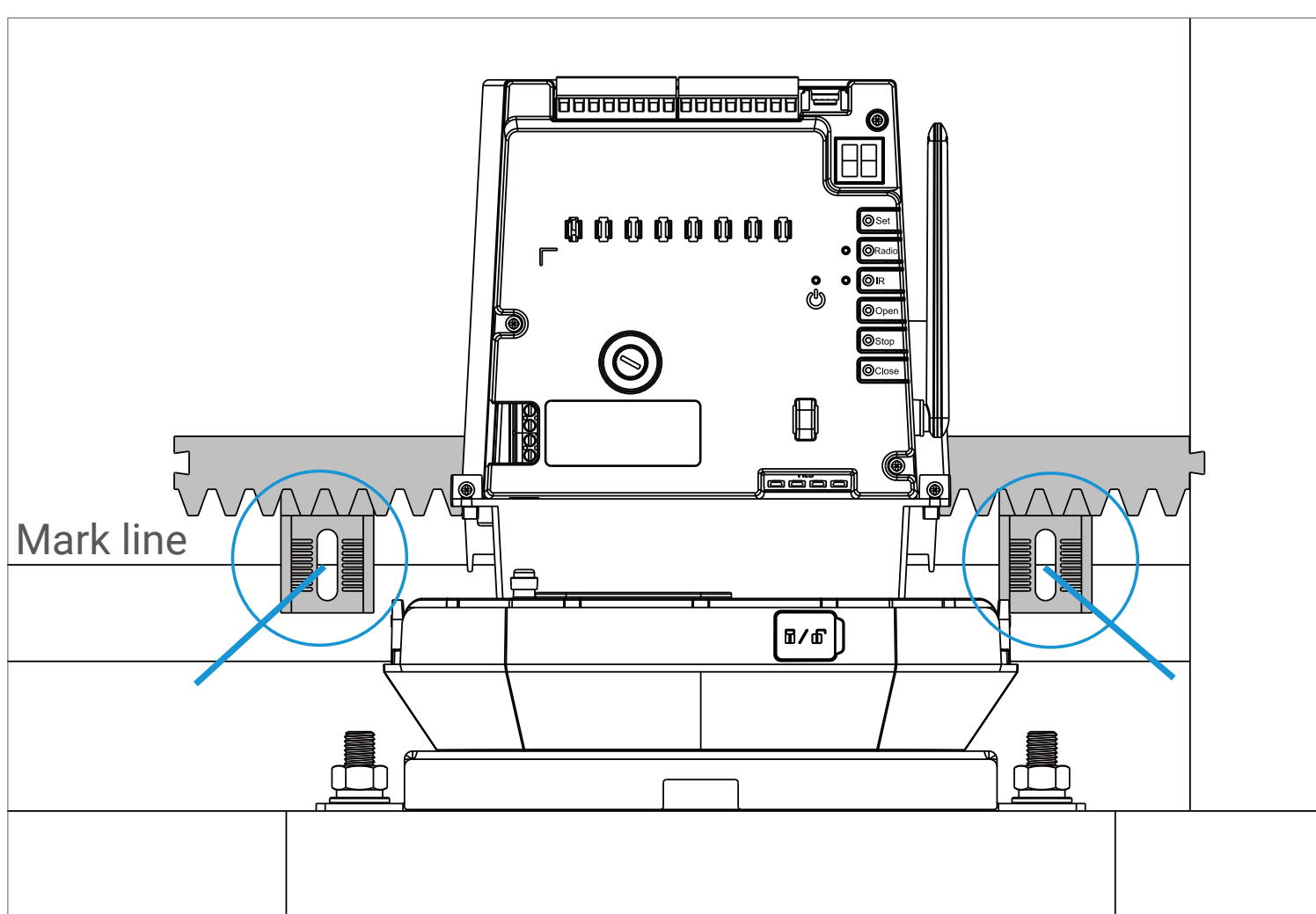

- i** Leave a distance of 1 to 1.5 mm between the rack and the gear motor toothed wheel. If the distance is too large after efforts, consider adding a padding plate (with holes on it for screws to pass through) between the gate opener and the mounting base.

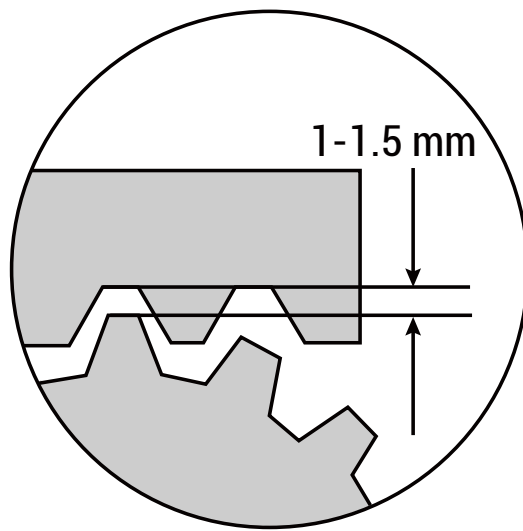

4. Use screws and washers to fix the gear rack at the center of the oblong holes (on the mark line), while using the mini level supplied to make sure that the gear rack is in horizontal position.

- i** • After drilling screws into the gate brace, do not fix the screws too tight. Check the distance between the rack and the gear motor toothed wheel again to make sure that it's still within the range of 1 to 1.5 mm.
- The diagram below illustrates using self-drilling screws to fix the gear rack onto a metal gate. If your gate is a wooden gate, use self-tapping screws.

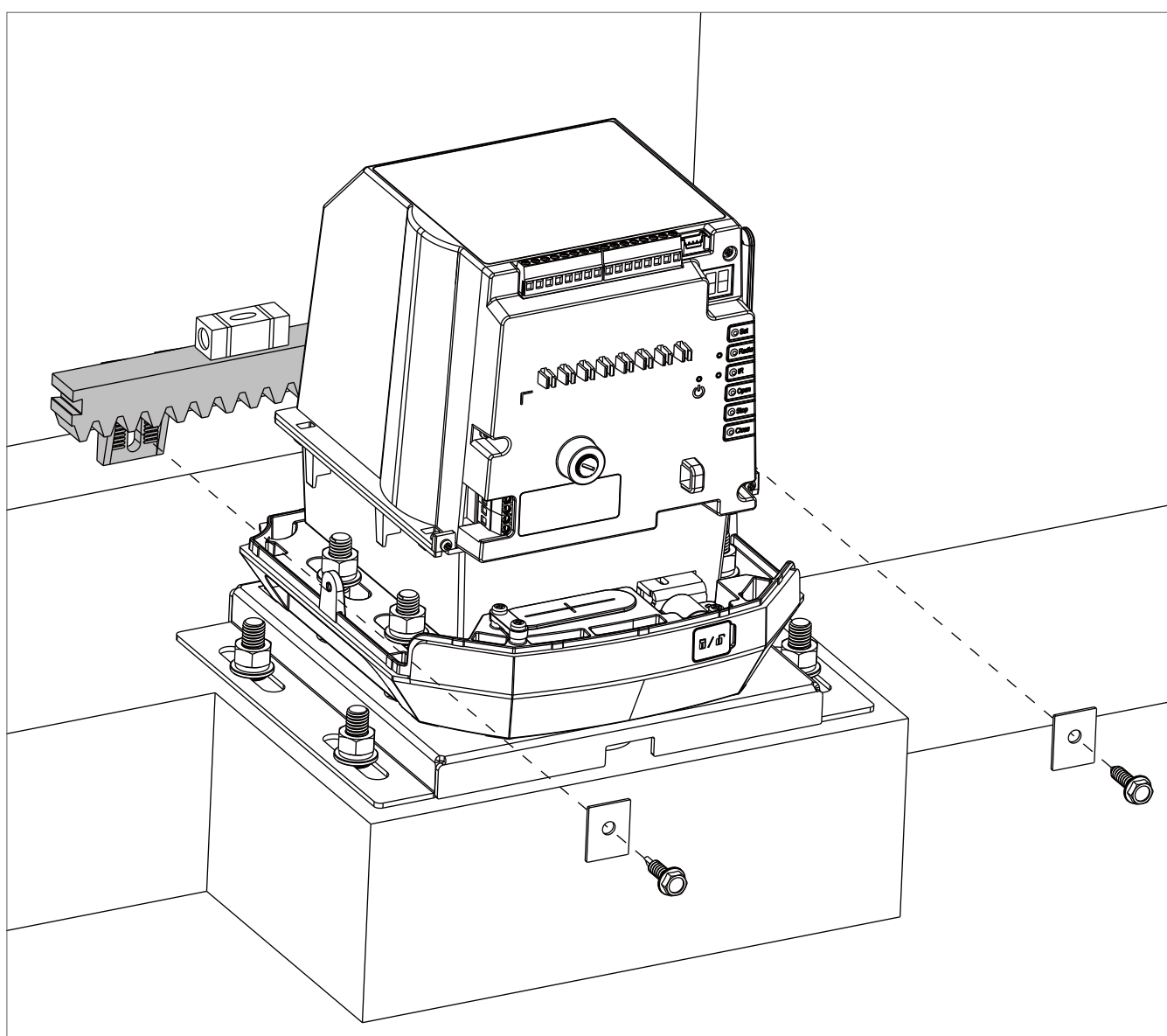

5. Fix the other gear racks in the same way, interlocking them with each other. (Do not fix the screws too tight.)

- i** When fixing each of the remaining gear racks, it is recommended to fix the screw on the far end first, then you may need to adjust the position of the gear rack before fixing the screw on the interlocking end.

6. After all the gear racks are fixed, it is recommended to slide the gate from end to end multiple times to check whether the gear racks and the toothed wheel work smoothly. If not, adjust the positions of the gear racks. After ensuring that the gear racks and the toothed wheel work smoothly, fix all screws on the gear racks nice and tight.

4. Fix the Limit Sheet Metal

- Slide the gate to the right end (regardless of whether the gate is open or closed or whether the gate opener is installed on the left or right).
- Take out the left limit sheet metal (with the "L" mark on the inner side) from the package.

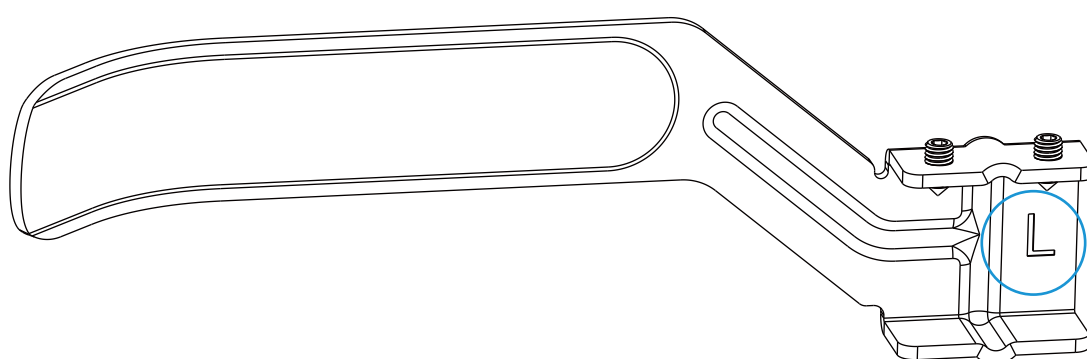

- Attach the left limit sheet metal onto the gear rack on the left side of the gate opener (ensuring that the bending part of the limit sheet metal is above the gear rack).
- Position the bending part of the limit sheet metal in contact with the limit spring on the gate opener.
- Push the limit sheet metal to bend the spring (as shown in the figure below) until you hear a click sound. Use the screws supplied to fix the limit sheet metal to the gear rack.

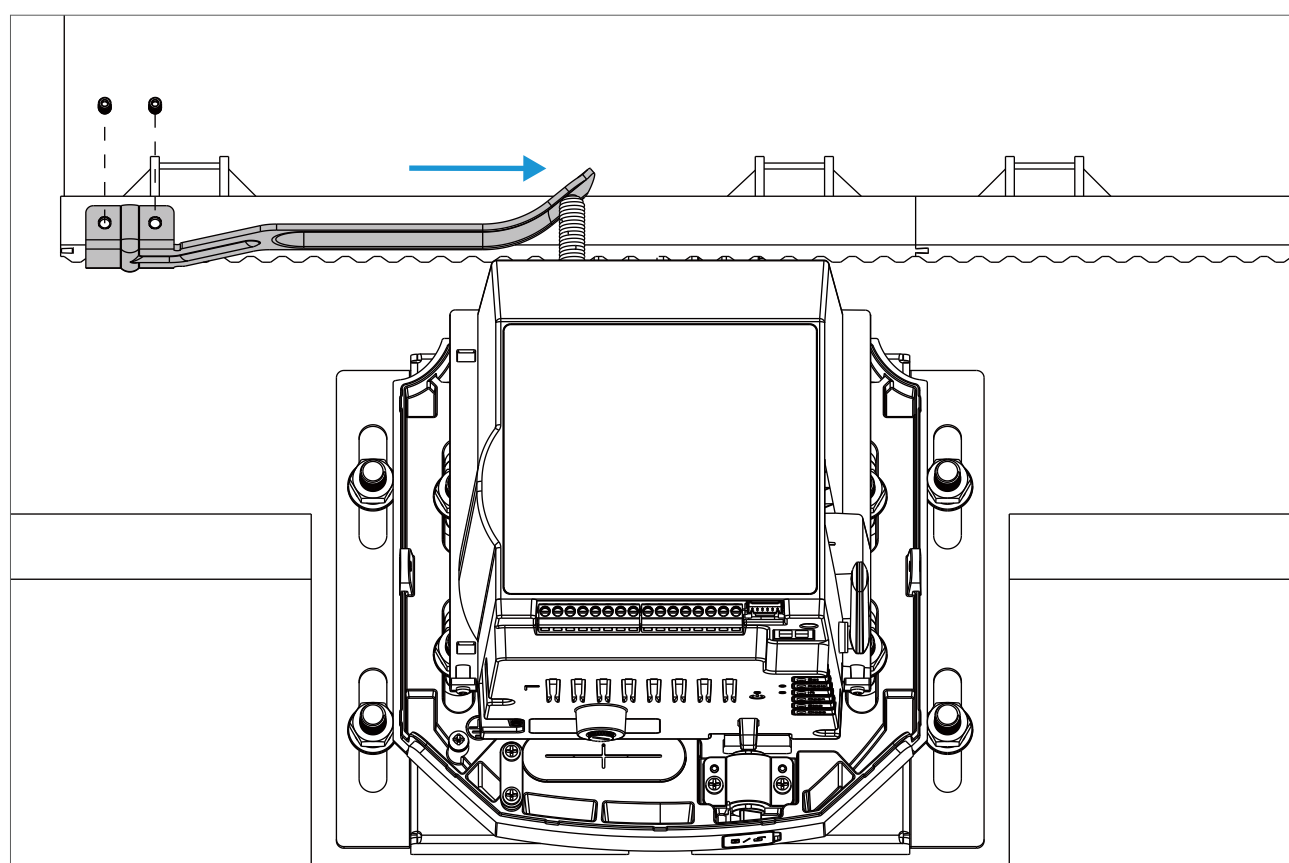

Fix the left limit sheet metal

Wrong Installation Examples

The bending part of the limit sheet metal is below the gear rack.

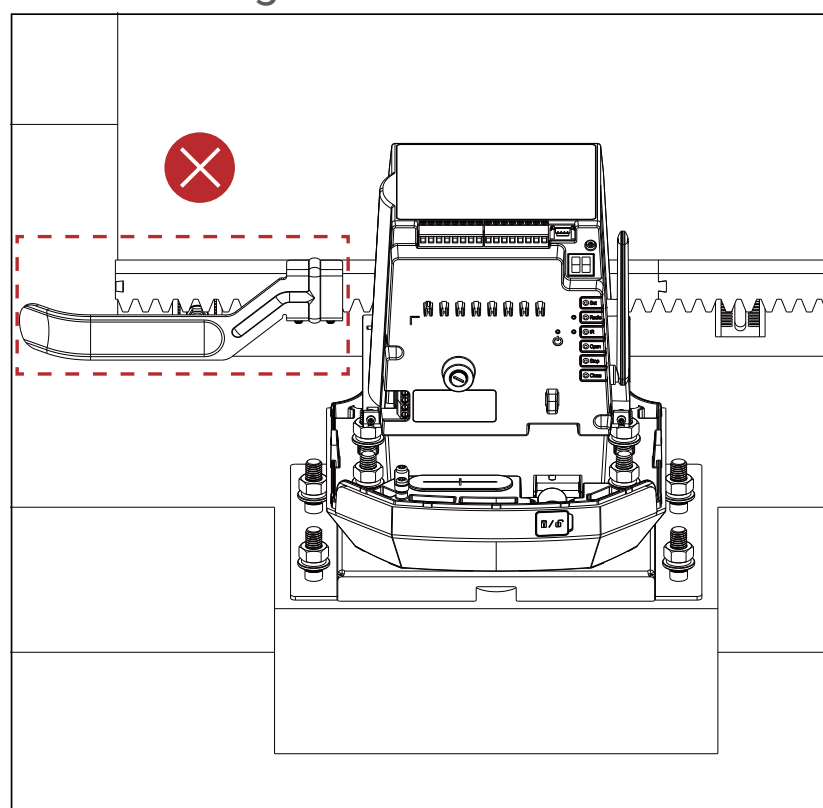

The bending part of the limit sheet metal is not in touch with the spring on the gate opener.

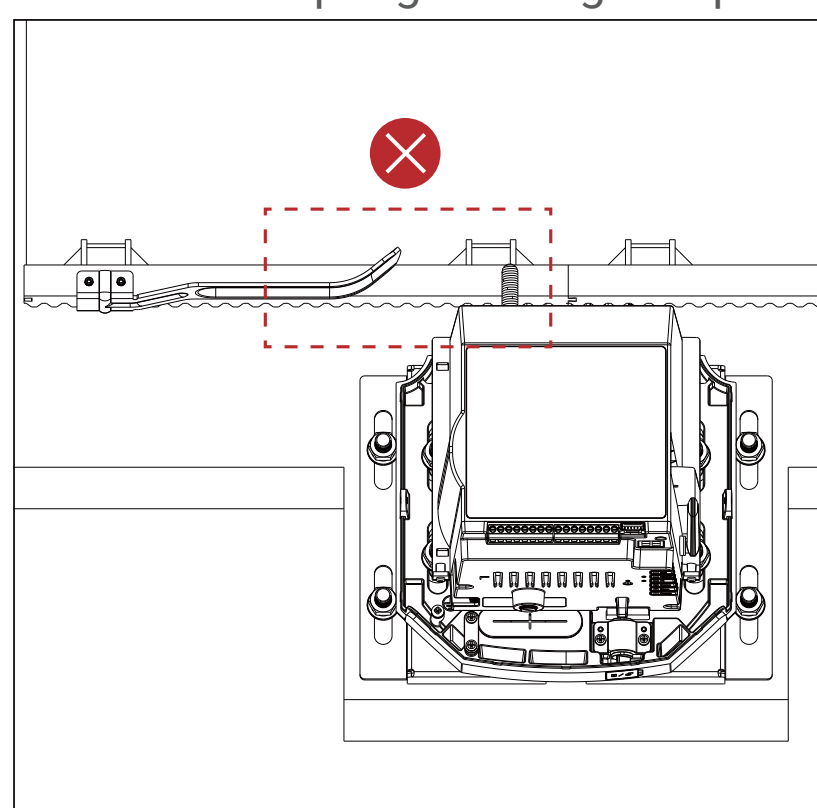

- Slide the gate to the left end and fix the right limit sheet metal in the same way.

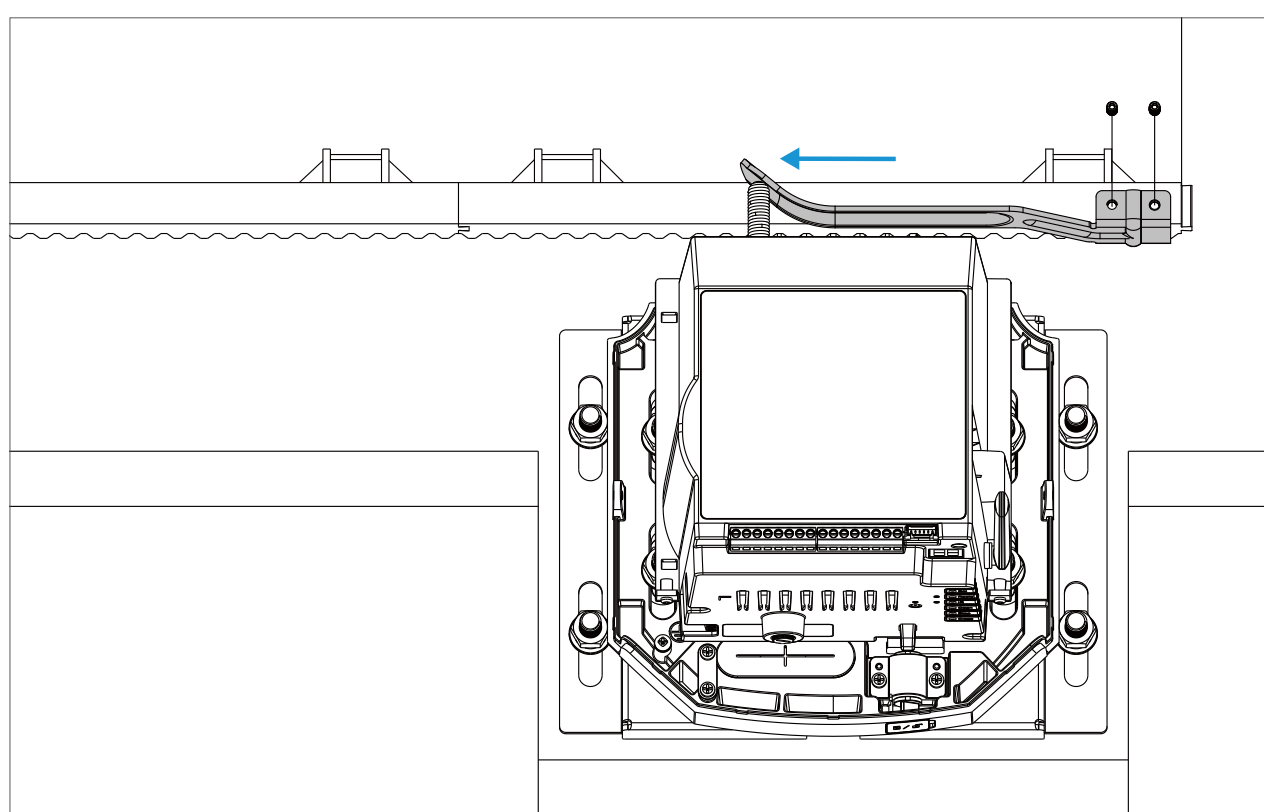

Fix the right limit sheet metal

- i** After fixing each piece of limit sheet metal, slide the gate slowly until the bending part of the limit sheet metal touches the limit spring on the gate opener to check whether a click sound can be heard. If not, adjust the position of the limit sheet metal.

How to deal with it if the limit sheet metal is too long and causes the gate unable to fully open or close?

- Manually bend the bending part of the limit sheet metal.
- Adjust the installation location of the gate opener.
- Extend the gate brace so that the limit sheet metal can be fixed further from the spring on the gate opener.
- Cut off part of the limit sheet metal.
- To avoid the situation that the limit sheet metal is too long and causes the gate unable to fully open or close, ensure that your gate is as longer than the distance between the pillars as possible.

5. Lock the Gate Opener

1. Open the keyhole cover and insert the key supplied.
2. Rotate the key counterclockwise for 180 degrees.
3. Pull out the key and place the keyhole cover back.

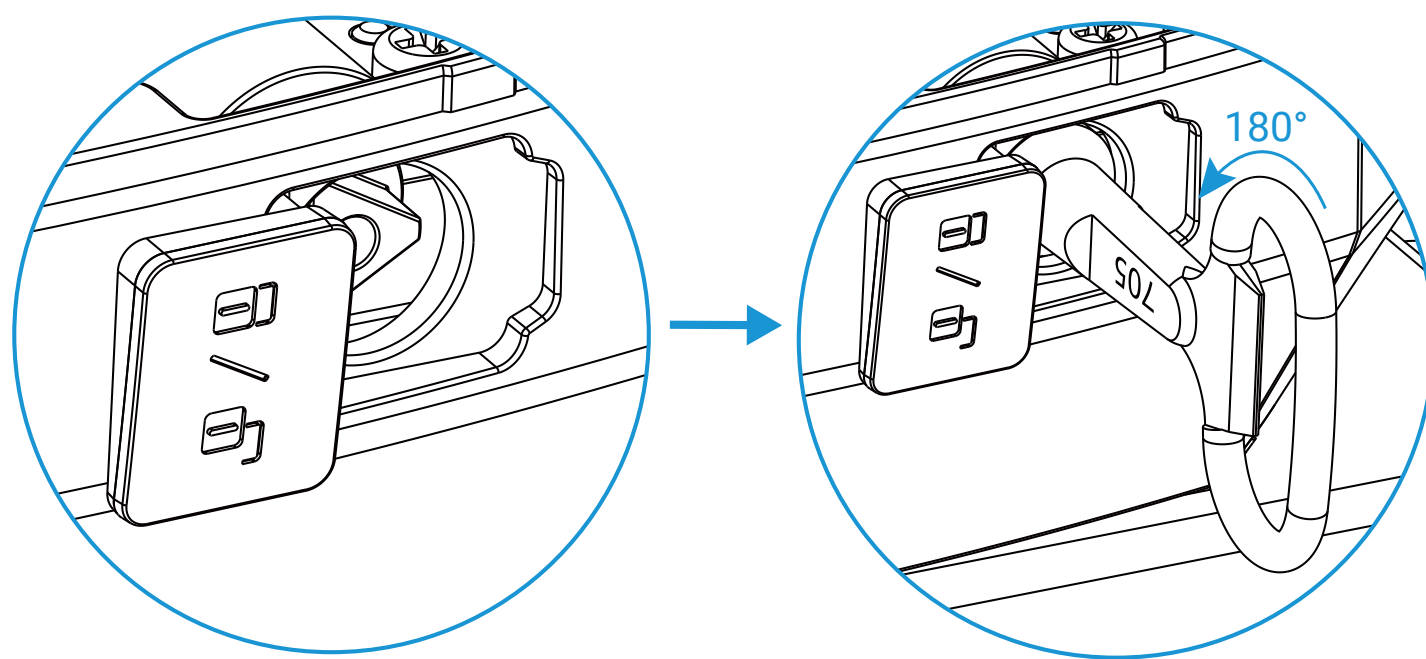

Install the Photocellules

Based on the emission of infrared beams, the photocellules are used to detect the passage of a person or vehicle through the gate to prevent from causing any harm or damage during gate closing. Cutting the photocellule beam should cause the gate to stop immediately.

1. Components Required

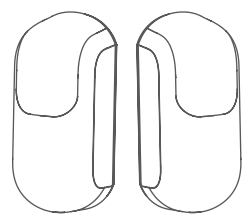

Photocellule (x2)

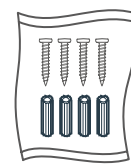

Screw Kit (x1)

2. Basics of Photocellules

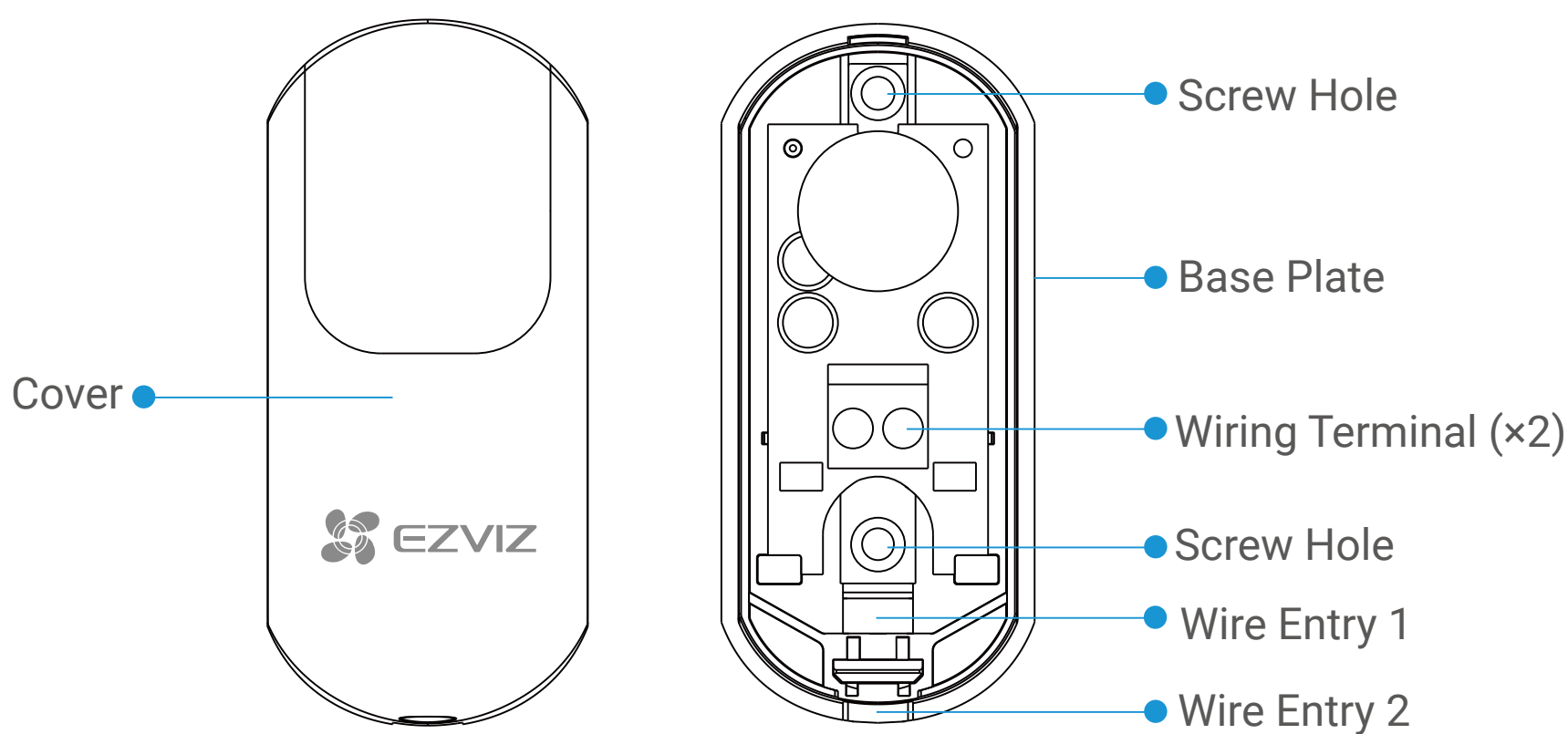

3. Installation Procedure

- Do not install the photocellules onto unstable surfaces.
- If you install the photocellules where there are direct light rays or sunlight, measures should be taken to protect the internal optical components of the photocellules from the light rays or sunlight.
- The photocellule RX should only receive light rays emitted by the photocellule TX. Do not direct infrared light rays emitted by other detectors at the photocellule RX.
- Be sure to install the two photocellules at the same and appropriate height (recommended height: 0.5 meters above the ground).
- Recommended horizontal distance between the photocellules: 3-8m.
- Two pairs of photocellules can be installed at most. Do not install two TXs (or RXs) on the same side.

Preparation

1. If any existing photocellules are installed on the pillar, remove them first. The wires can be retained for use.
2. Ensure that the environment meets the installation requirement. Use a tape measure to help determine an appropriate installation location on the pillar. It is recommended that the photocellules should be installed at a height of about 50cm above the ground and the photocellules can be installed either inside the gate or outside the gate on the pillar.
3. One pair of photocellules are provided in the package. The two photocellules should be installed on both pillars separately, with no specific requirements on which pillar the TX or RX should be installed.
4. Each photocellule requires two wires for connection to the gate opener. If there are four concealed wires, choose any two of them.

Install the photocellules

1. Take the photocellule (TX or RX) out of the box. Use a screwdriver to loosen the screw on the bottom of the cover. (Keep the screw properly.)

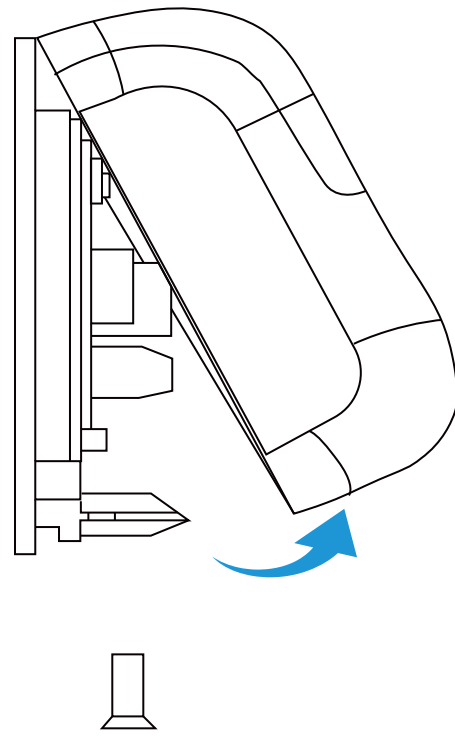

2. Grab the lower part of the cover and flip it upwards to separate the cover from the base plate.
3. Use the base plate and a tape measure to select an appropriate installation location on the pillar. It is recommended that the location should be at a height of about 50cm above the ground (as shown below).

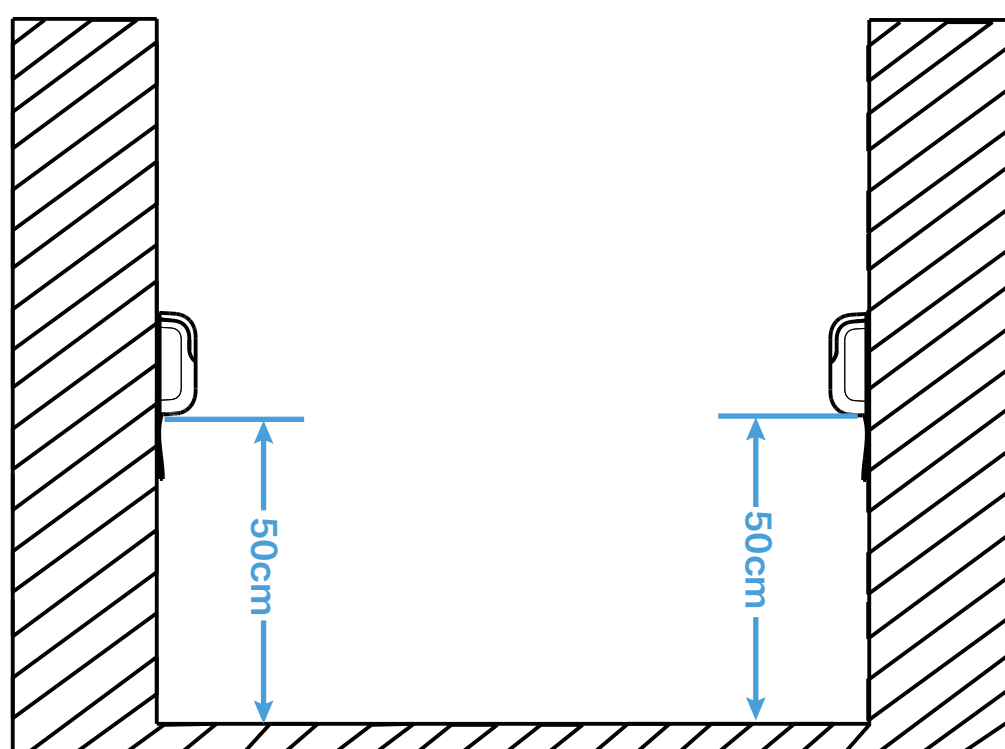

i The photocellules can be installed either inside the gate or outside the gate on the pillar.

4. Use a marker to mark two anchoring points according to the two screw holes on the base plate.
5. Take the base plate away and use a drill bit to drill two holes (drilling depth: 25-30mm) at the two anchoring points.
6. Connect wires.
 - a. Loosen the two screws on the wiring terminals.
 - b. Guide two wires through the wire entry 1 (if you are using concealed wiring) or wire entry 2 (if you are using visible wiring) and insert them into the wiring terminals separately.

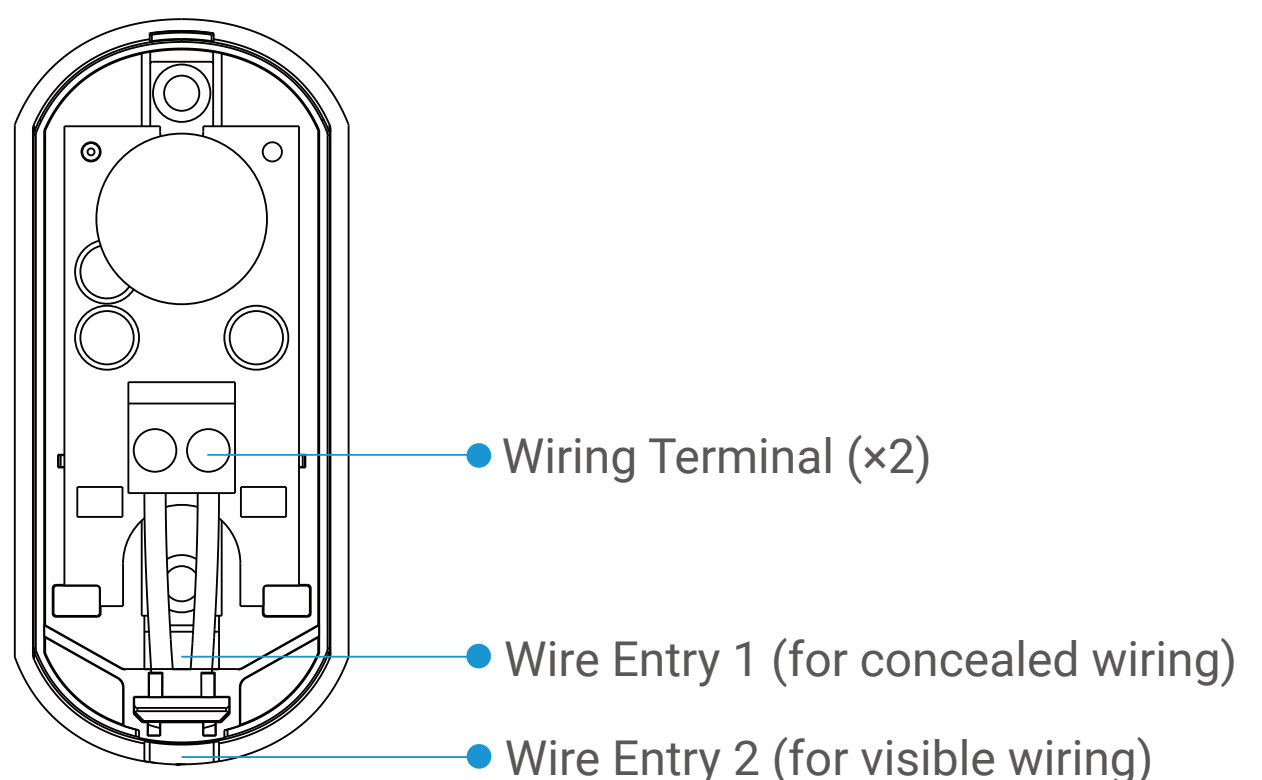

- c. Tighten the two screws back on the wiring terminals.

i

- The two wiring terminals on the base plate are polarity-insensitive.
- Make sure that the screws are tightened properly and the wires will not fall off.
- Be careful not to short-circuit the two wires.

7. Insert two anchors into the holes on the pillar and hammer them just into the holes.
8. Align the two screw holes of the base plate with the two holes on the pillar and fix two screws into the screw holes.

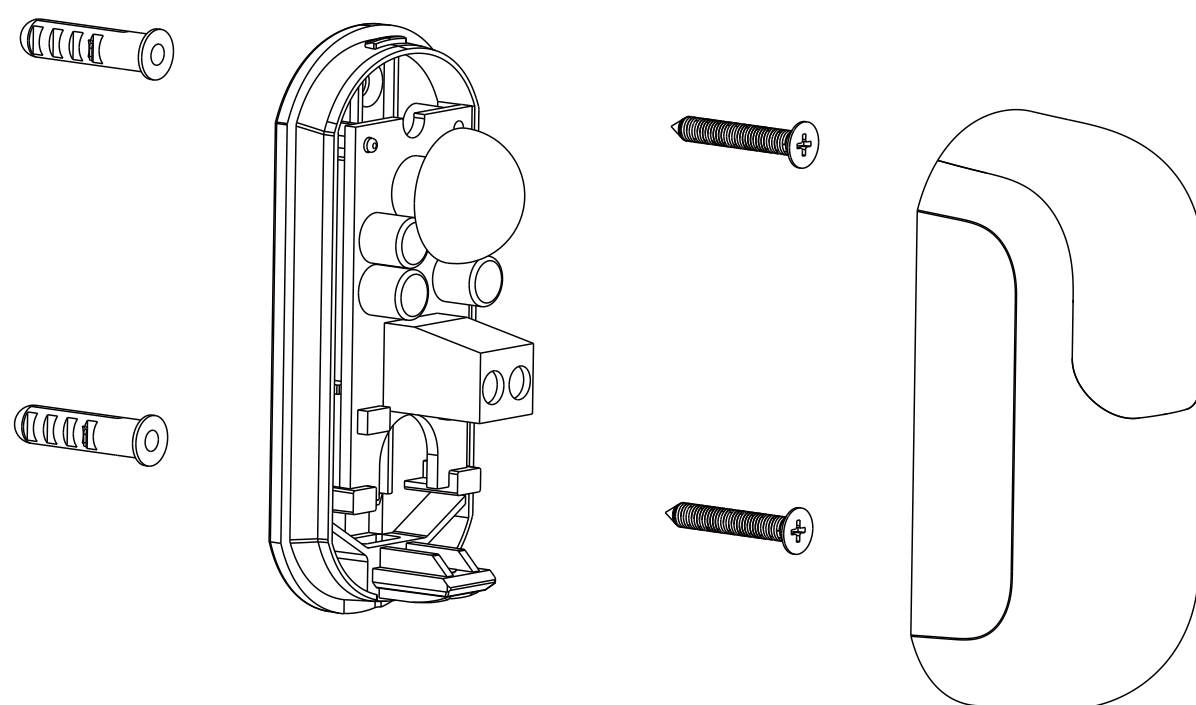

9. Install the cover onto the base plate (from the top down) and tighten the screw back (loosened in step 1) on the bottom of the cover.

After one photocell is installed, repeat the steps above to install the other photocell, making sure that the two photocells are fixed at the same height and the two photocells are aligned as shown below.

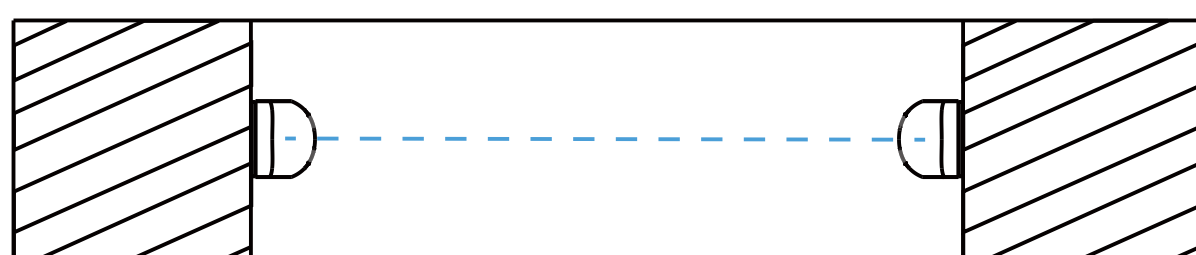

Top View

Wiring on the gate opener

1. Loosen the two screws on the terminals 7 and 8 ("BUS") on the gate opener.
 2. Insert the two wires of one photocell into the terminals 7 and 8.
- Do not insert the two wires into the same terminal.
 - Make sure that the screws are tightened properly and the wires will not fall off.
 - Be careful not to short-circuit the two wires of the same photocell.
3. Insert the two wires of the other photocell into the terminals 7 and 8.
 4. Tighten the screws back on the two terminals.
 5. Use a cable tie to fix the wires in the cable holder.

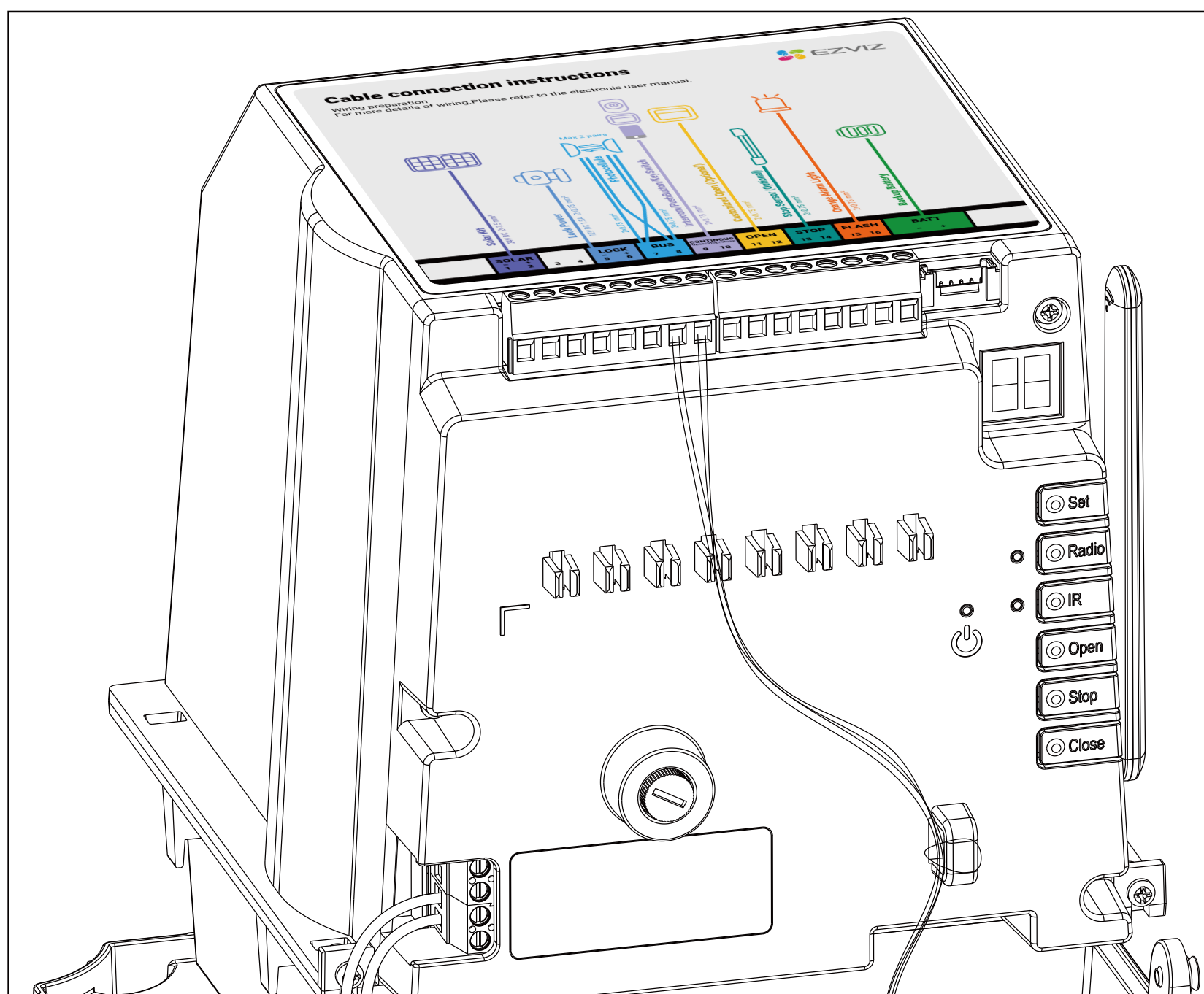
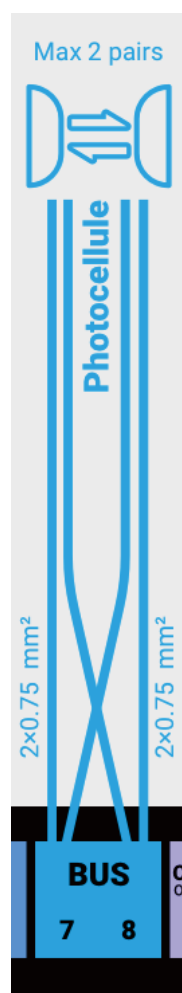

Install the Alarm Light

1. Components Required

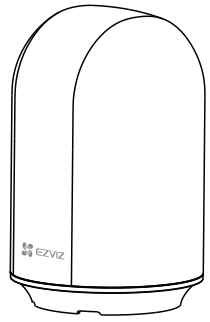

Alarm Light (×1)

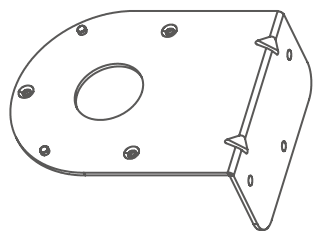

Wall Bracket (×1)

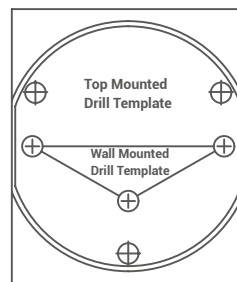

Drill Template (×1)

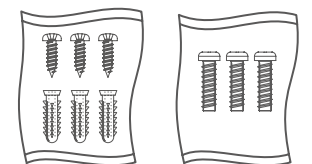

Screw Kit (×2)

2. Basics of Alarm Light

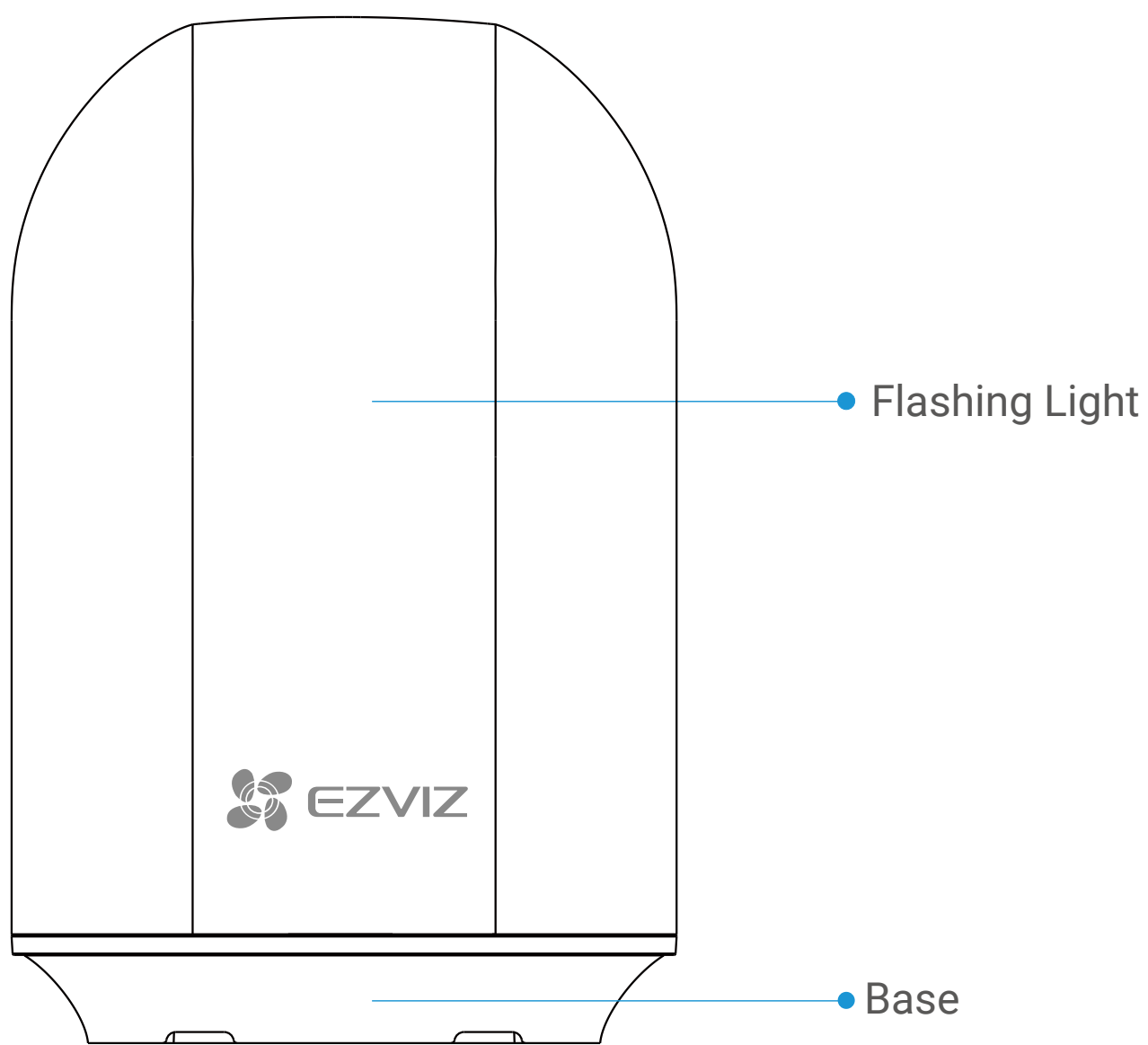

Front View

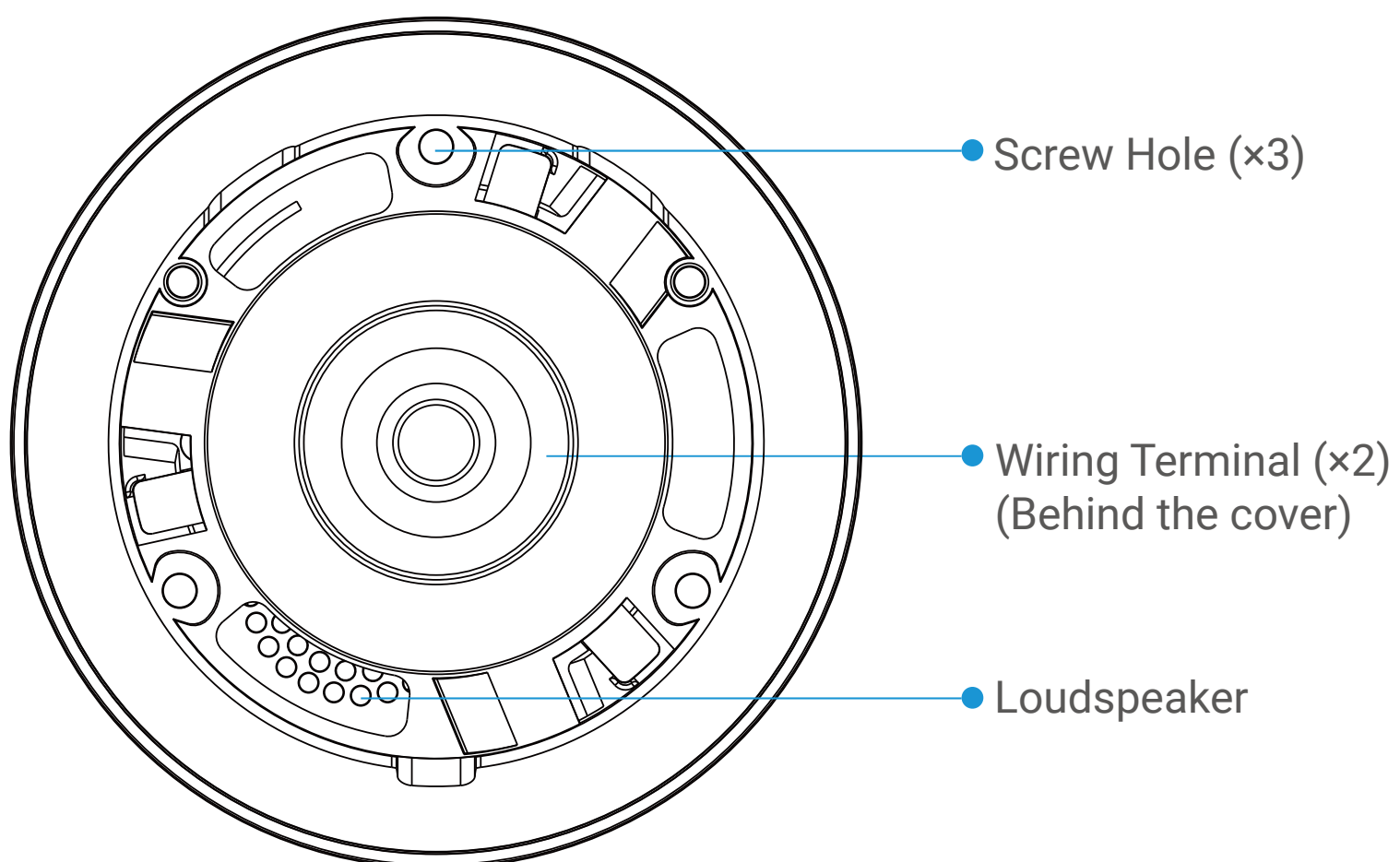

Bottom View

3. Installation Procedure

- i** It is recommended to install the alarm light on the same side as the gate opener, which is the side to which the gate opens.

Preparation

1. If any existing alarm light is installed on the pillar, remove it first. The wires can be retained for use.
2. The alarm light requires two wires for connection to the gate opener. If there are no wires, please drill holes and get wires ready first.
3. Choose between top mounting and wall mounting based on the structure of your gate and pillars.

Top mounting

1. Choose an appropriate installation location on top of the pillar and stick the drill template (ensuring that the installation area is clean and flat).
2. Use a drill bit (5.5mm diameter) to drill holes according to the three points along the circle on the drill template (drilling depth: about 25mm).

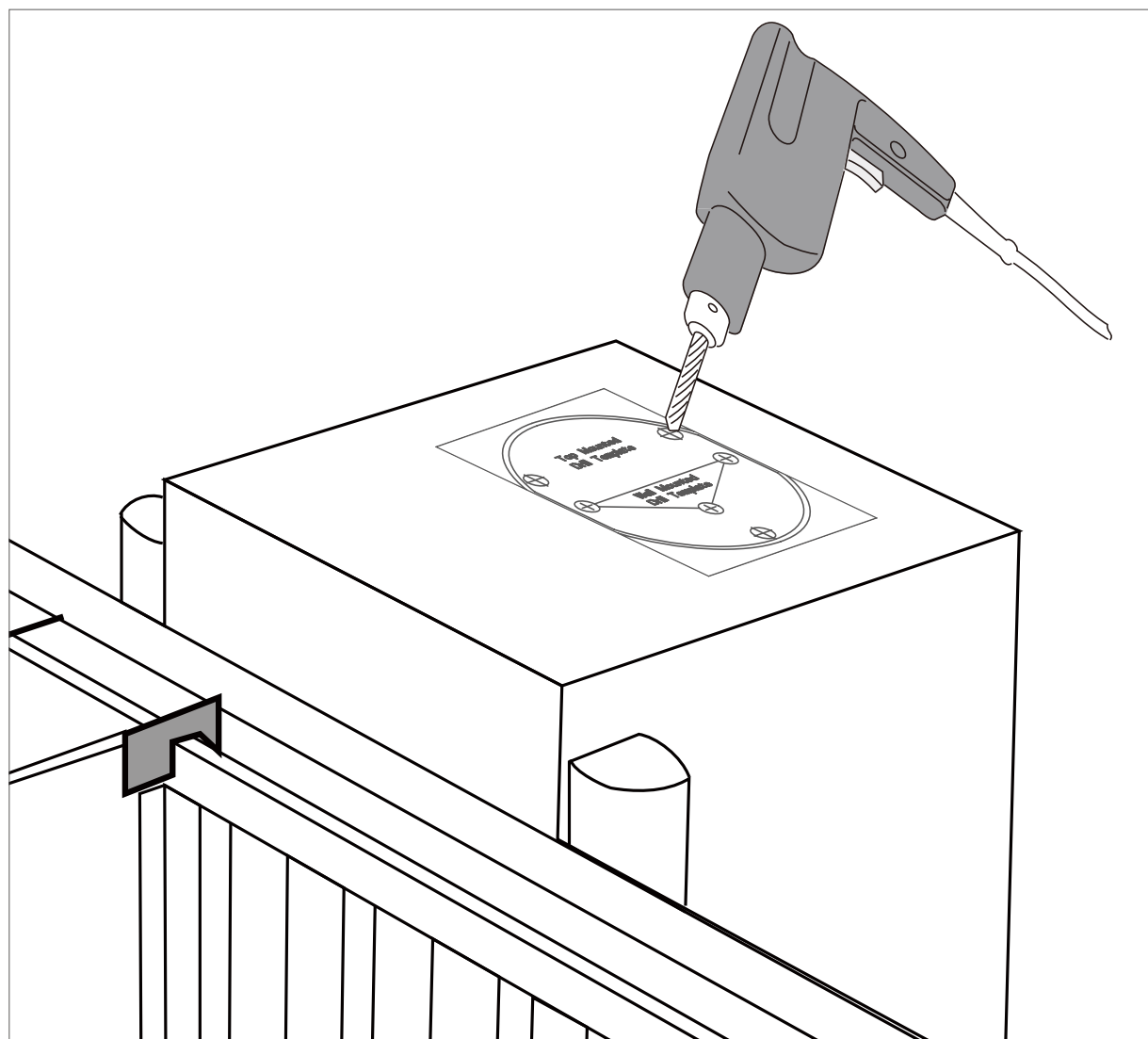

3. Remove the drill template, put anchors in the holes, and hammer them just into the holes.

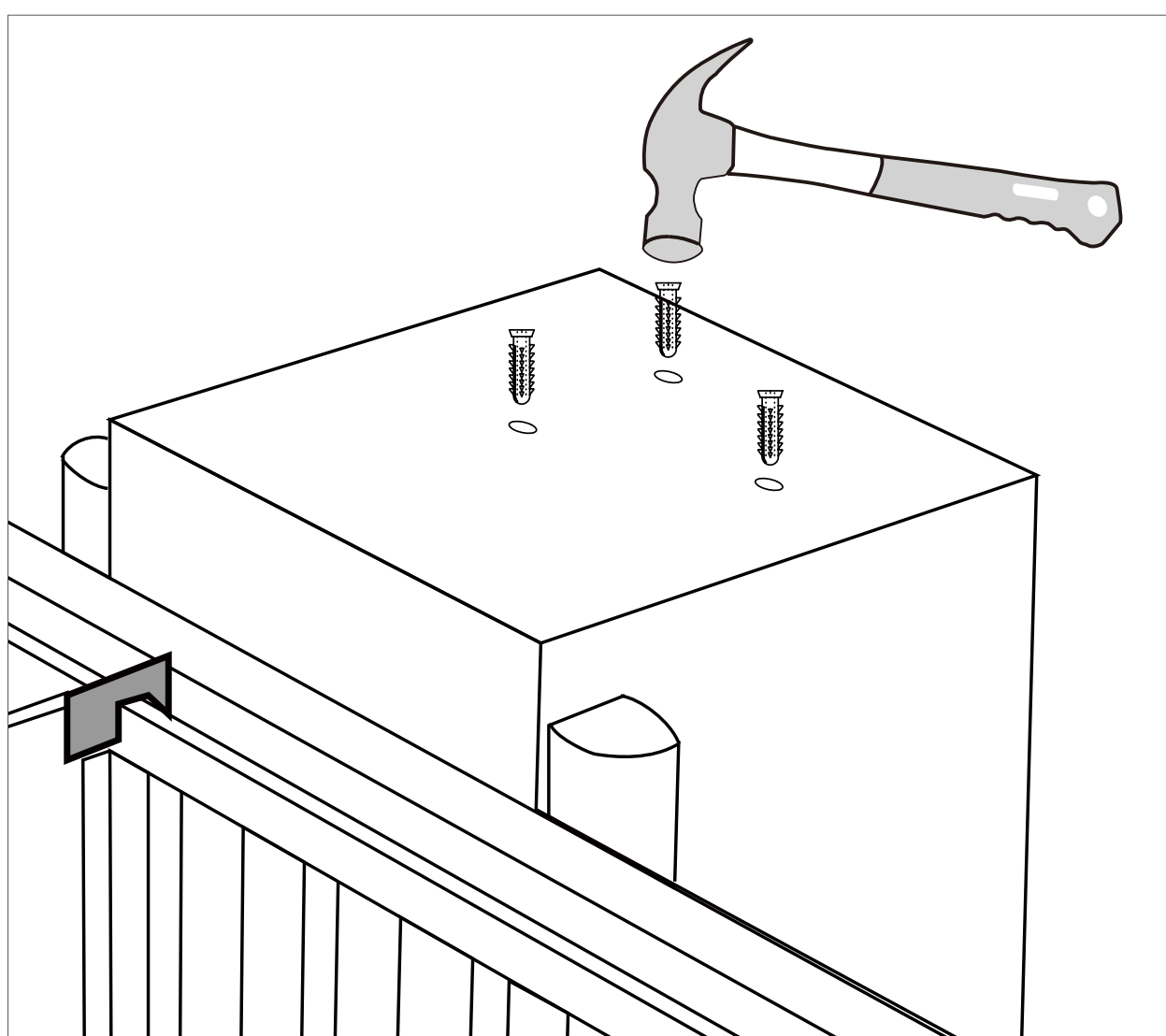

4. Rotate the base of the alarm light counterclockwise to separate the base from the flashing light.

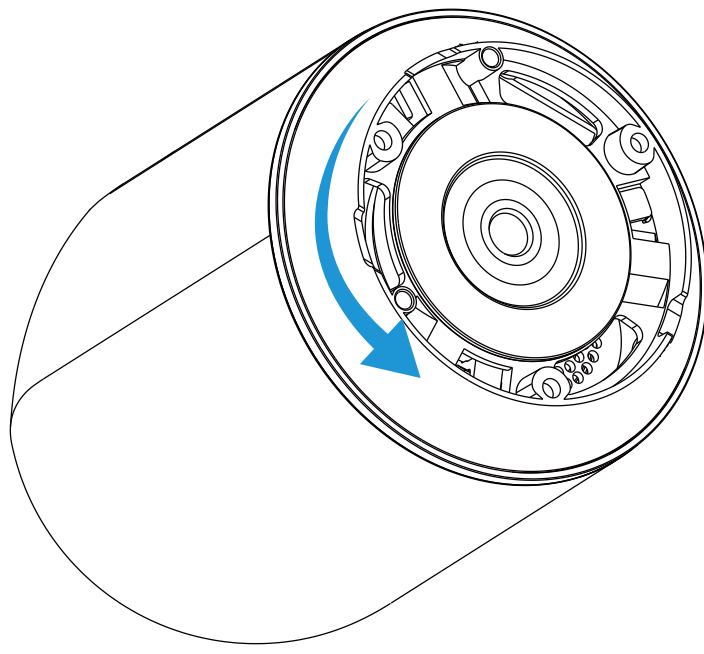

5. Poke a hole in the center of the silicone cover of the base for the wire to go through.
6. Peel off the insulating sheath of two concealed wires for 6-10mm and pass the wires through the hole in the silicone cover.
7. Align the three screw holes on the base with the drilled holes on top of the pillar. Use three screws to fix the base.

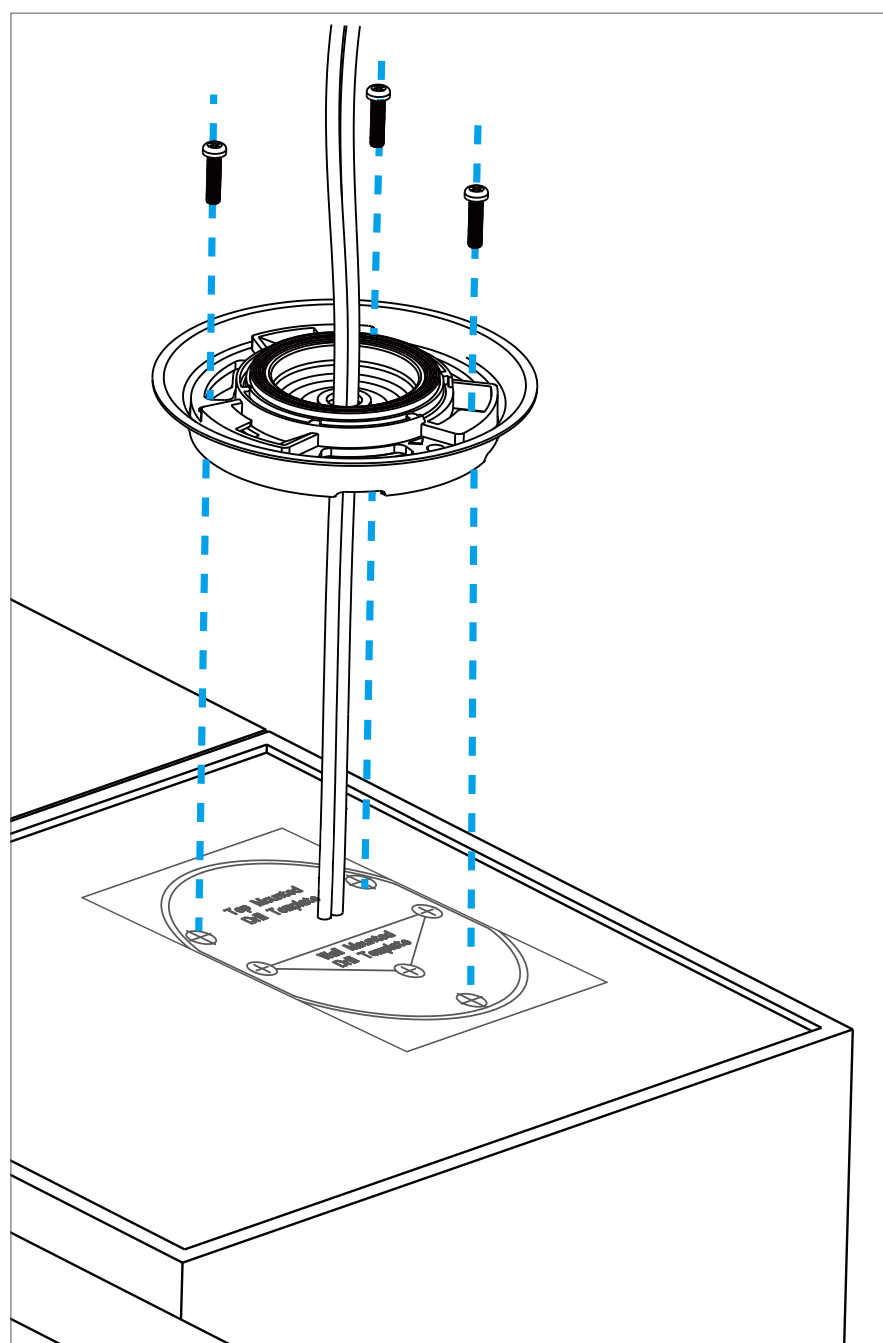

8. Connect the wires to the alarm light.
 - a. Use a screwdriver to loosen the two screws on the two wiring terminals.
 - b. Connect the wires to the two wiring terminals (polarity-insensitive).

i Be careful not to short-circuit the wires.

- c. Use a screwdriver to tighten the screws back on the wiring terminals.

9. Align the arrow sign on the bottom of the flashing light with the arrow on the base and rotate the flashing light clockwise. The flashing light will be fixed on the base.

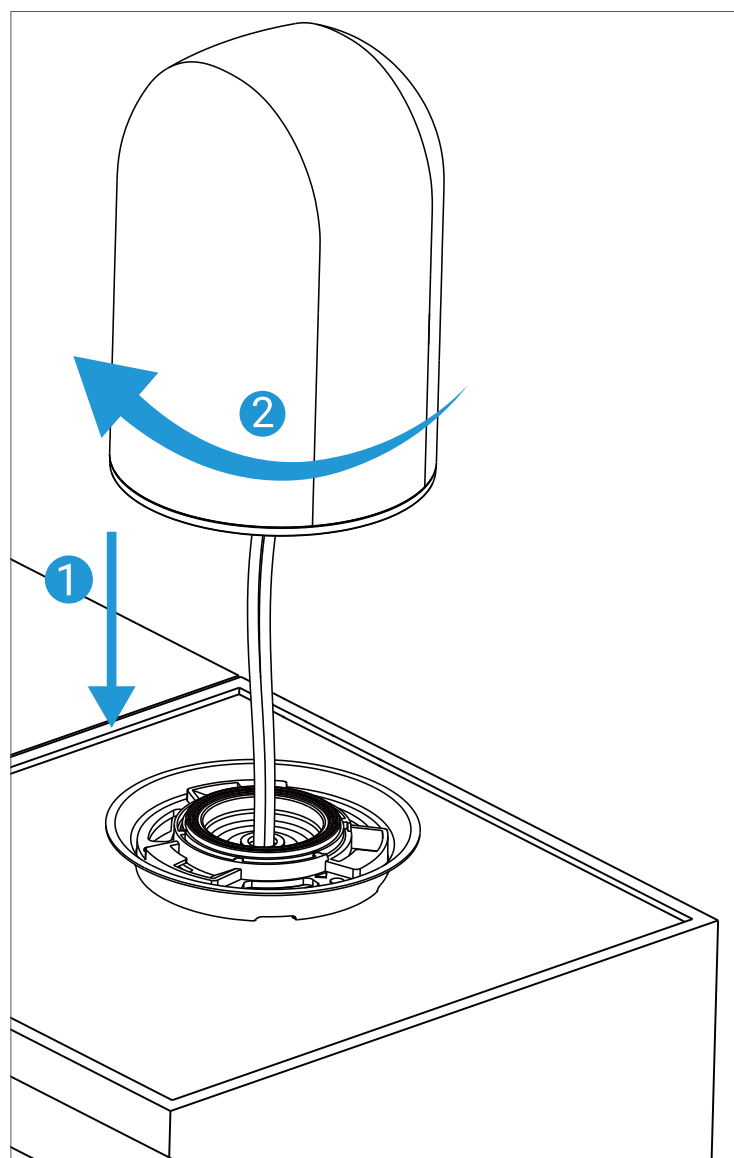

Wall Mounting

If your gate and pillars are not suitable for top mounting, you can use wall mounting.

- i** • For wall mounting, it is recommended that the alarm light should be installed at a height of 1.5 to 2.5 meters.
- Operation details of wall mounting are similar to those of top mounting and therefore are not repeated here.

1. Separate the base from the flashing light and fix the base onto the wall bracket (included in the package).
2. Choose an appropriate installation location on the wall of the pillar and install the wall bracket.
3. Connect wires and fix the flashing light on the wall bracket.

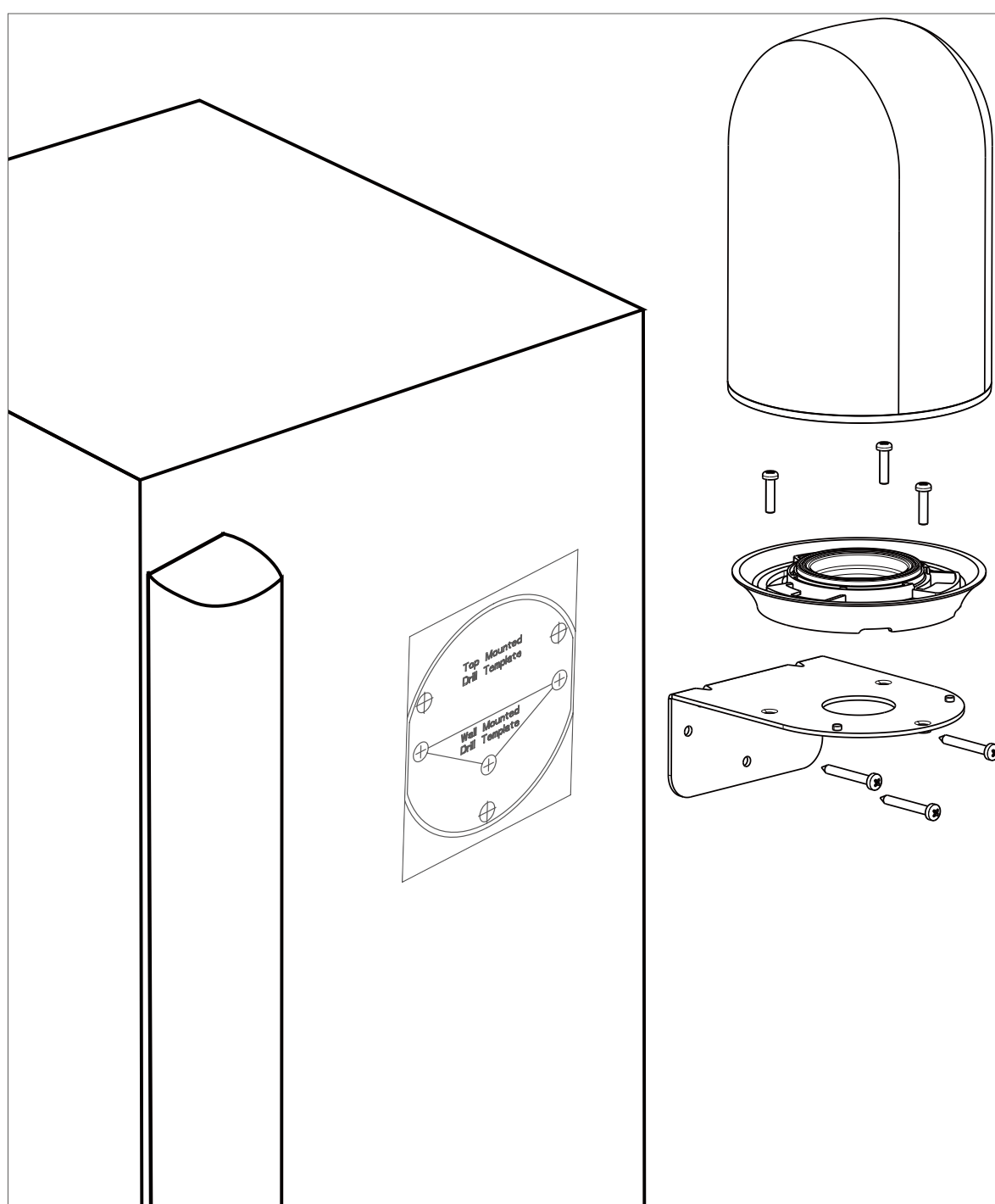

Wiring on the gate opener

1. Loosen the two screws on the terminals 15 and 16 ("FLASH") on the gate opener.
2. Insert the two wires of the alarm light into the terminals 15 and 16 separately.
3. Tighten the screws back on the two terminals.

- i** • Make sure that the screws are tightened properly and the wires will not fall off.
- Be careful not to short-circuit the wires.

4. Use a cable tie to fix the wires in the cable holder.



Orange Alarm Light
2x0.75 mm²

FLASH

15 16

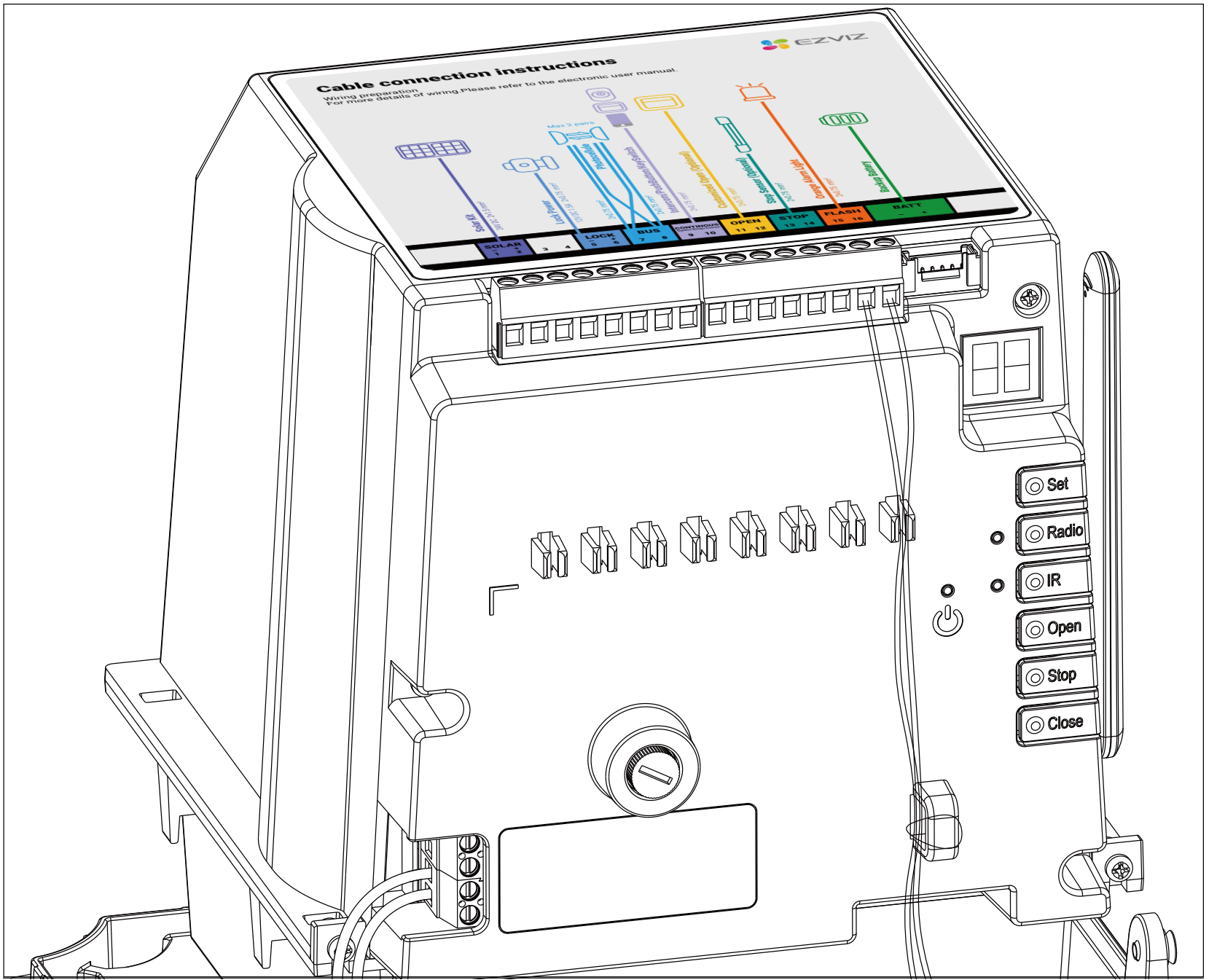

Install Other Components (Optional)

This gate opener can also be connected to the following external devices to achieve corresponding purposes.

| External Device | Purpose |
|---------------------------------------|--|
| Intercom panel/push button/key switch | Control the gate movement in the "Open-Stop-Close" sequence. |
| Customized open controller | Open the gate by using external control signals. You can customize the opening mode (including 1/4 Open, 1/2 Open, 3/4 Open, and Fully Open) in the EZVIZ app. |
| Stop sensor/emergency stop button | Stop the gate immediately whenever the gate hits an obstacle or in emergencies. |
| Electric strike plate | Supply 12V DC power to an electric strike plate (without providing control signals). |
| Area lighting | Supply power to a spotlight. |

1. Connect to Intercom Panel, Push Button or Key Switch

If you have any intercom panel, push button, or key switch, you can connect them to this gate opener so that you can control the gate movement by using these devices.

After successful connection, each time the gate opener receives a control signal from the connected intercom panel, push button, or key switch, the gate opener controls the gate in the "Open-Stop-Close" sequence.

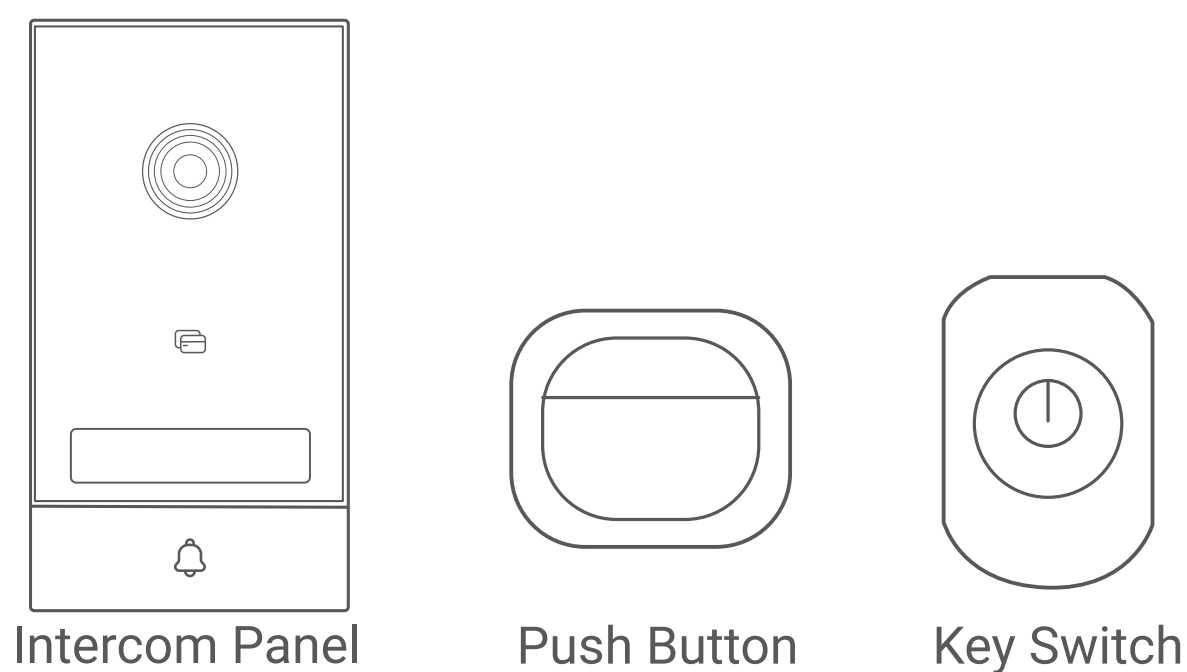

Connect the wires of your device to terminals 9 and 10 ("CONTINUOUS") on the gate opener.

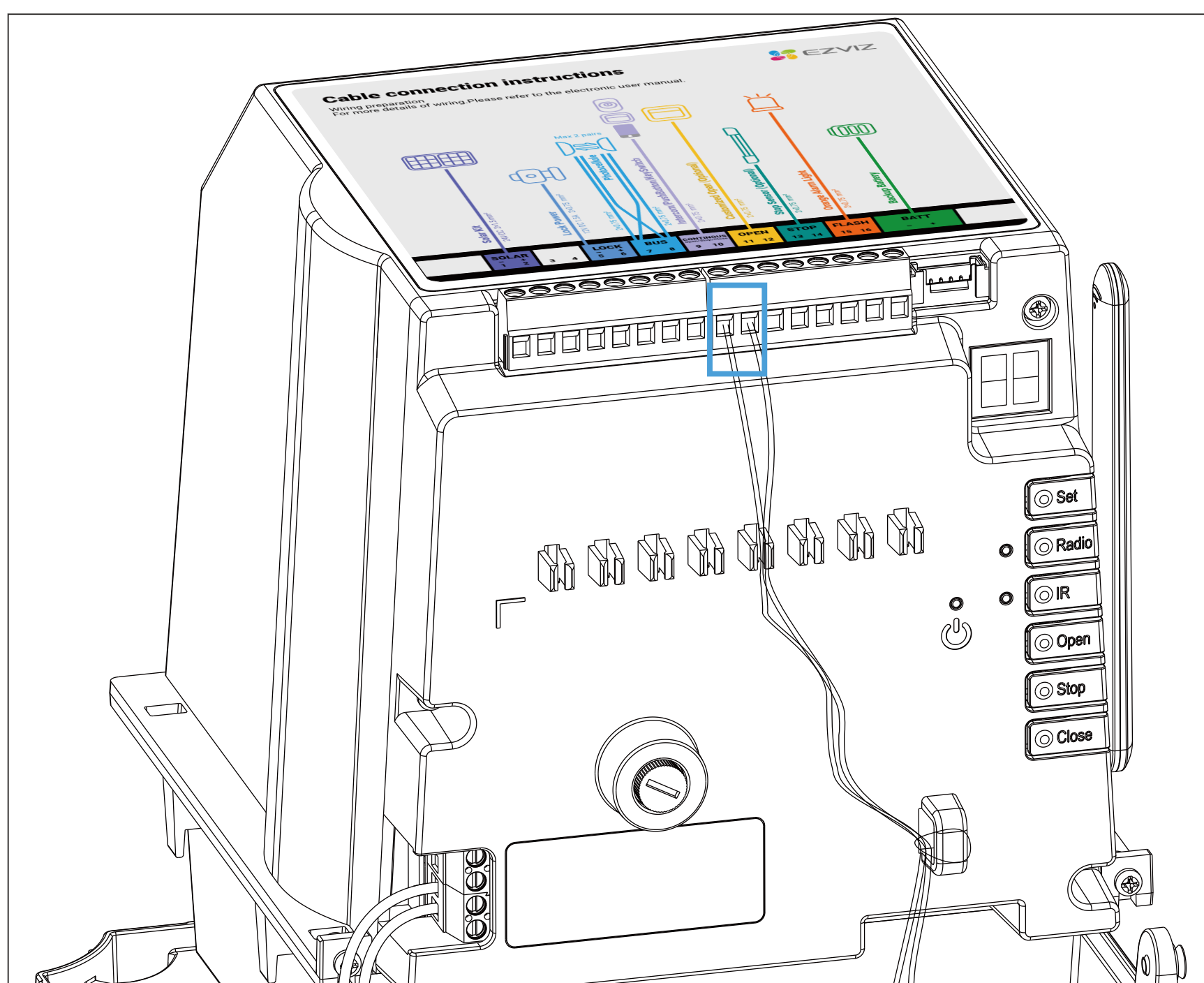

- The "CONTINUOUS" terminals are polarity-insensitive.
- Multiple devices can be connected to the "CONTINUOUS" terminals at the same time.

2. Connect to Customized Open Controller

In certain scenarios you may need more customized gate opening, such as when you only need the gate to be 1/4 open to let a person in. In these cases, you can connect a customized open controller to this gate opener and select a customized opening mode (1/4 Open, 1/2 Open, 3/4 Open, or Fully Open; default mode: 1/4 Open) as you need in the EZVIZ app to realize customized gate opening.

1. Connect the wires of your customized open controller to terminals 11 and 12 ("OPEN") on the gate opener.

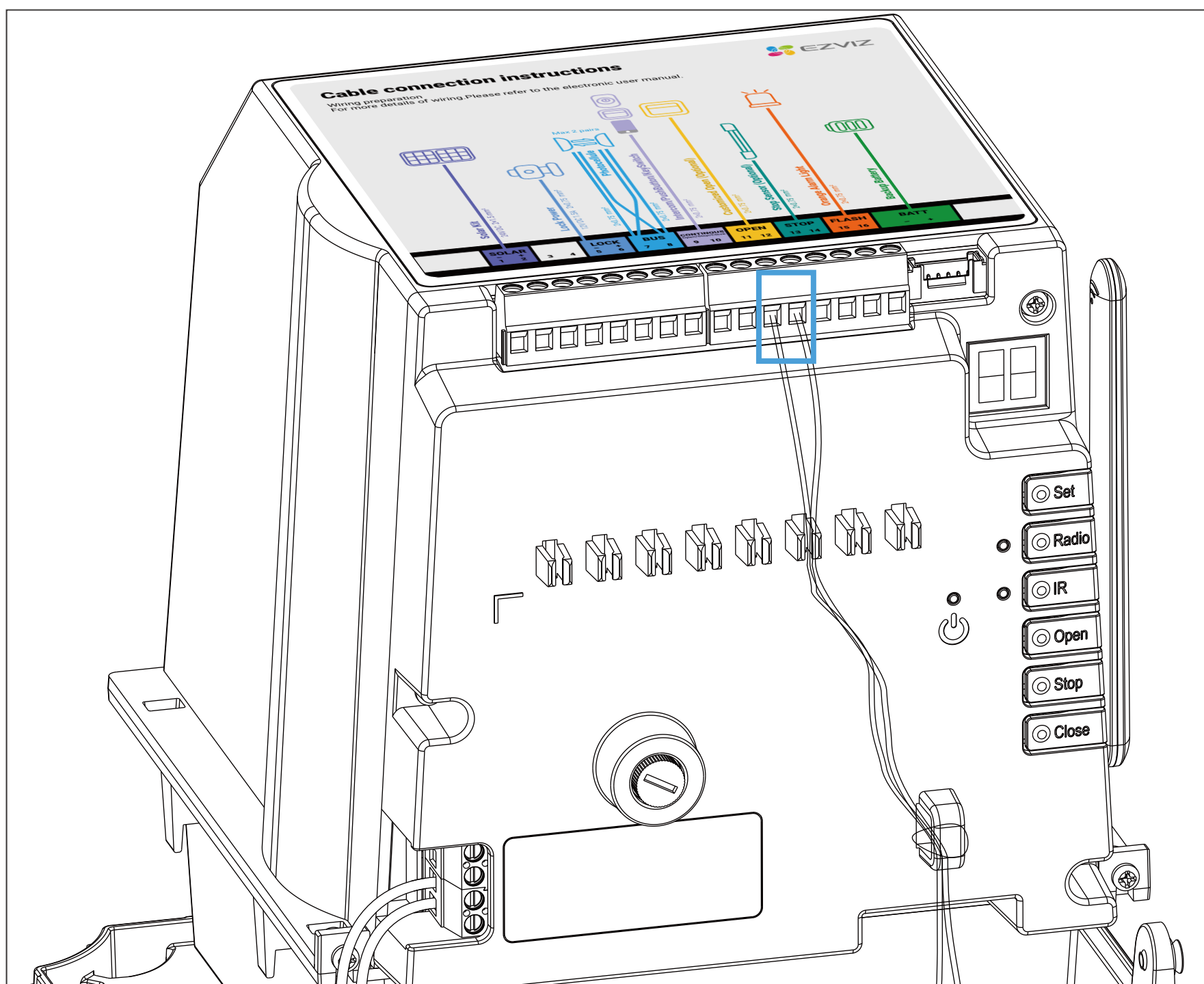

2. In the EZVIZ app, go to the gate opener settings page, select "Gate Opening/Closing Settings" > "Customize Button Setting".
3. Select a customized opening mode as needed.

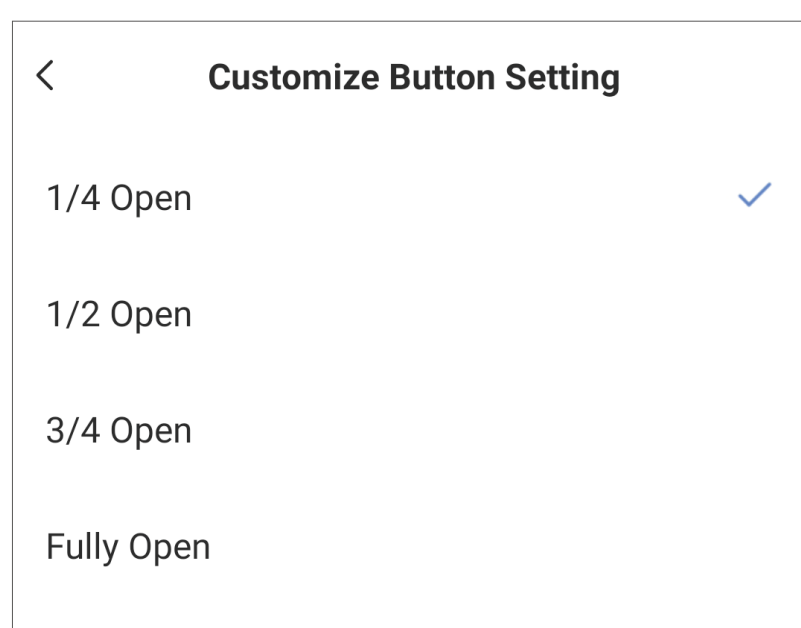

- The "OPEN" terminals are polarity-insensitive.
- Multiple devices can be connected to the "OPEN" terminals at the same time.
- After successful connection, each time the gate opener receives a control signal from the connected customized open controller, the gate opener opens the gate immediately.

3. Connect to Stop Sensor or Emergency Stop Button

For safety considerations, it is recommended to use a stop sensor or an emergency stop button to prevent gate movement from causing personal injuries.

- If your force limiter on the gate frame does not have an embedded stop sensor, you're advised to install a stop sensor on the force limiter (as shown in the

4. Connect to Electric Strike Plate

If you have an electric strike plate connected to your intercom panel, the power consumption of the electric strike plate may be large and the intercom panel may not be able to provide enough power to the strike plate. In this case, you can connect the electric strike plate to the gate opener, so that the gate opener can serve as a power supply to provide 12V DC power for the electric strike plate (as shown in the figure below).

Note that the gate opener only serves as a power supply and does not send control signals to the electric strike plate.

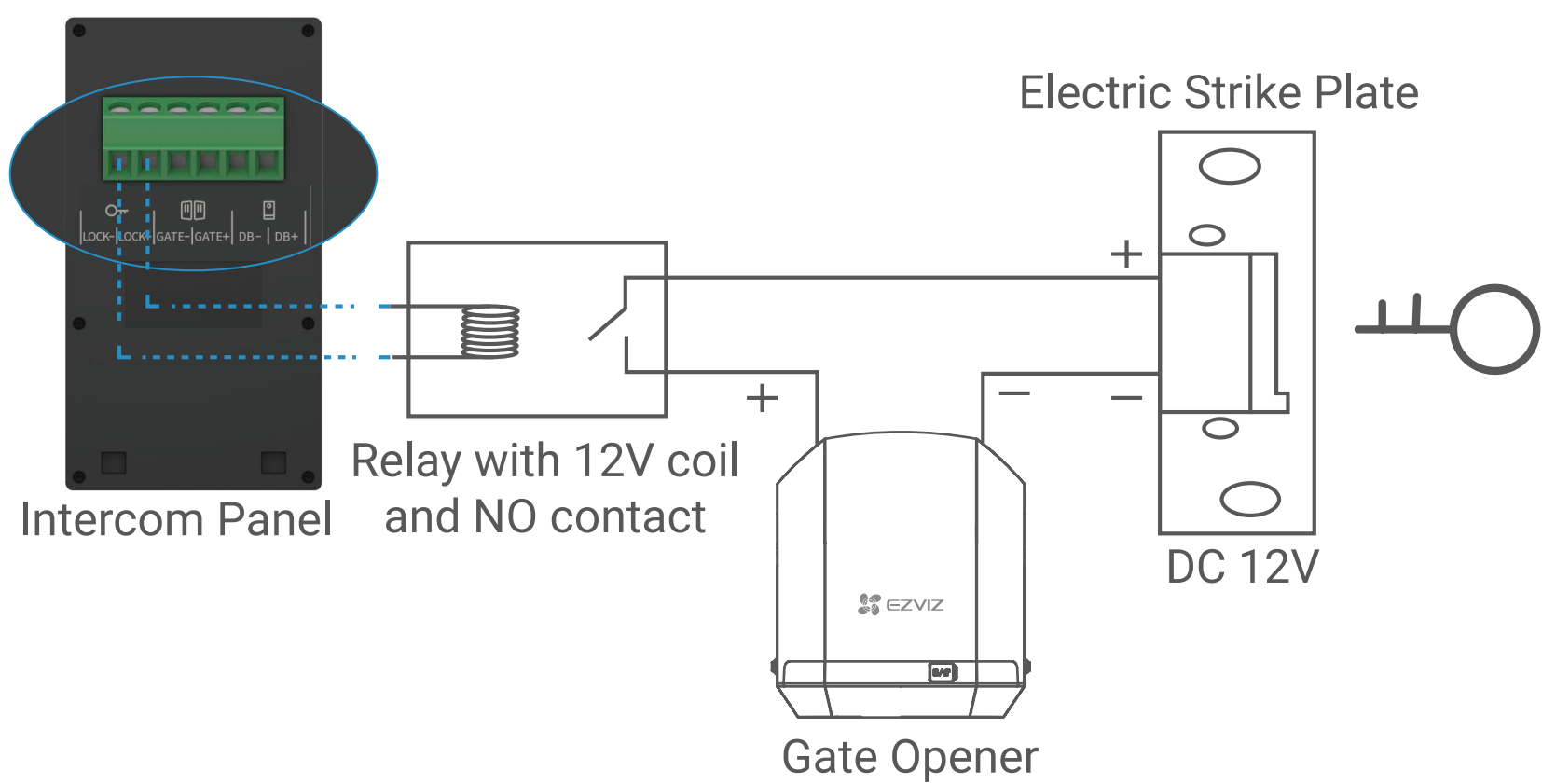

Connect the wires of your electric strike plate to terminals 5 and 6 ("LOCK") on the gate opener. Make sure to connect the positive wire to the terminal 6 and the negative wire to the terminal 5.

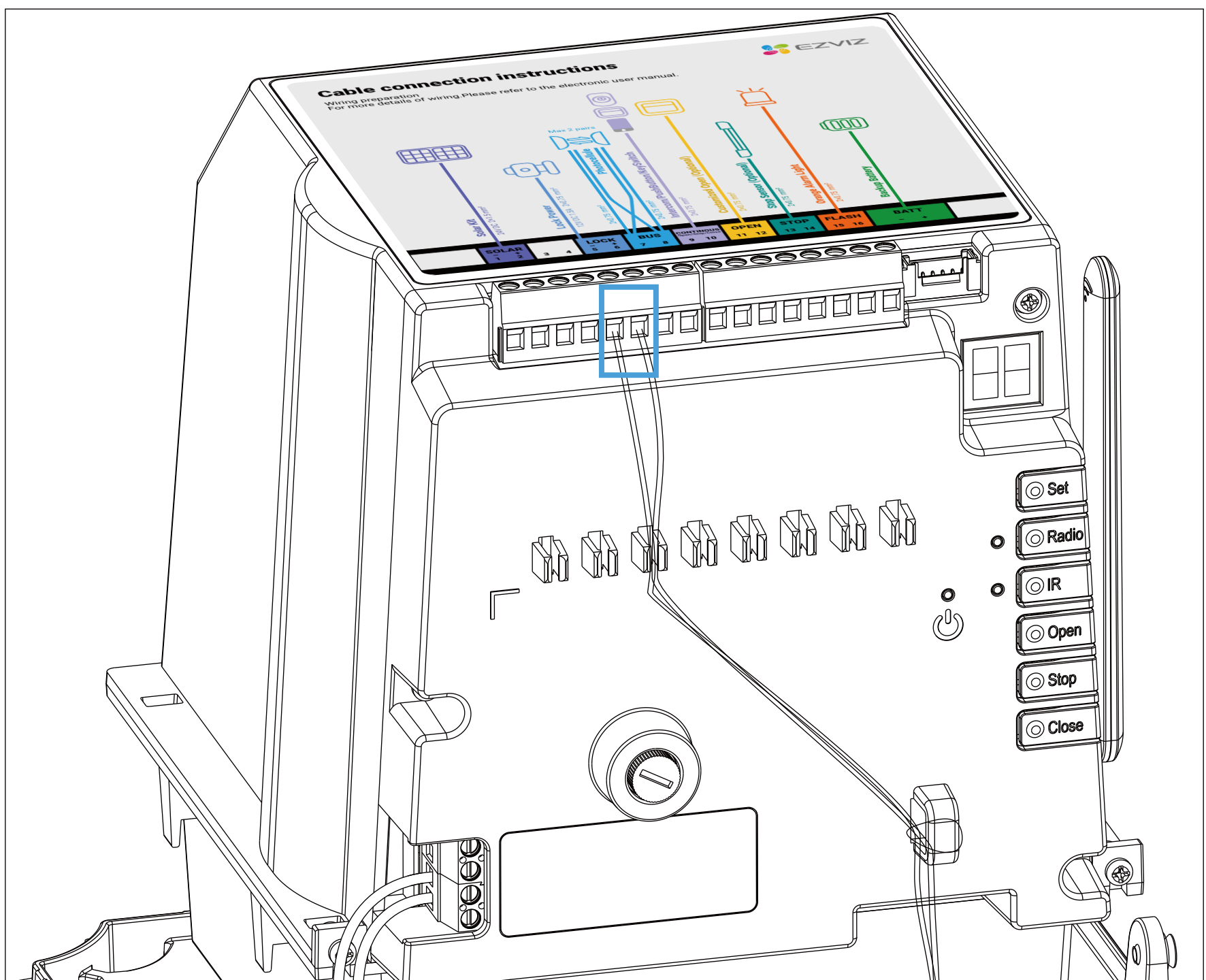

5. Connect to Area Lighting

The gate opener can also serve as a power supply to provide 230V AC power for your spotlight.

Connect the live wire of your spotlight to the "Lout" interface and the neutral wire to the "N" interface on the gate opener.



- **It is recommended that the power of the connected spotlight should not exceed 100 watts.**

After area lighting is connected, you can select how to turn on or off the spotlight. Go to the settings page of the gate opener (refer to [“2.2 Gate Opener Settings”](#)) and tap "Spotlight Setting":

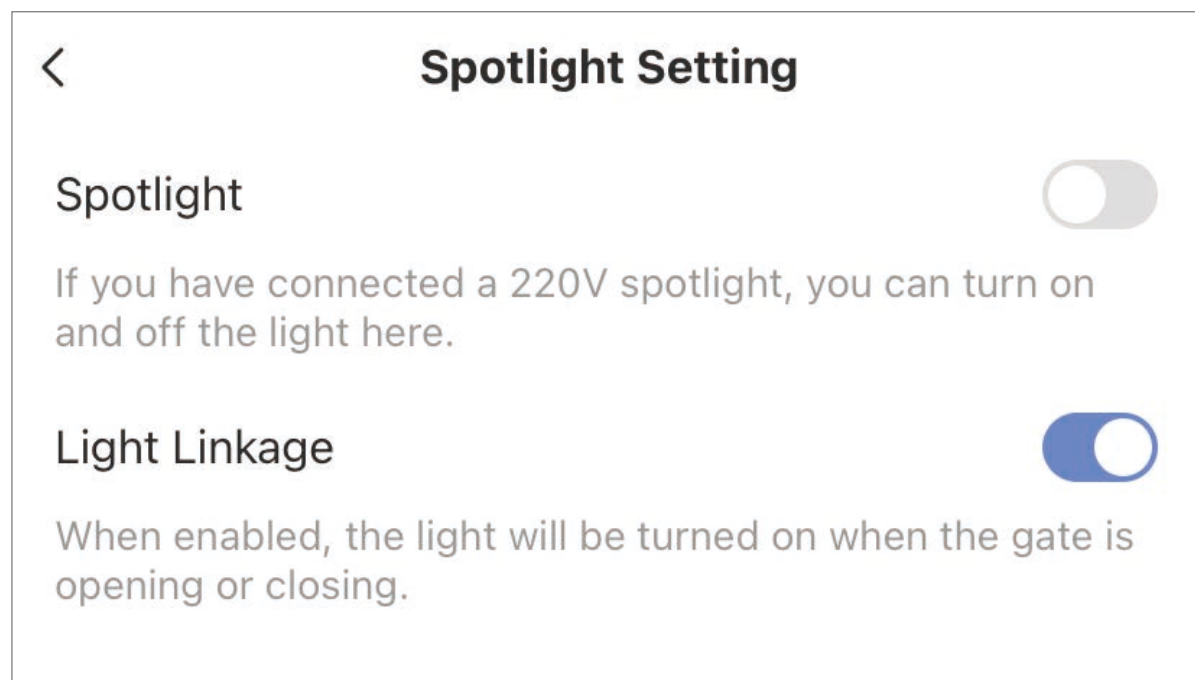

- **Spotlight**: You can manually turn on or off the light here.
- **Light Linkage** (visible only when the "Spotlight" switch is off): When the spotlight is turned off, you can also turn on "Light Linkage" so that the light will be automatically turned on when the gate is opening or closing. (The light will be automatically turned off 30 seconds after the gate stops.)

Preparatory Configuration

1. Wire Check

Check all wires according to the two instructional labels (as shown below) on the gate opener. Make sure there are no short-circuits.

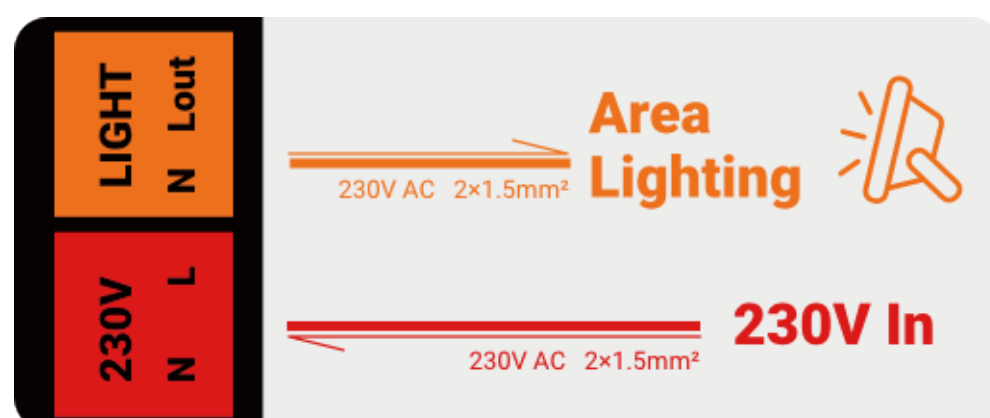
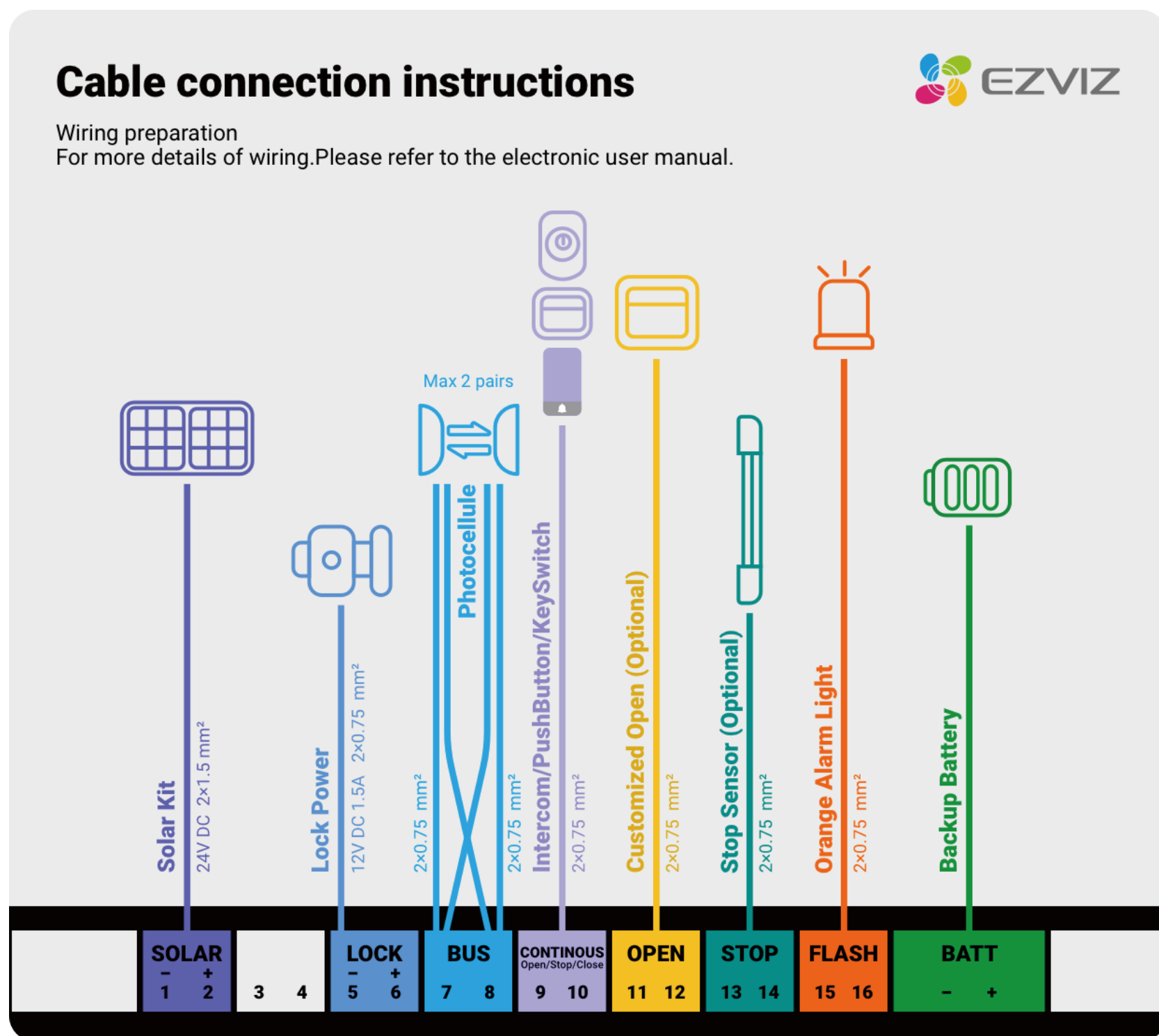

2. Power On the Gate Opener

i Before power-on, ensure that your wireless repeater has been added to the EZVIZ app and remains online, and terminal authorization is complete.

1. Close the circuit breaker used for the gate opener.

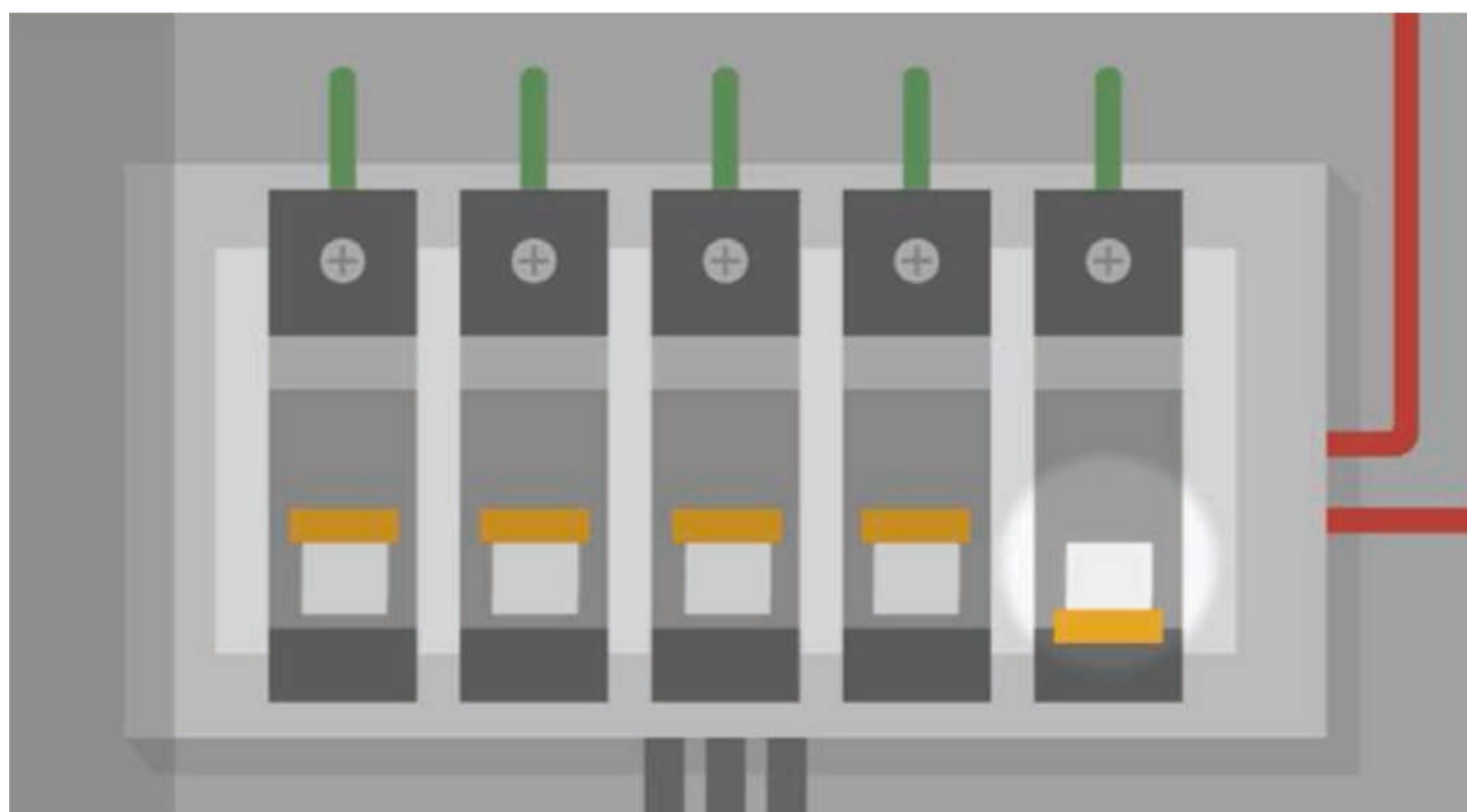

2. Check the following items to ensure that the gate opener has been successfully

powered on.

- The power indicator becomes solid red.
- The digital display tube lights up and shows "00", indicating the gate opener is starting up. After about 20 seconds, the digital display tube shows "--", indicating that the startup has finished.

3. After power-on, the gate opener starts a self-test and is then automatically added to your EZVIZ account (which may take a few minutes) based on communication with the wireless repeater. You can follow the wizard in the EZVIZ app to complete preparatory configuration.

3. Set the Gate-Opening Direction

Method 1 (recommended):

After the gate opener is added to your EZVIZ account, follow the wizard in the EZVIZ app to set the gate-opening direction.

- **The gate-opening direction refers to the direction to which your gate opens.**
- **If your gate opens to the left, select "Left Installation".**
- **If your gate opens to the right, select "Right Installation".**

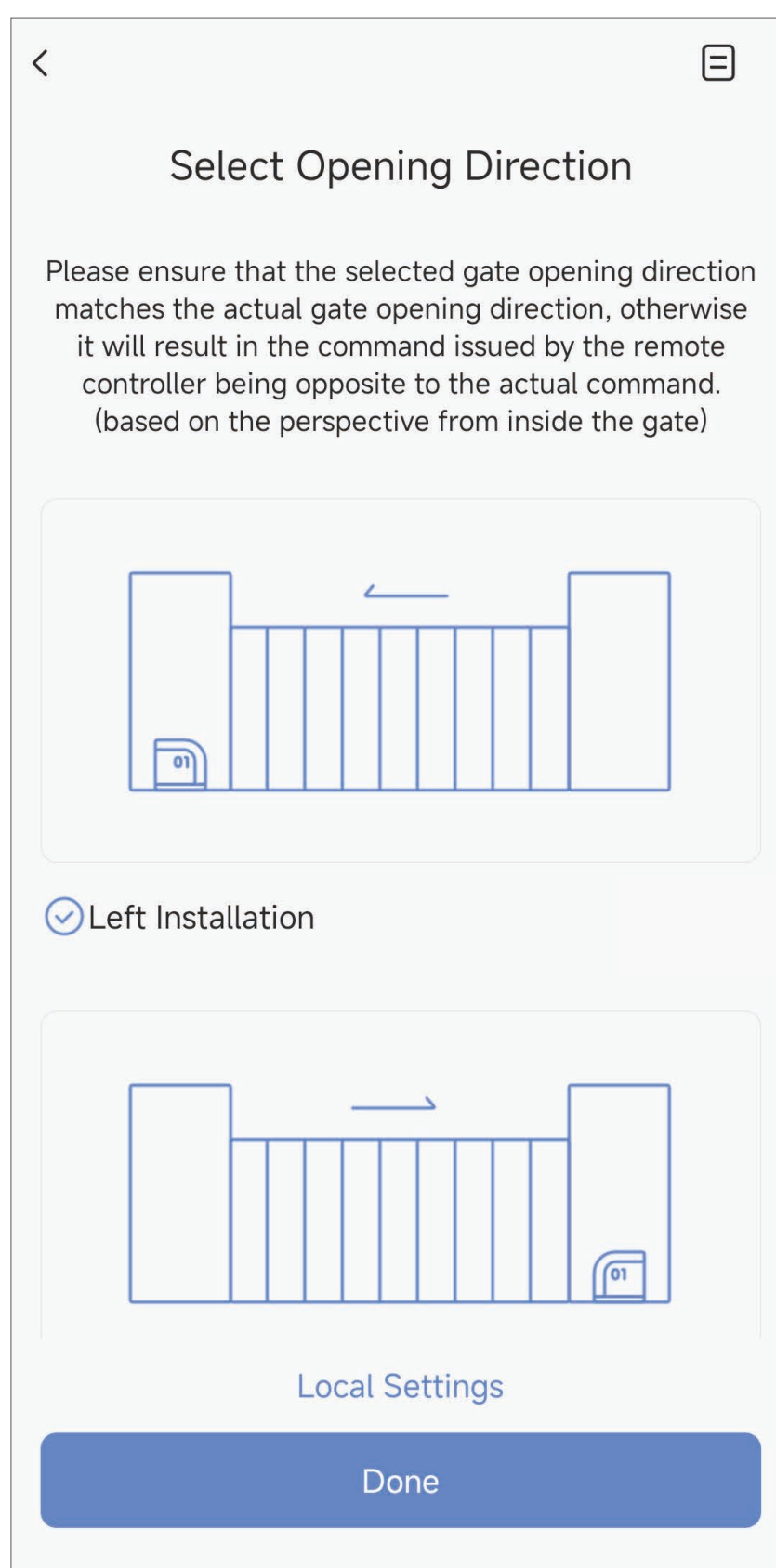

Method 2:

You can also set the gate-opening direction by using the physical buttons on the gate opener:

1. Press and hold the "Set" button for 3 seconds to enter the main menu.
2. Press the "Open" or "Close" button until "P2" is shown on the digital display tube.
3. Press the "Stop" button to enter the "P2" submenu. The current gate opening direction is displayed.

- **Refer to the table below for the correspondence between the code displayed and the gate opening direction.**

| Code Displayed | Gate Opening Direction |
|----------------|------------------------|
| 01 | Left |
| 02 | Right |

4. Press the "Open" or "Close" button until your desired gate opening direction is shown on the digital display tube.
5. Press the "Stop" button. The gate opener system goes back to the main menu.
6. Press and hold the "Set" button for 3 seconds to exit the main menu.

4. Add the Remote Controller

Basics of the remote controller

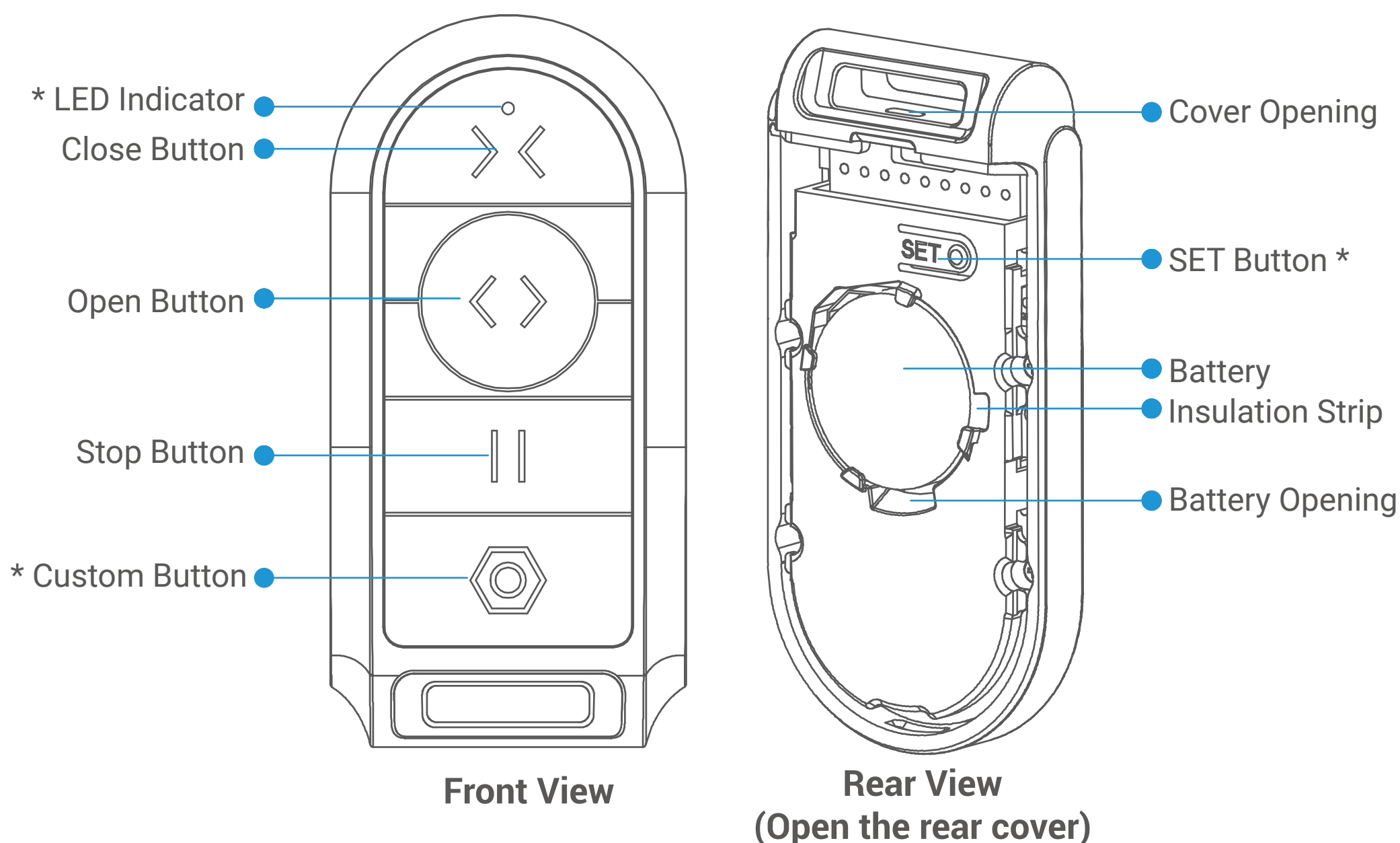

| Name | Description |
|---------------|--|
| LED Indicator | Fast-flashing red: Remote controller ready for pairing. |
| Custom Button | After pairing the remote controller with the gate opener, customize the function of this button in the gate opener's setting page in the EZVIZ App (Path: Settings > Lock/Unlock Settings > Customize Button Setting). |
| SET Button | Press and hold for 2 seconds: Remote controller ready for pairing. |

Pairing with the gate opener

i Before pairing the remote controller with the gate opener, please ensure that the gate opener has been added to the EZVIZ app.

1. Insert the pin (provided in the package) into the cover opening and press inward to unlock the cover.
2. Insert the pin into the gap between the remote controller and the cover and press down the pin to pry off the cover.

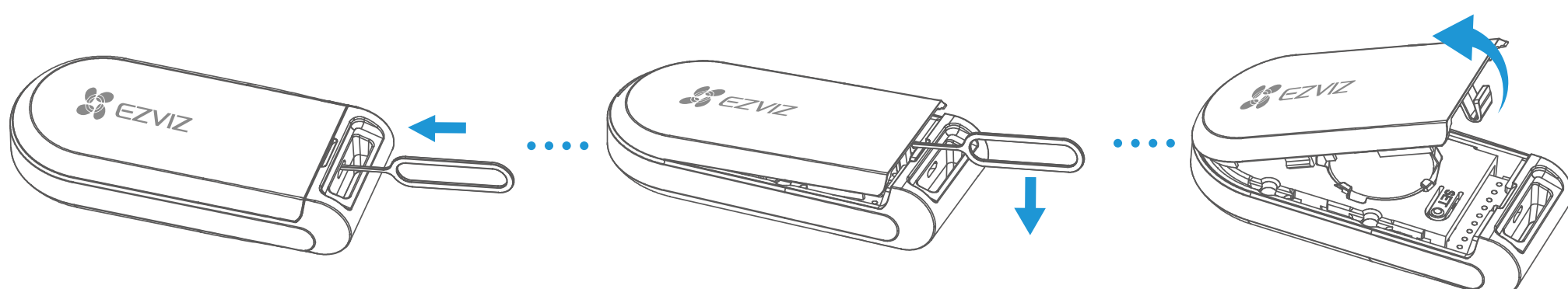

3. Remove the battery insulation strip.

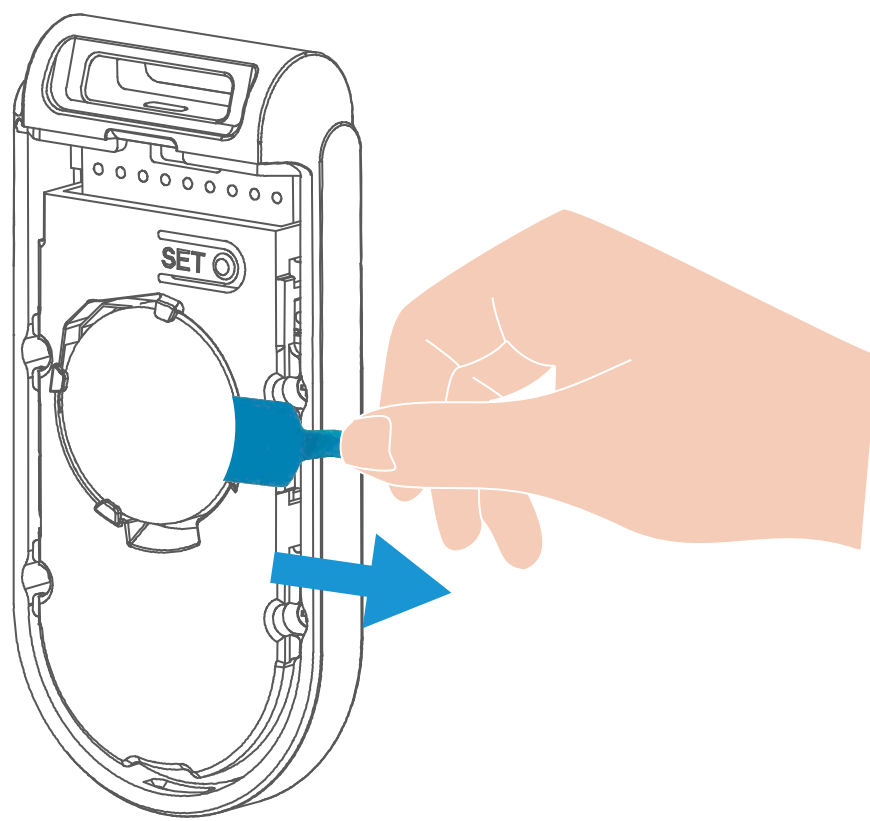

4. Pair the remote controller with the gate opener by using any of the following methods:

- It is recommended that the distance between the remote controller and the gate opener should be within 30 meters, with no more than 2 walls in between.
- Up to 8 remote controllers can be paired with one gate opener.

Method 1 (recommended):

- a. Follow the wizard in the EZVIZ app and tap "Start Adding".
- b. Within 60 seconds, press and hold the "SET" button on the remote controller for 2 seconds until the LED indicator of the remote controller becomes fast-flashing red.

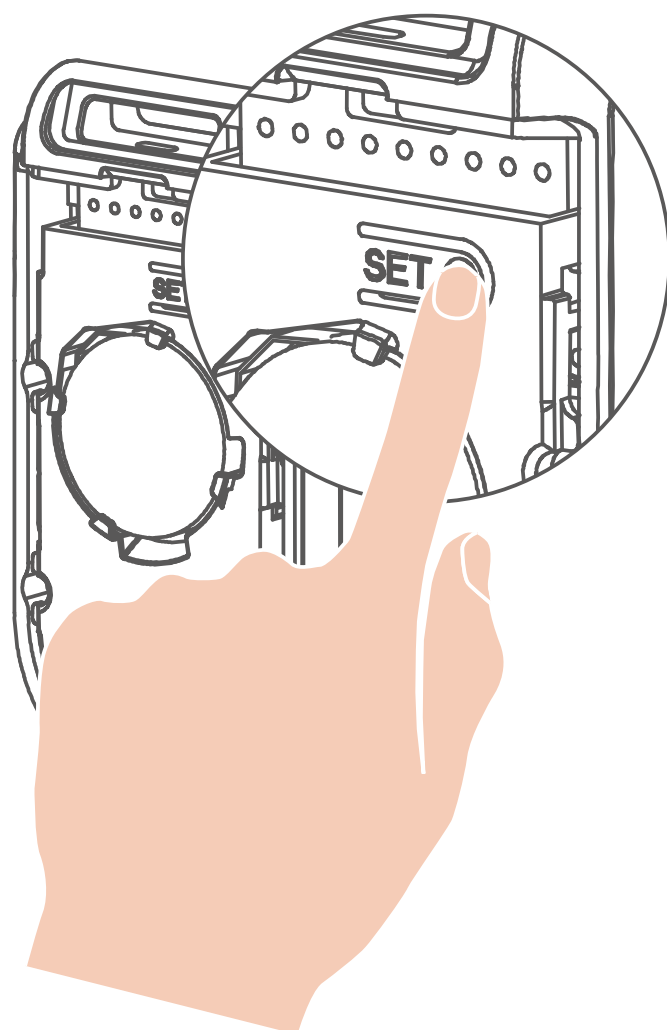
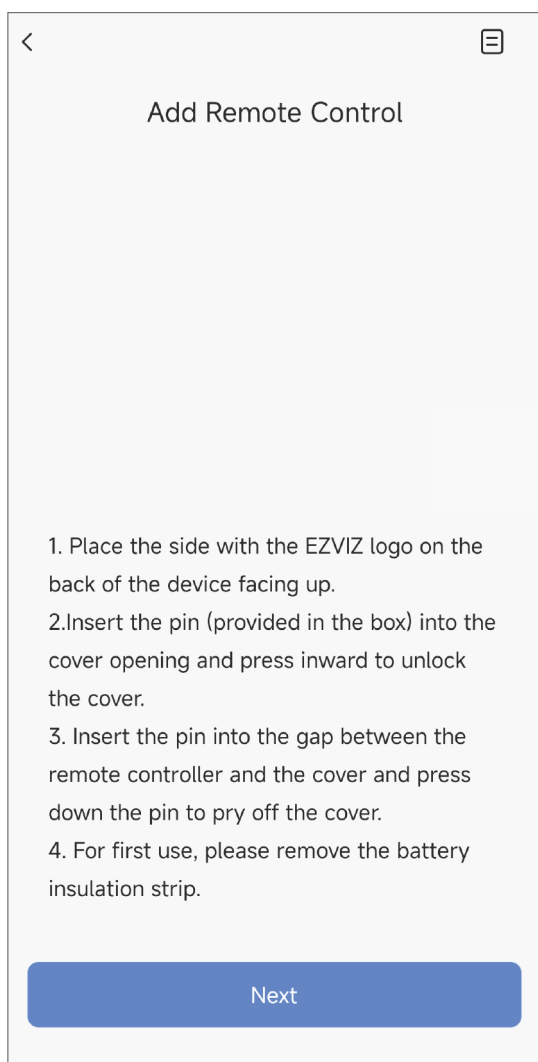

Method 2:

- a. Press and hold the "SET" button on the remote controller for 2 seconds until the LED indicator of the remote controller becomes fast-flashing red.
- b. Press the "Radio" button on the gate opener.

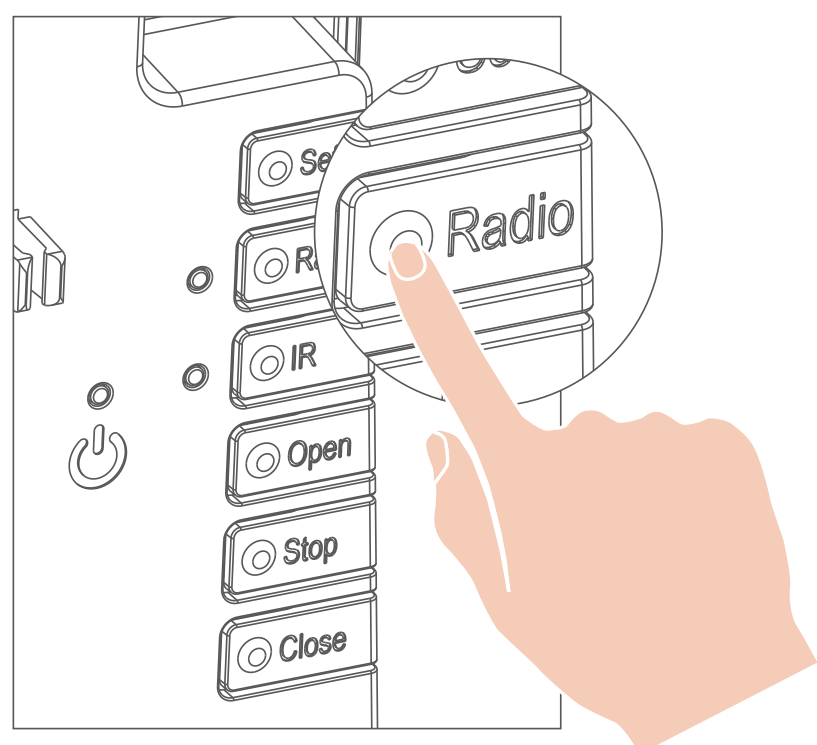
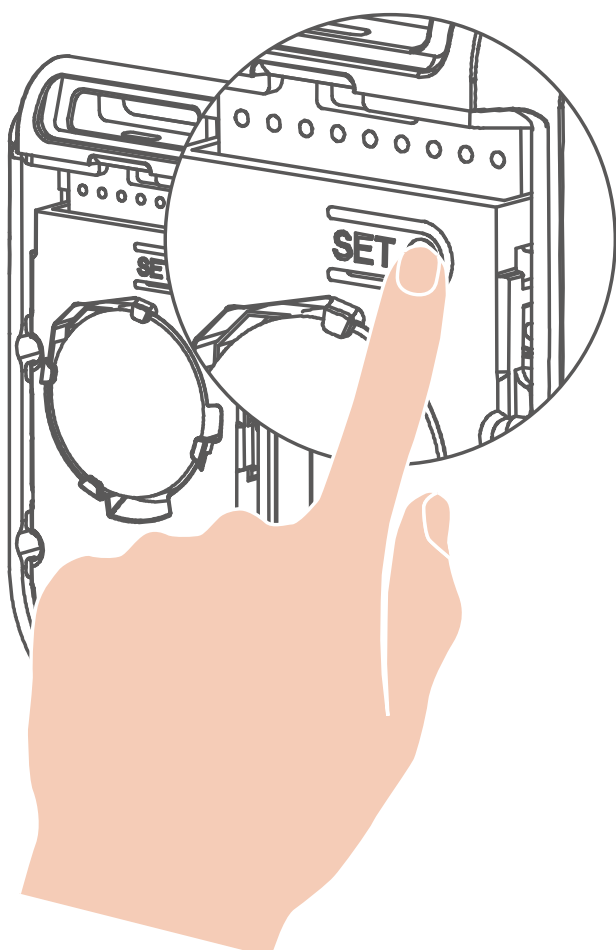

- When the LED indicator of the remote controller changes from solid red to fast-flashing red and then dimmed, it indicates that the remote controller has been successfully paired with the gate opener.



Battery Replacement

- i** Use CR2032 batteries for replacement.

When the range of the remote controller decreases significantly and the red light is dim, this means that the remote controller battery will soon be completely exhausted.

- Open the cover according to step 1 to step 2 of "Pairing with the gate opener".
- Insert the pin into the battery opening and press down the pin to pry off the battery.
- Install a new battery.
- Place the cover back on the remote controller.

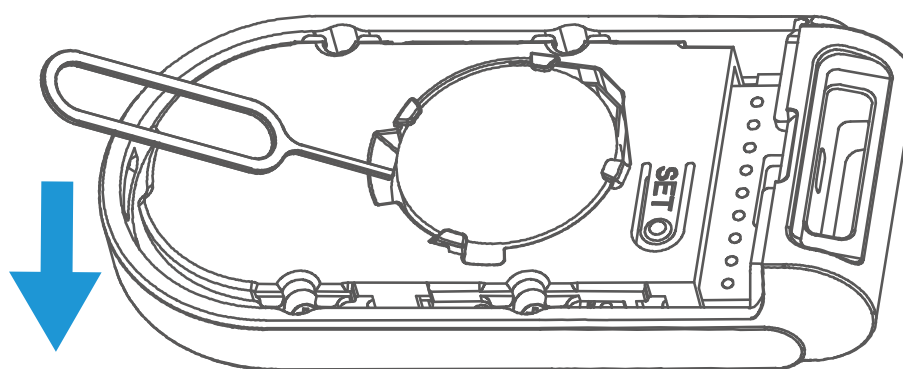

5. Test the Photocellules

- Press the "IR" button on the gate opener.

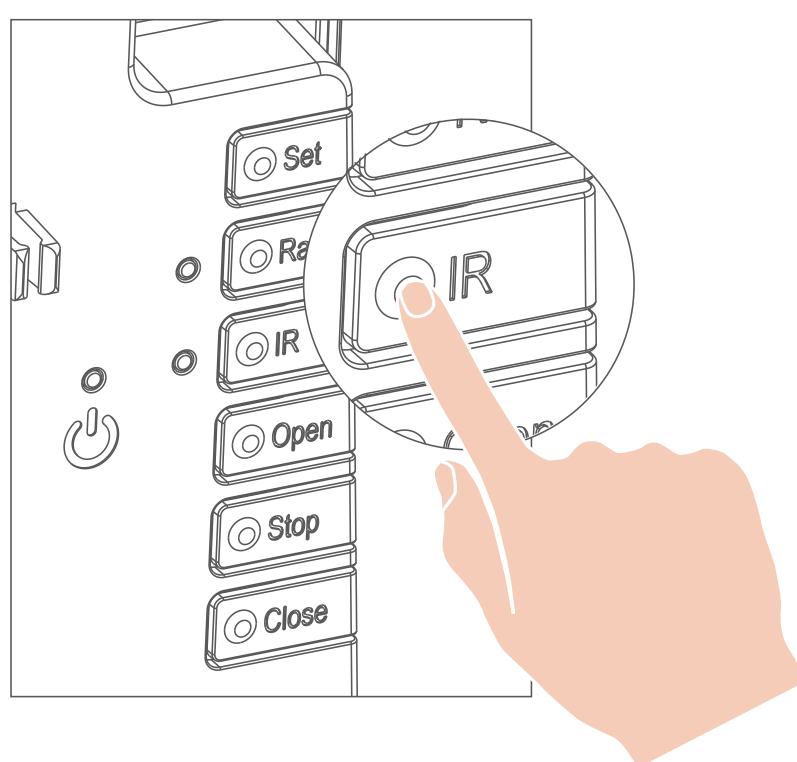

- The IR indicator becomes solid red, indicating that the gate opener has entered the infrared self-testing mode.
- Put an obstacle between the photocellules to check that the IR indicator becomes slow-flashing red.

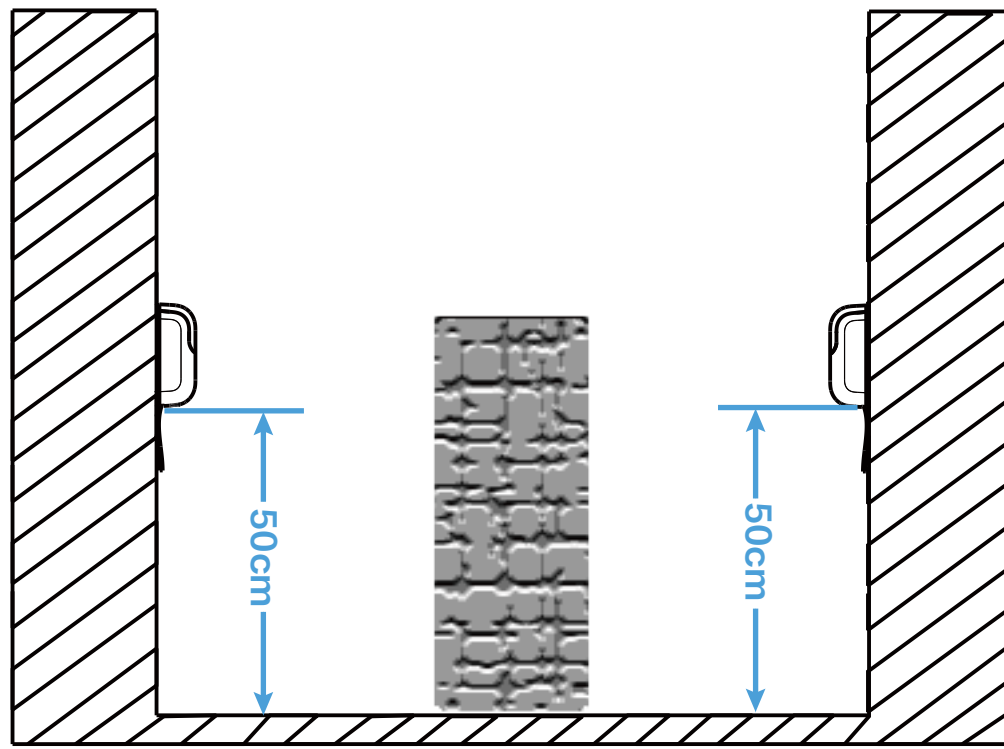

4. Remove the obstacle to check that the IR indicator returns to solid red.
5. Press the "IR" button again to exit the infrared self-testing mode.
6. The IR indicator dims, meaning that the gate opener has successfully exited the infrared self-testing mode.

6. Test Gate Opening/Closing

Use any of the following methods to test whether the gate opener can open and close the gate as expected.

Method 1 (recommended):

Follow the wizard in the EZVIZ app and tap the "Open", "Stop", and "Close" buttons to test whether the gate opener can perform functions properly.

During this process, the gate opener will learn and save the gate travel.

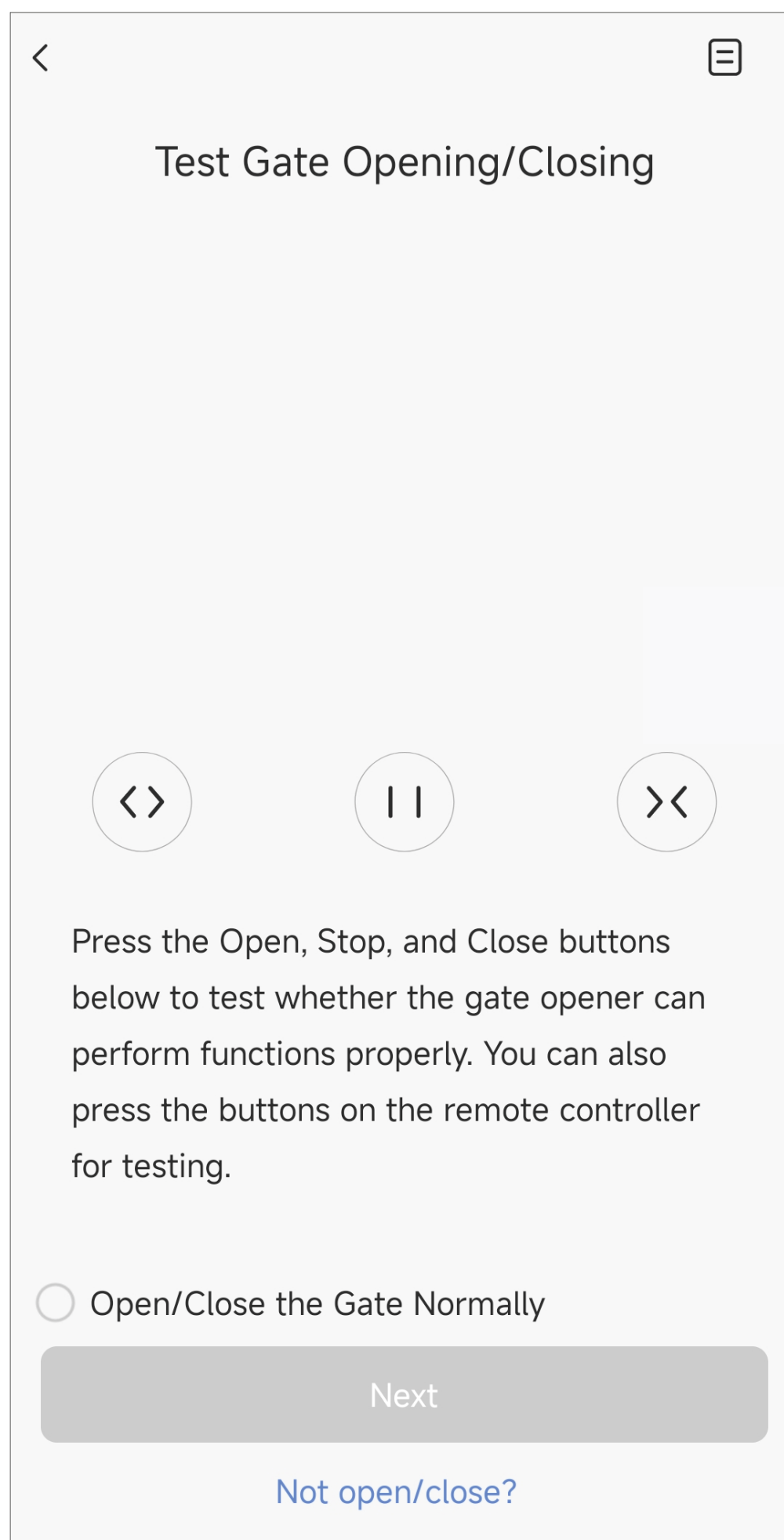

Method 2:

Press the Open, Close, and Stop buttons on the remote controller to check whether the gate can be opened, closed, and stopped as expected.

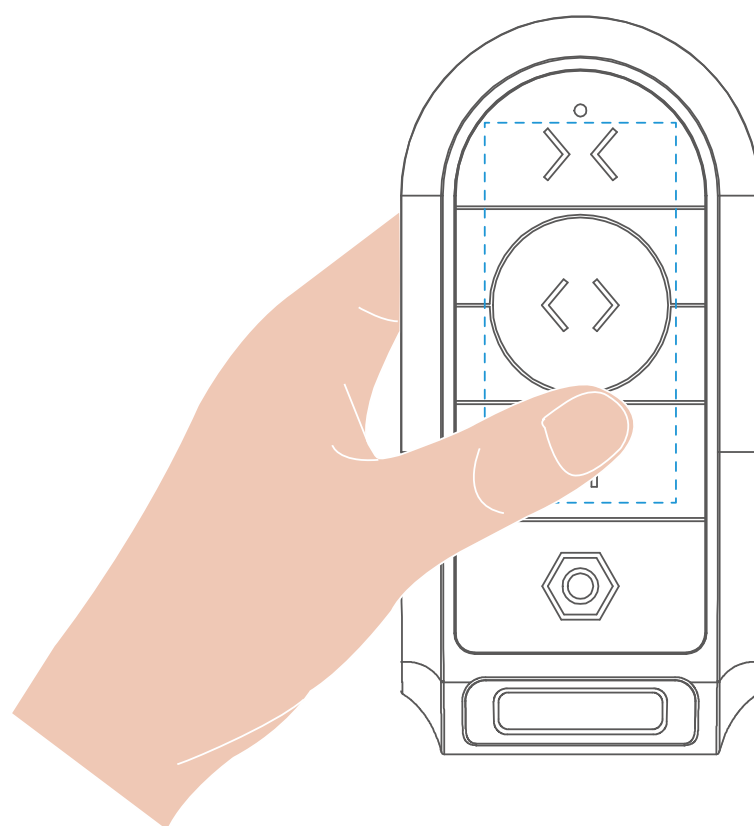

7. Install the Backup Battery

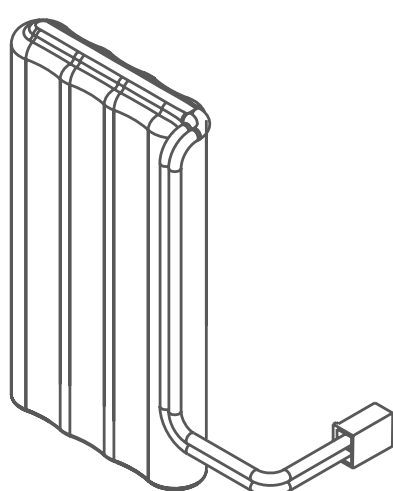

Backup Battery (×1)

1. Insert the backup battery into the battery chamber on the gate opener.
2. Connect the battery cable to the battery terminal.

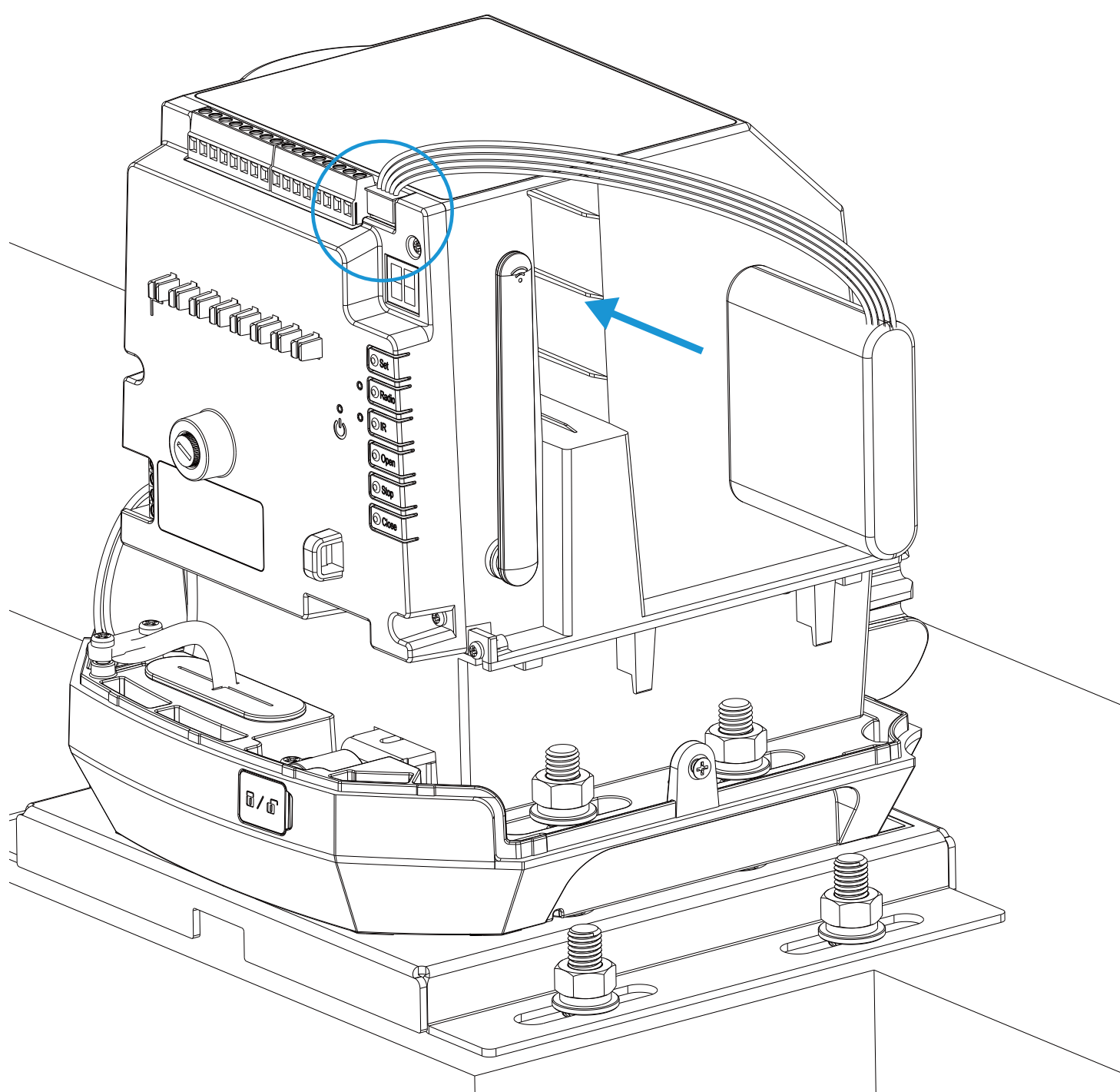

- ⚠ • Disposal of a battery into fire or a hot oven, or mechanically crushing or cutting of a battery can result in an explosion.
 - Leaving a battery in an extremely high temperature surrounding environment can result in an explosion or the leakage of flammable liquid or gas.
 - A battery subjected to extremely low air pressure may result in an explosion or the leakage of flammable liquid or gas.
- i** Buy EZVIZ batteries if you need any extra backup batteries.

8. Close the Gate Opener Cover

1. Put the gate opener cover back on the gate opener.
2. Use a screwdriver to tighten the screws back.
3. Close the waterproof plugs on both sides of the gate opener cover.

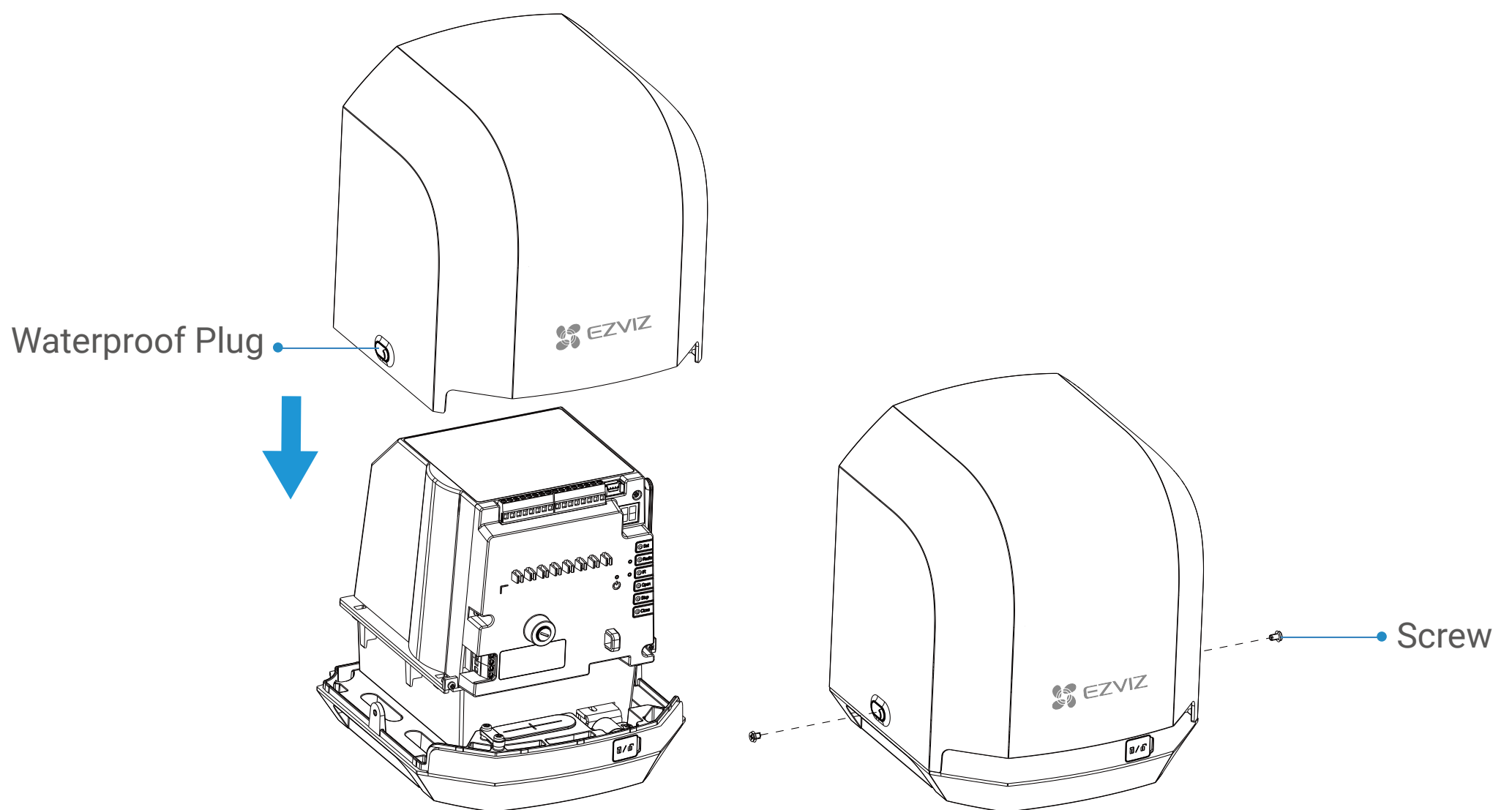

Settings

i The app interface may be different due to version update, and the interface of the app you installed on your phone shall prevail.

1. Wireless Repeater Management

1.1 Detail Page of Wireless Repeater

In the EZVIZ app, tap the device card of the wireless repeater. The detail page of the wireless repeater appears (as shown below).

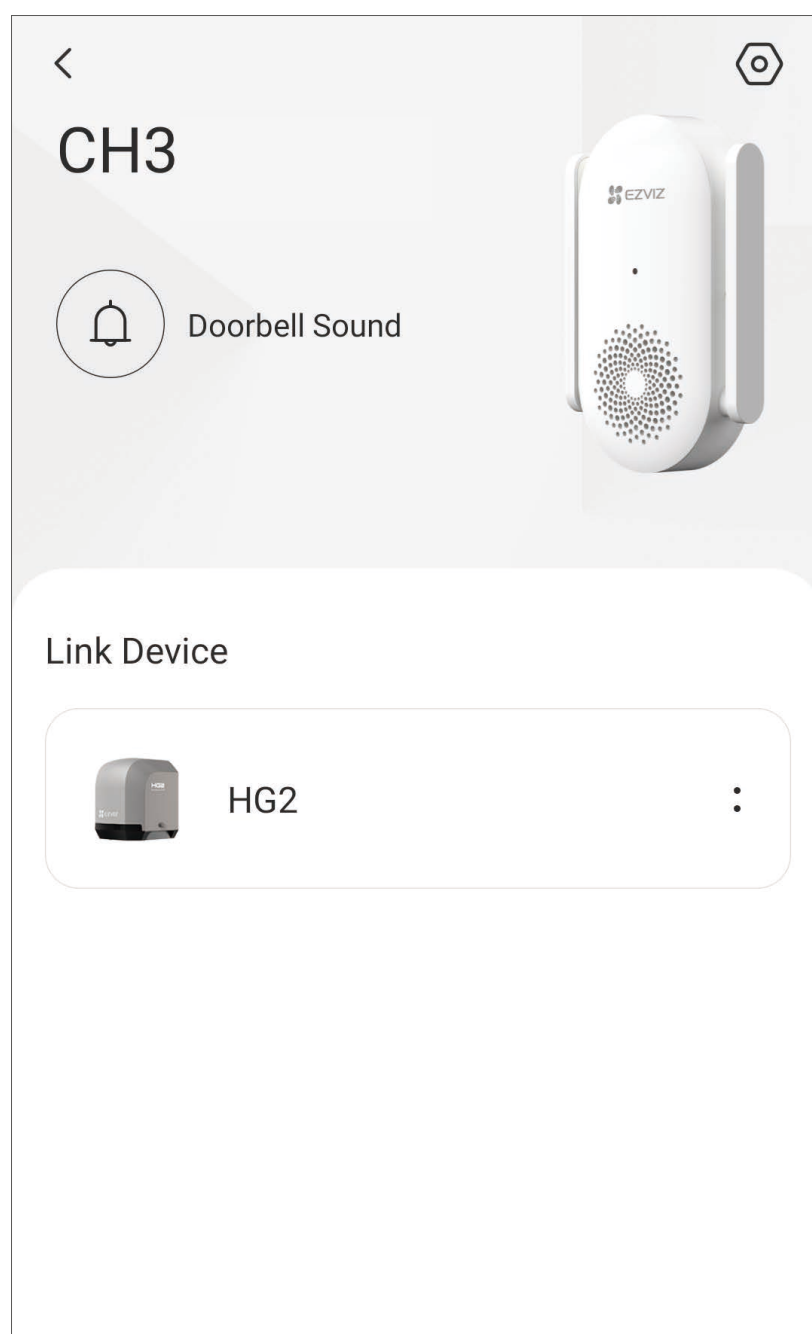

| Icon | Description |
|------|---|
| | Settings. View or change the settings of the wireless repeater. |
| | Mute. Tap to mute the speaker of the wireless repeater. |

i After power-on, the gate opener will be automatically linked with the wireless repeater, added to your EZVIZ account, and displayed in the "Link Device" area on the detail page of the wireless repeater.

1.2 Wireless Repeater Settings

On the detail page of the wireless repeater, tap the icon to enter the settings page. You can perform the following settings as needed.

| Setting | Description |
|----------------|--|
| Name | View or tap to customize the name of your wireless repeater here. |
| Audio Settings | You can adjust the volume of the reminder sound and set the doorbell sound DND (Do Not Disturb) scheme here. |
| Light Settings | You can turn on or off the LED indicator here. |

| Setting | Description |
|--------------------|---|
| Network Settings | You can view the name of the currently connected network or tap to change to another Wi-Fi network. |
| Device Information | You can see the device information here, including the user guide. |
| More | You can authorize terminals to add them to your EZVIZ account. |
| Delete Device | Tap to delete the wireless repeater from the EZVIZ app. |

1.3 Binding a New Wireless Repeater

i This operation is only necessary when setting up a newly purchased wireless repeater after your original one becomes unusable. If you have only relocated your gate opener, simply reset the wireless repeater (refer to the description of the RESET button in ["Basics"](#)).

You can bind a new wireless repeater in two ways:

Method 1 (recommended): Binding a new wireless repeater in the EZVIZ app

1. Plug in the new wireless repeater and add it to your EZVIZ account (for operation details, please refer to ["5. Add Wireless Repeater to Your EZVIZ Account"](#)).
2. Go to the detail page of the wireless repeater.
3. Tap the binding entry to enter the binding page.
4. Scan the QR code on the gate opener.
5. Press and hold the "IR" button on the gate opener for 5 seconds. The digital display tube shows "22". The gate opener enters the binding mode (effective duration: 300 seconds).

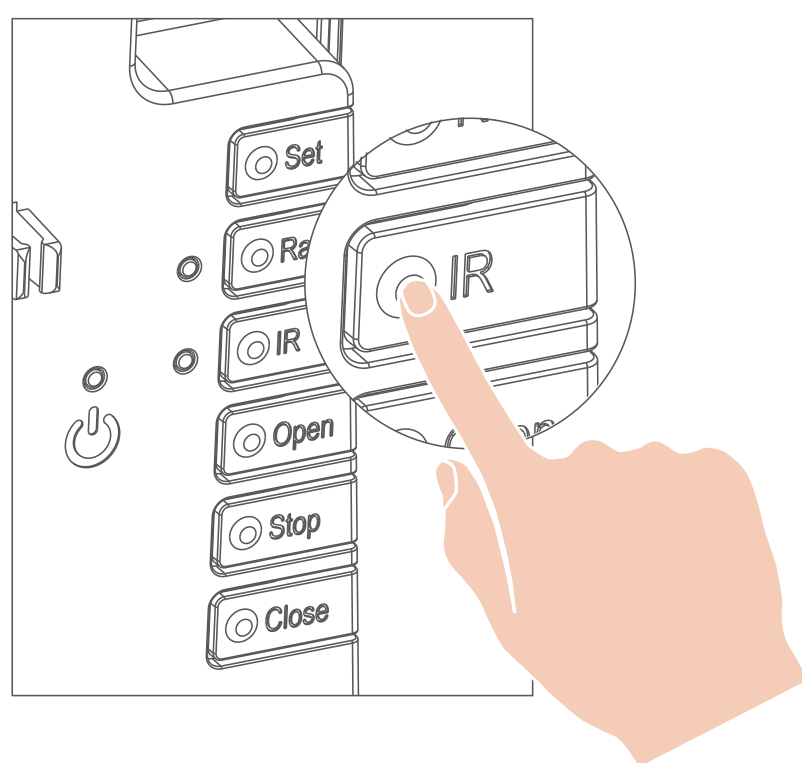

The digital display tube of the gate opener returns to normal. The gate opener has been linked with the wireless repeater and added to your EZVIZ account.

Method 2: Binding a new wireless repeater on the gate opener

1. Plug in the new wireless repeater and add it to your EZVIZ account (for operation details, please refer to ["5. Add Wireless Repeater to Your EZVIZ Account"](#)).
2. Press and hold the RESET button on the wireless repeater for 10 seconds until the LED indicator becomes fast-flashing red and blue alternately, which indicates that the wireless repeater is now ready for re-binding.

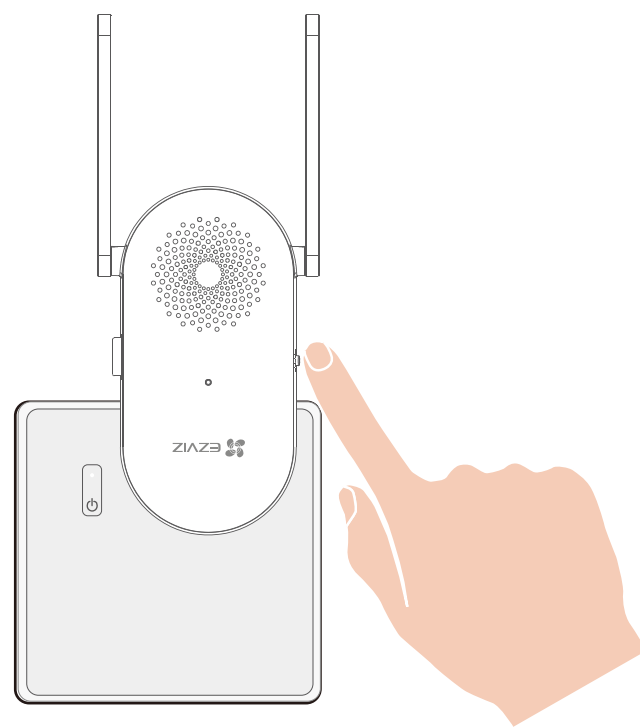

3. Press and hold the "IR" button on the gate opener for 5 seconds. The digital display tube shows "22". The gate opener enters the binding mode (effective duration: 300 seconds).

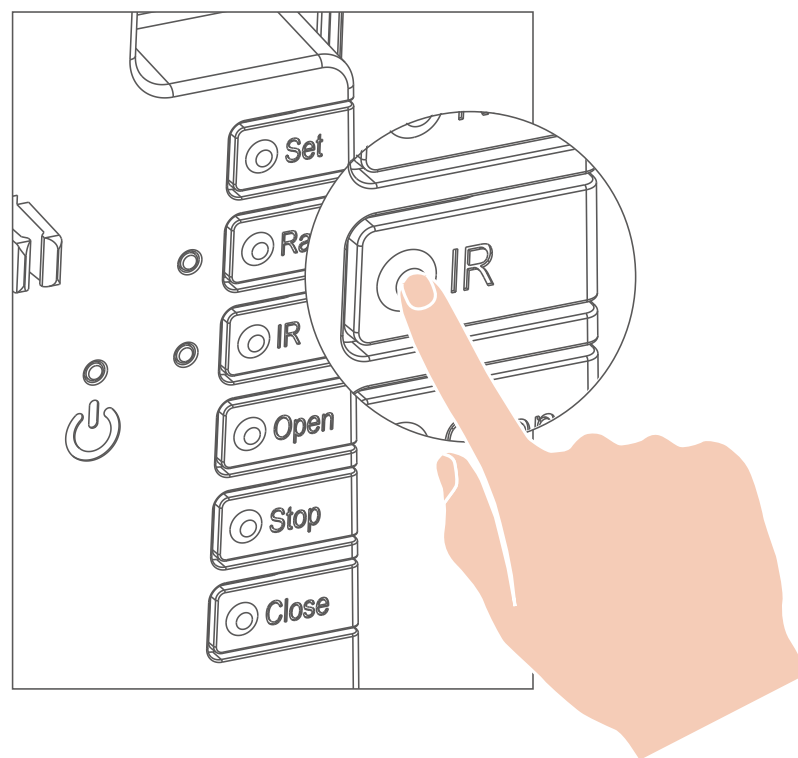

4. When the gate opener receives the identity information of the wireless repeater, the digital display tube shows "22" in fast-flashing mode.
5. Press the "IR" button on the gate opener. The identity information of the wireless repeater is saved on the gate opener, and the gate opener returns a binding success message to the wireless repeater.

The gate opener exits the binding mode and the digital display tube returns to normal. The gate opener has been linked with the wireless repeater and added to your EZVIZ account.

2. Gate Opener Management

2.1 Detail Page of Gate Opener

In the EZVIZ app, tap the device card of the gate opener. The detail page of the gate opener appears (as shown below).

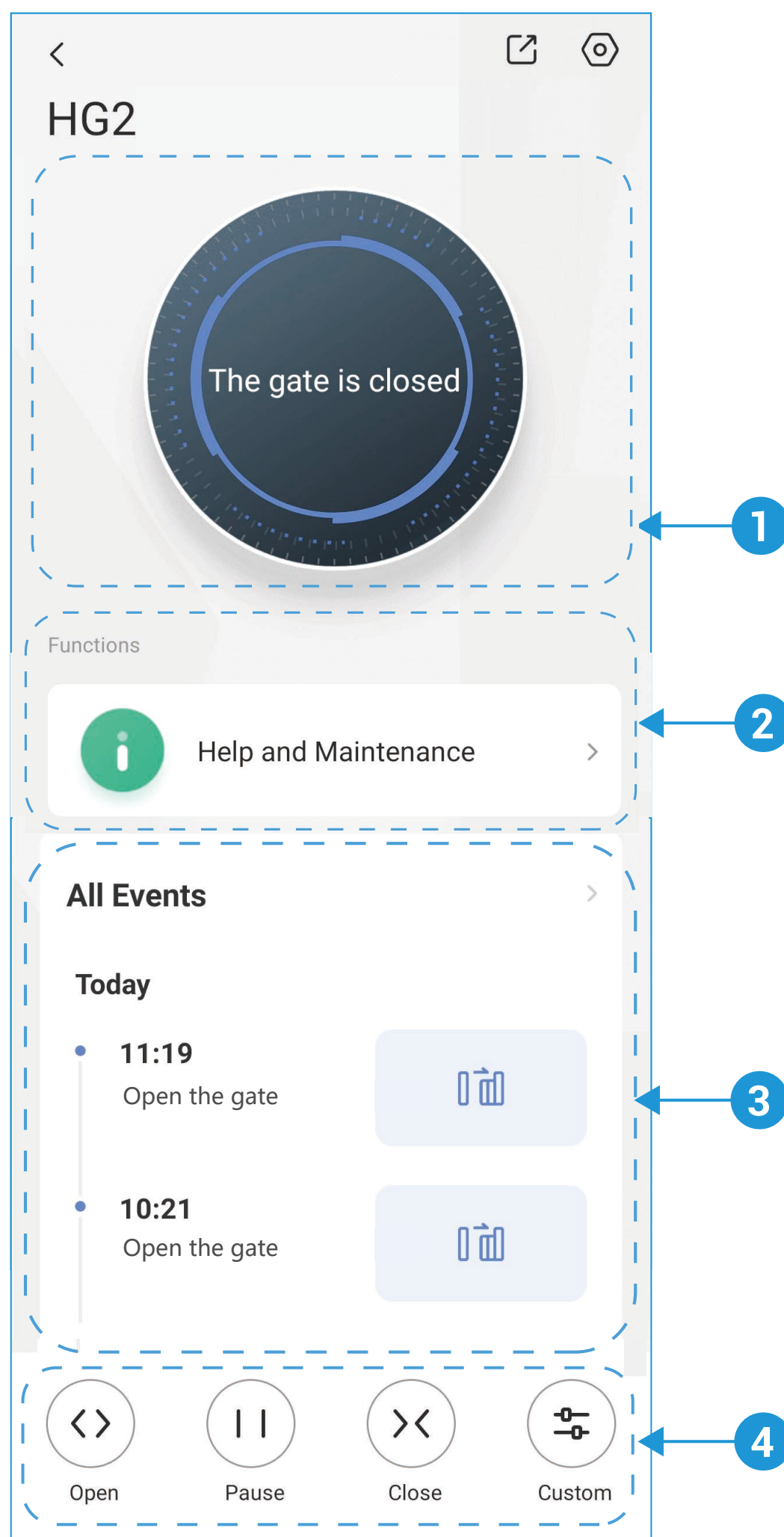

| No. | Area | Description |
|-----|---------------|--|
| 1 | Status | Displays the current state of the gate and error code (if any). |
| 2 | Functions | Provides the entry to Help and Maintenance. |
| 3 | Event Records | Displays all event records. |
| 4 | Buttons | Provides four operation buttons for you to control the gate movement in the EZVIZ app. |

| Icon | Description |
|------|--|
| | Share. Share your device with anyone you want. |
| | Settings. View or change the settings of the gate opener. |
| | Help & Maintenance. Tap to obtain the installation guide, fault assistance, and FAQ. |
| | Open. Tap to open the gate. |
| | Stop. Tap to stop the gate. |

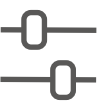
| Icon | Description |
|---|--|
|  | Close. Tap to close the gate. |
|  | Custom. Tap to open the gate in custom mode. The gate will be 1/4 Open, 1/2 Open, 3.4 Open, or Fully Open (according to the custom mode you have set). |

- i** If the gate opener is offline, you can connect to the gate opener via the Bluetooth function of your mobile phone to control gate movement. Follow the steps below:
1. Turn on the Bluetooth function on your mobile phone.
 2. On the detail page of the gate opener, tap the Bluetooth icon and then confirm to start pairing.
 3. Enter the verification code (which you can find in the QR code label of the gate opener).
 4. Wait until the gate opener is connected, and then you can control gate movement by tapping the buttons.

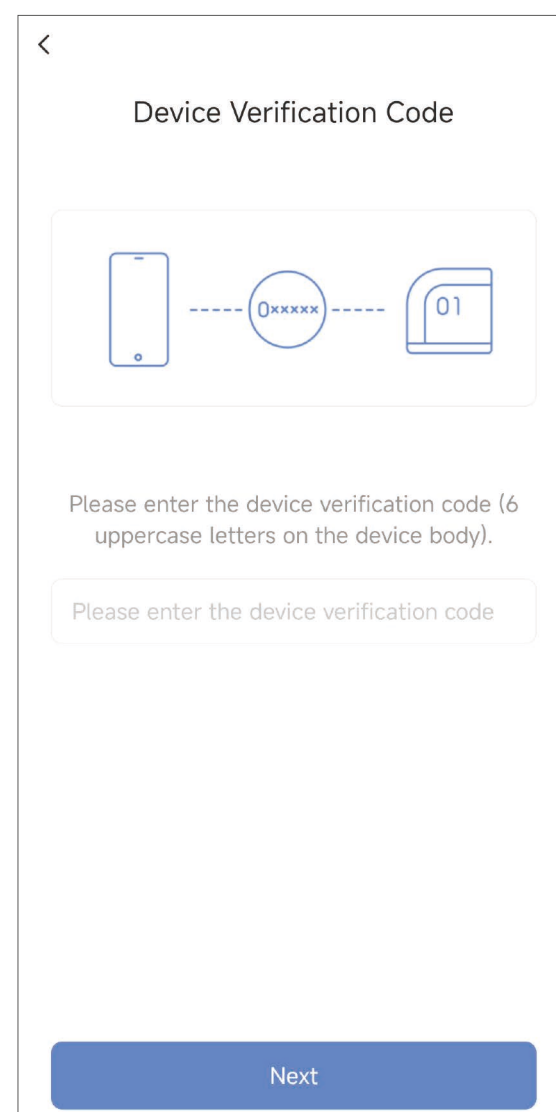
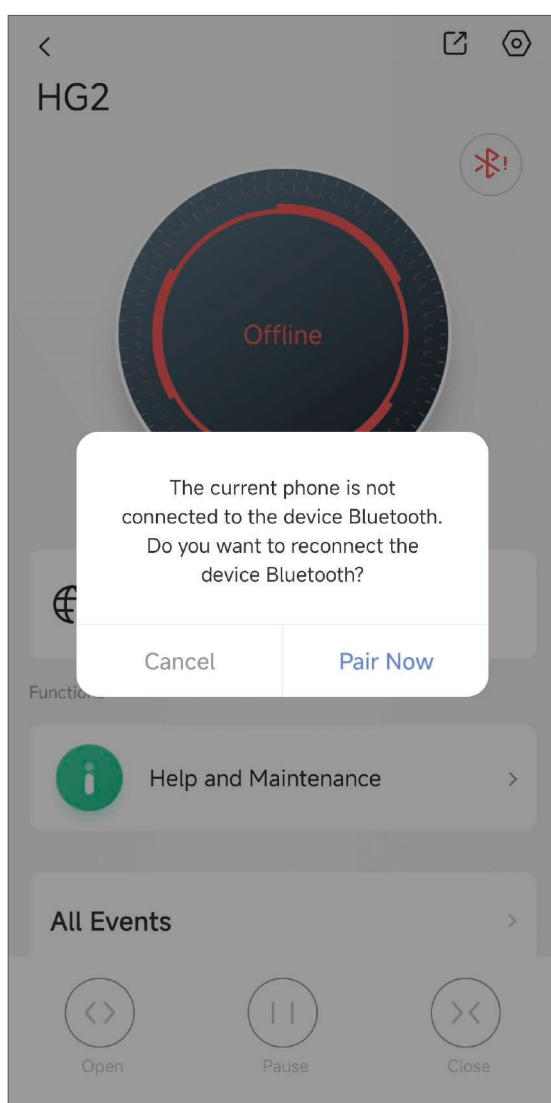

2.2 Gate Opener Settings

Entry 1:

On the detail page of the gate opener, tap the  icon in the upper-right corner to enter the settings page.

Entry 2:

On the detail page of the wireless repeater, tap the device card of the gate opener and select "Gate Opener Settings" to enter the settings page of the gate opener.

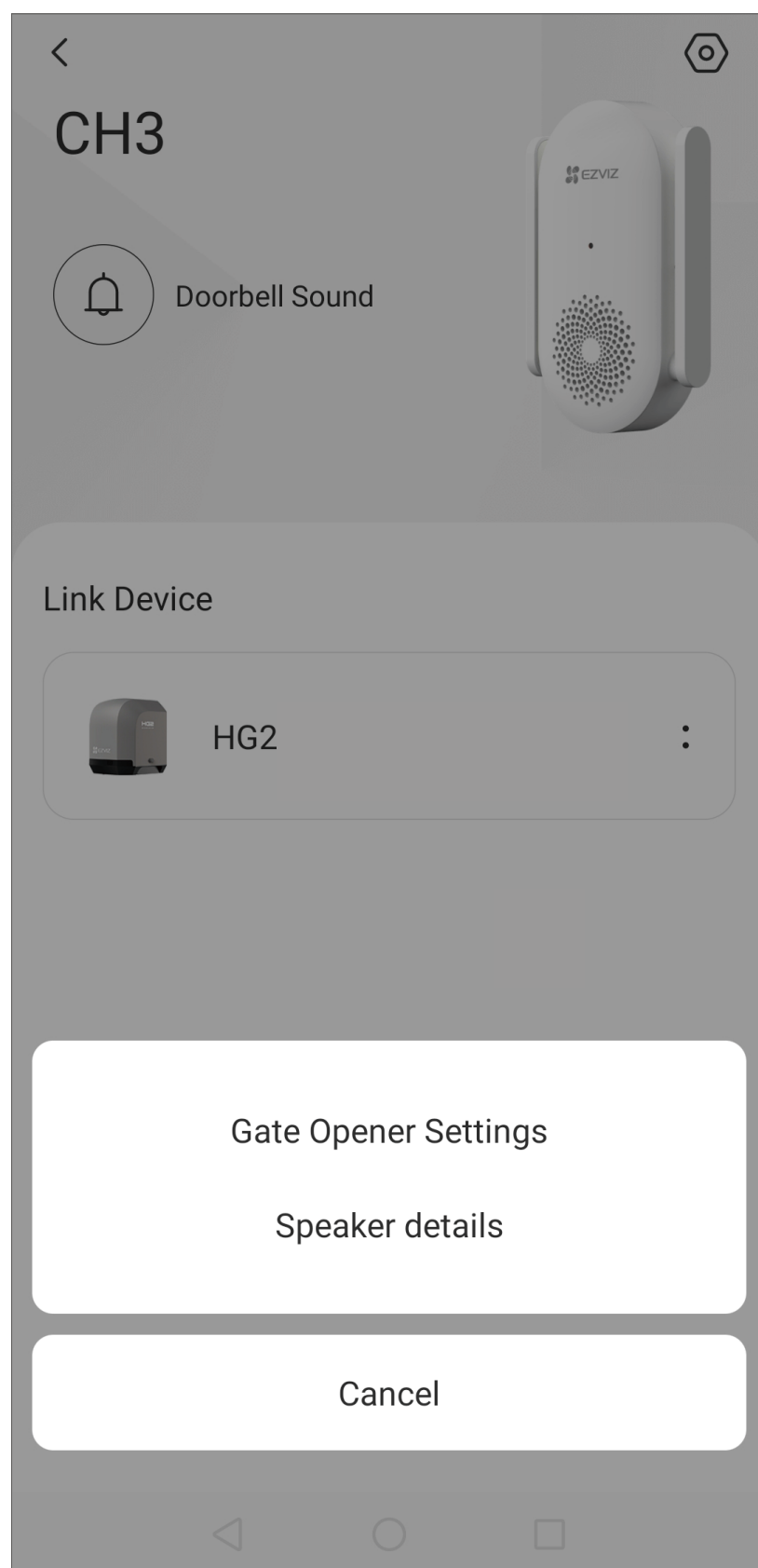

On the settings page of the gate opener, you can perform the following settings as needed.

| Setting | Description |
|-------------------------------|---|
| Gate Opening/Closing Settings | Configure the gate opening/closing speed, resistance rebound sensitivity, auto closing, opening direction, custom button setting, and travel re-learning. |
| Accessory Management | Manage accessories such as remote controllers. |
| Alarm Light Volume | Turn on or off the sound of the alarm light. |
| Alarm Light Brightness | Turn on or off the flashing light of the alarm light. |
| Spotlight Setting | If you have connected a spotlight to the gate opener, you can turn on or off the spotlight here. |
| Message Notification | You can manage the device message and EZVIZ app notification. |
| Network Settings | Check the strength of the signal between the gate opener and the wireless repeater here.  The position of the wireless repeater can be adjusted according to the signal strength to ensure the stable network status of the gate opener. |
| Device Information | You can see the device information here, including the user guide. |

| Setting | Description |
|----------------|--|
| Share Device | You can share the device to your family member or guest. |
| Restart Device | Tap to restart the gate opener. |
| Delete Device | Tap to delete the gate opener from the EZVIZ app. |

Set the gate opening/closing speed

If you think the gate opening/closing speed is too fast or slow, you can adjust the speed in two ways:

Method 1 (recommended):

1. On the settings page of the gate opener, tap "Gate Opening/Closing Settings".
2. Based on your actual environment, select a desired gate opening/closing speed by adjusting the slider.

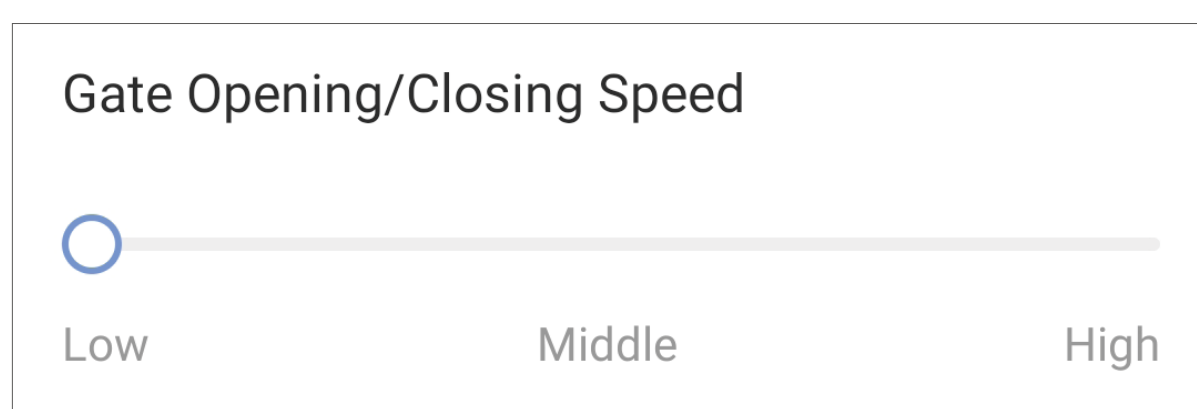

Method 2:

1. Open the cover of the gate opener.
2. Press and hold the Set button for 3 seconds to enter the main menu. "P1" is displayed on the digital display tube, which means you are currently configuring the gate opening/closing speed.

i Refer to the table below for correspondence between the code displayed and the submenu.

| Code Displayed | Submenu |
|----------------|--------------------------------|
| P1 | Gate opening/closing speed |
| P2 | Gate opening direction |
| P3 | Resistance rebound sensitivity |

3. Press the Stop button to enter the "P1" submenu. The current speed level is displayed.

i Refer to the table below for correspondence between the code displayed and the speed level.

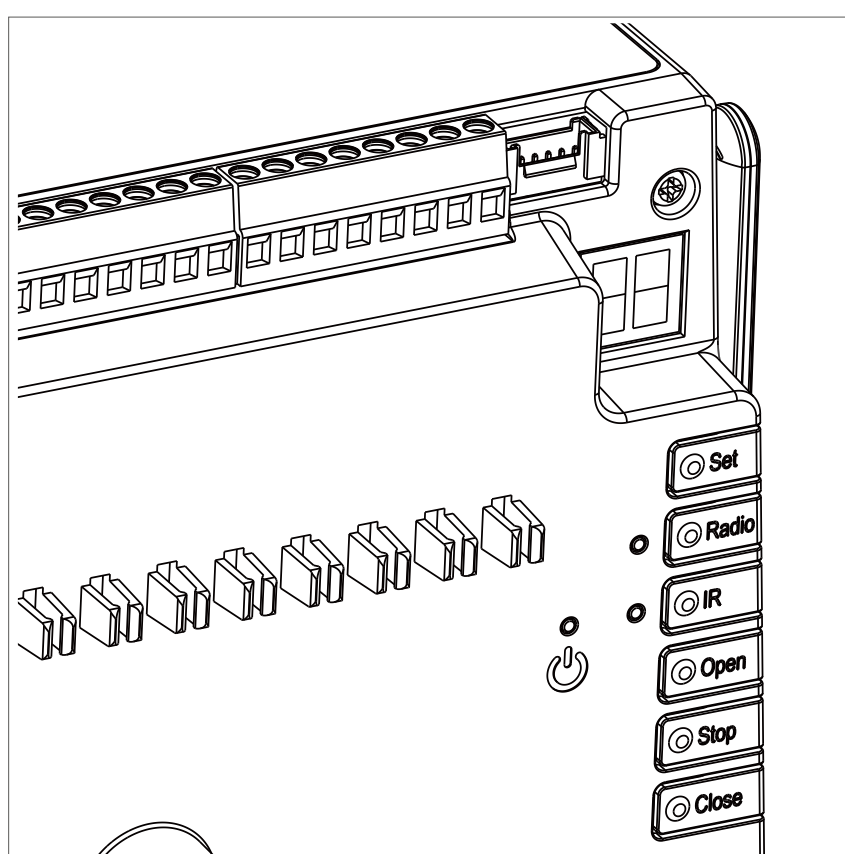

| Code Displayed | Speed Level |
|----------------|-------------|
| 01 | Low |
| 02 | Middle |

| Code Displayed | Speed Level |
|----------------|-------------|
| 03 | High |

- Press the Open or Close button until your desired speed level is displayed on the digital display tube.
- Press the Stop button. The gate opener system goes back to the main menu.

Set the resistance rebound sensitivity

It is recommended to adjust the resistance rebound sensitivity based on your actual environment. For example, if there is no obstacle along the gate travel, but still an obstacle is detected, you can adjust the sensitivity level lower. You can adjust the resistance rebound sensitivity in two ways:

Method 1 (recommended):

- On the settings page of the gate opener, tap "Gate Opening/Closing Settings".
- Based on your actual environment, select a desired resistance rebound sensitivity level by adjusting the slider.

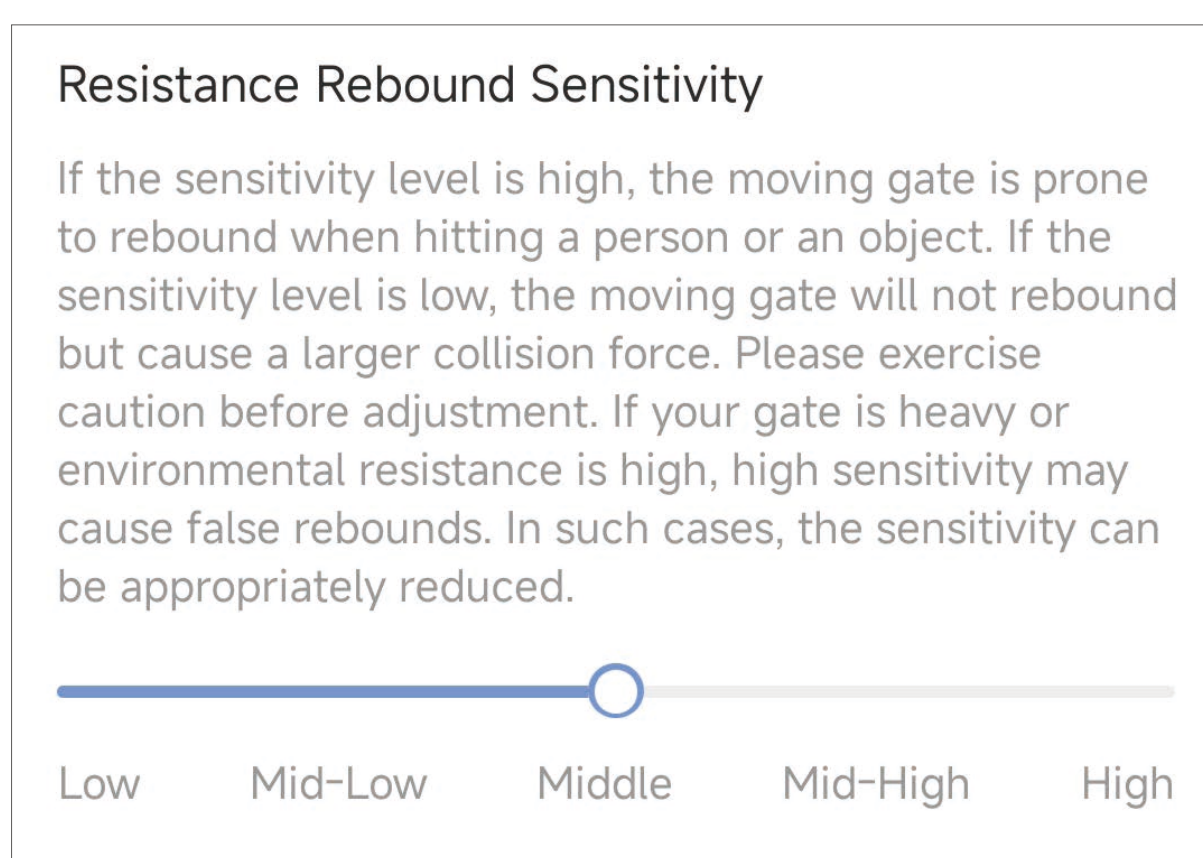

Method 2:

- Open the cover of the gate opener.
- Press and hold the Set button for 3 seconds to enter the main menu.
- Press the Open or Close button until "P3" is displayed on the digital display tube.
- Press the Stop button to enter the "P3" submenu. The current sensitivity level is displayed.

i Refer to the table below for the correspondence between the code displayed and the gate opening direction.

| Code Displayed | Resistance Rebound Sensitivity |
|----------------|--------------------------------|
| 01 | Low |
| 02 | Mid-Low |
| 03 | Middle |
| 04 | Mid-High |
| 05 | High |

- Press the Open or Close button until your desired sensitivity level is displayed on the digital display tube.
- Press the Stop button. The gate opener system goes back to the main menu.

i If the resistance in your gate installation environment is large or your gate is heavy, it is recommended to set a low gate speed and a high resistance rebound sensitivity level and fix a force limiter at both the primary and secondary edges of the gate frame.

Set auto closing

For security reasons, this gate opener provides the auto closing function to prevent any potential security threat caused by forgetting to close the gate. When this function is enabled, the gate can automatically close after the specified period of time if the gate receives no control signal within that time.

1. On the settings page of the gate opener, tap "Gate Opening/Closing Settings" > "Auto Closing".
2. Turn on the "Auto Closing" switch to enable the function.
3. Select an interval for auto closing.

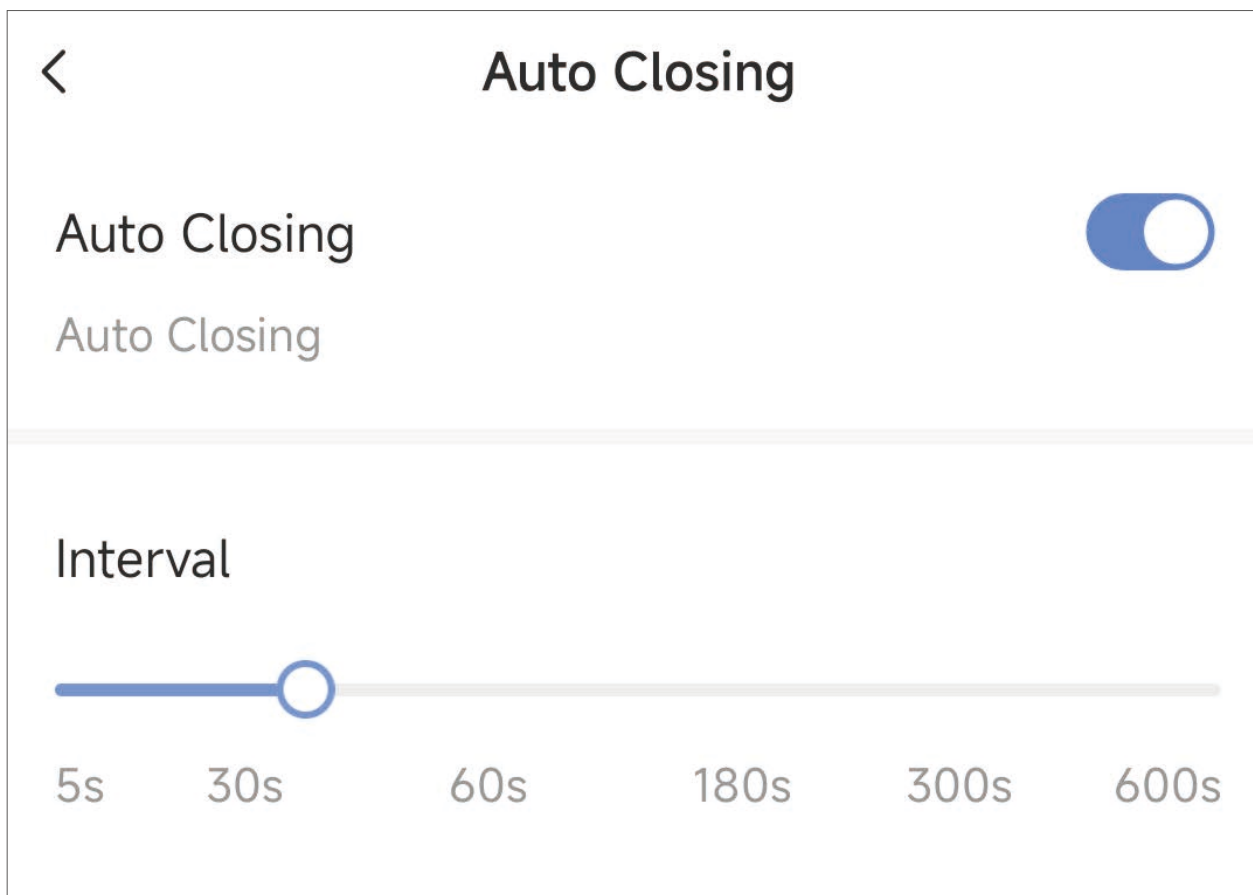

Change the gate opening direction

You should set the correct gate opening direction based on your actual environment.

- If your gate opener is installed on the left (which means that your gate opens to the left), you should select left installation.
- If your gate opener is installed on the right (which means that your gate opens to the right), you should select right installation.

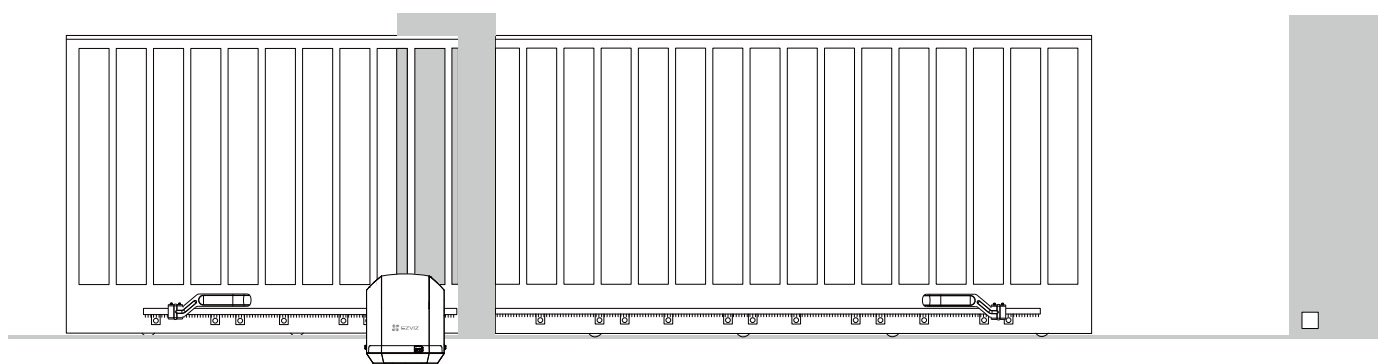

Left Installation

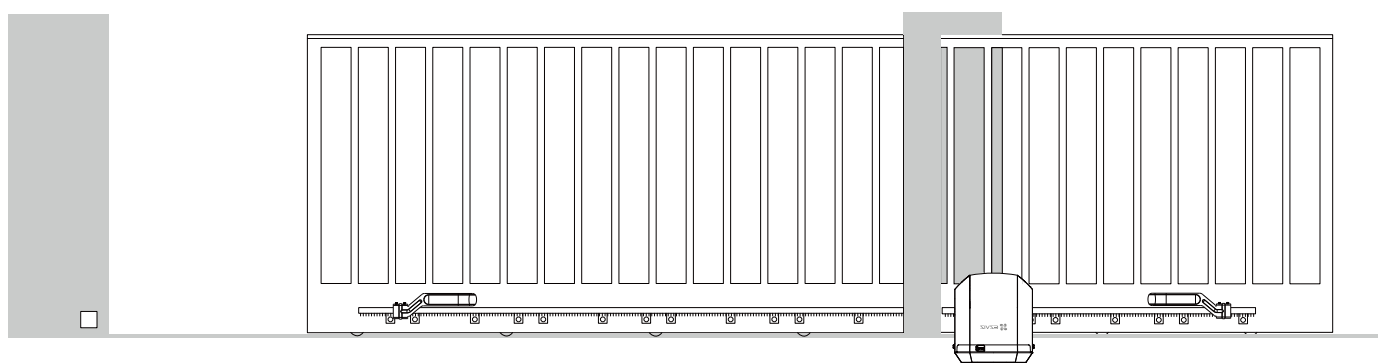

Right Installation

You can set the gate opening direction in two ways:

Method 1 (recommended):

1. On the settings page of the gate opener, tap "Gate Opening/Closing Settings".
2. The gate opening direction you have set during the installation wizard is displayed. You can tap to change the opening direction.



i Changing the gate opening direction will clear the travel learned and the gate opener will re-learn the gate travel. Proceed with caution.

Method 2:

1. Open the cover of the gate opener.
2. Press and hold the Set button for 3 seconds to enter the main menu.
3. Press the Open or Close button until "P2" is shown on the digital display tube.
4. Press the Stop button to enter the "P2" submenu. The current gate opening direction is displayed.

i Refer to the table below for correspondence between the code displayed and the gate opening direction.

| Code Displayed | Gate Opening Direction |
|----------------|------------------------|
| 01 | Left |
| 02 | Right |

5. Press the Open or Close button until your desired gate opening direction is shown on the digital display tube.
6. Press the Stop button. The gate opener system goes back to the main menu.

Configure the custom button setting

If you have connected a customized open controller to your gate opener, you can select a customized opening mode in the EZVIZ app.

1. On the settings page of the gate opener, tap "Gate Opening/Closing Settings".
2. Tap "Customize Button Setting".
3. Select a customized opening mode as needed.

| Option | Description |
|------------|---|
| 1/4 Open | The gate will be 1/4 open after you perform a gate opening operation. |
| 1/2 Open | The gate will be 1/2 open after you perform a gate opening operation. |
| 3/4 Open | The gate will be 3/4 open after you perform a gate opening operation. |
| Fully Open | The gate will be fully open after you perform a gate opening operation. |

Clear and re-learn the gate travel

After you adjust the installation position of the gate opener, you can follow the steps below to manually clear and re-learn the gate travel.

Method 1 (recommended):

1. On the settings page of the gate opener, tap "Gate Opening/Closing Settings".
2. Tap "Travel Re-learning".
3. A prompt message appears. Tap "Continue".

i Performing this travel re-learning operation will clear the existing travel. Proceed with caution.

Method 2:

1. Open the cover of the gate opener.
2. Press and hold the Stop button for 5 seconds.
3. The digital display tube shows a fast-flashing "11" for 3 seconds, indicating that the learned gate travel has been cleared.

Alarm Light Settings

You can turn on or off the sound and flashing light of the alarm light on the settings page of the gate opener.

To turn on or off the sound of the alarm light:

Go to the settings page of the gate opener and tap "Alarm Light Volume".

- Alarm Light Volume
When enabled, the alarm light will make a sound when the gate is opened.
- Do Not Disturb
If you enable this function and set a time period, the alarm light will not make sounds during the specified time period.

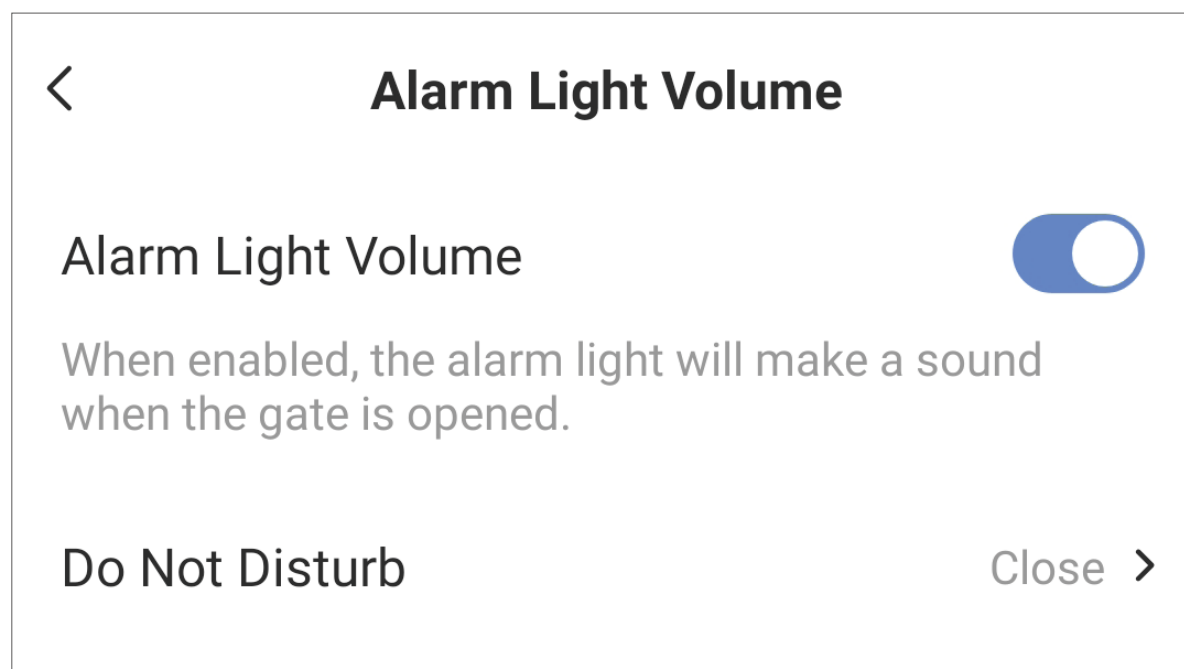

To turn on or off the flashing light of the alarm light:

Go to the settings page of the gate opener and tap "Alarm Light Brightness". After the "Device Flashing Light" switch is turned on, the alarm light will be turned on when the gate is in motion (either opening or closing).

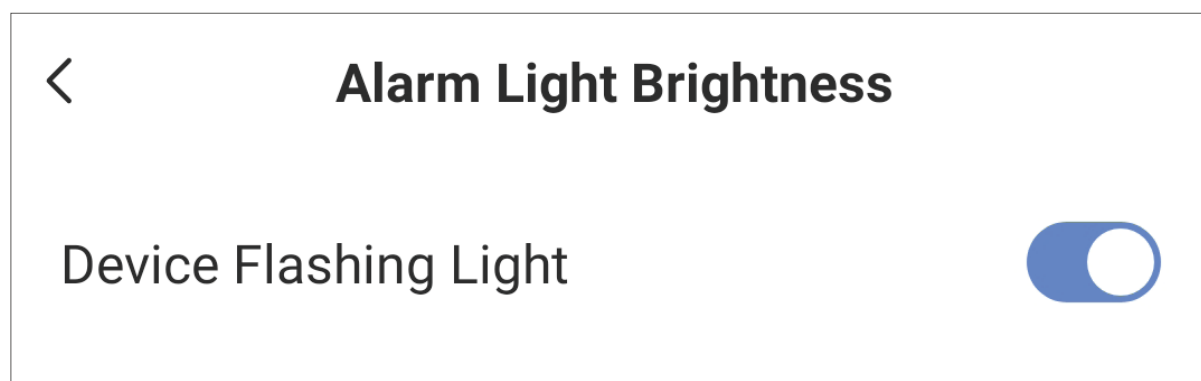

Gate Opener Reset

1. Open the cover of the gate opener.
2. Press and hold the Set button for 8 seconds until the digital display tube shows a fast-flashing "88".
3. After 3 seconds, the gate opener is restored to factory settings.

i **Resetting the gate opener will clear all user data and user-defined settings, such as the learned gate travel, setting parameters, remote controller pairing, and network information, will be cleared.**

2.3 Speaker Settings

To configure speaker settings for the gate opener, follow the steps below:

1. On the detail page of the wireless repeater, tap the device card of the gate opener and select "Speaker Details".
2. On the "Speaker Details" page, you can turn on the Gate Opening Sound Reminder and select a reminder sound as you like.
3. Tap "Save" in the upper-right corner.

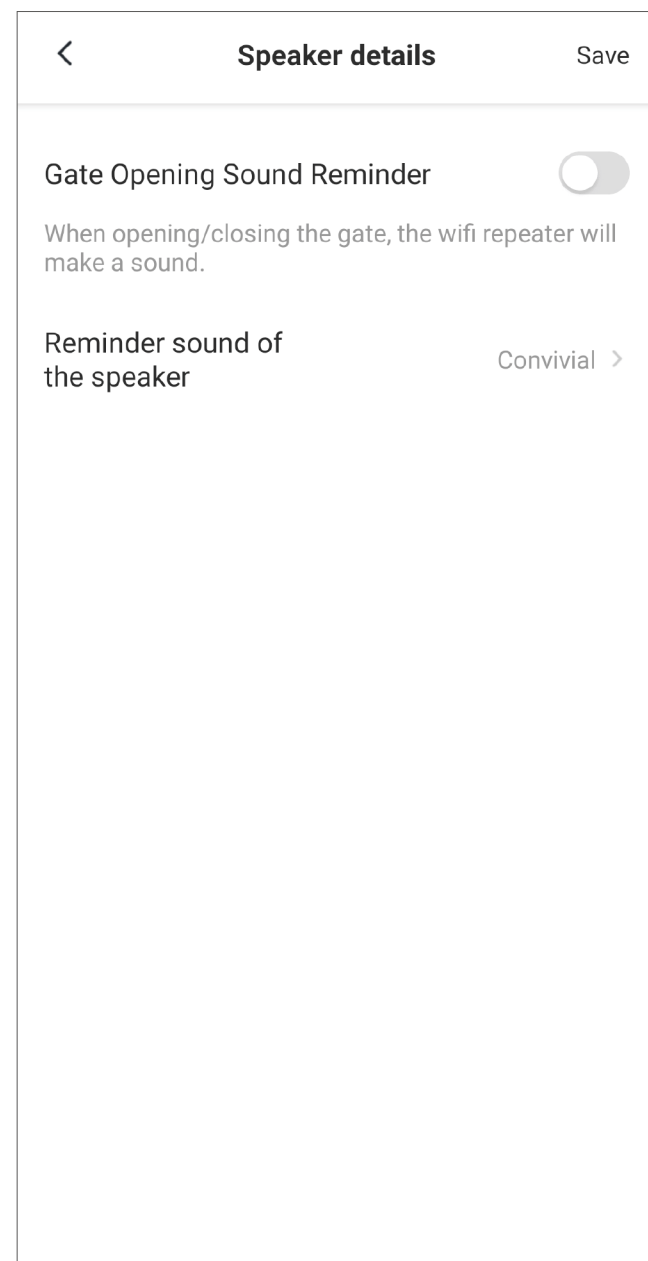
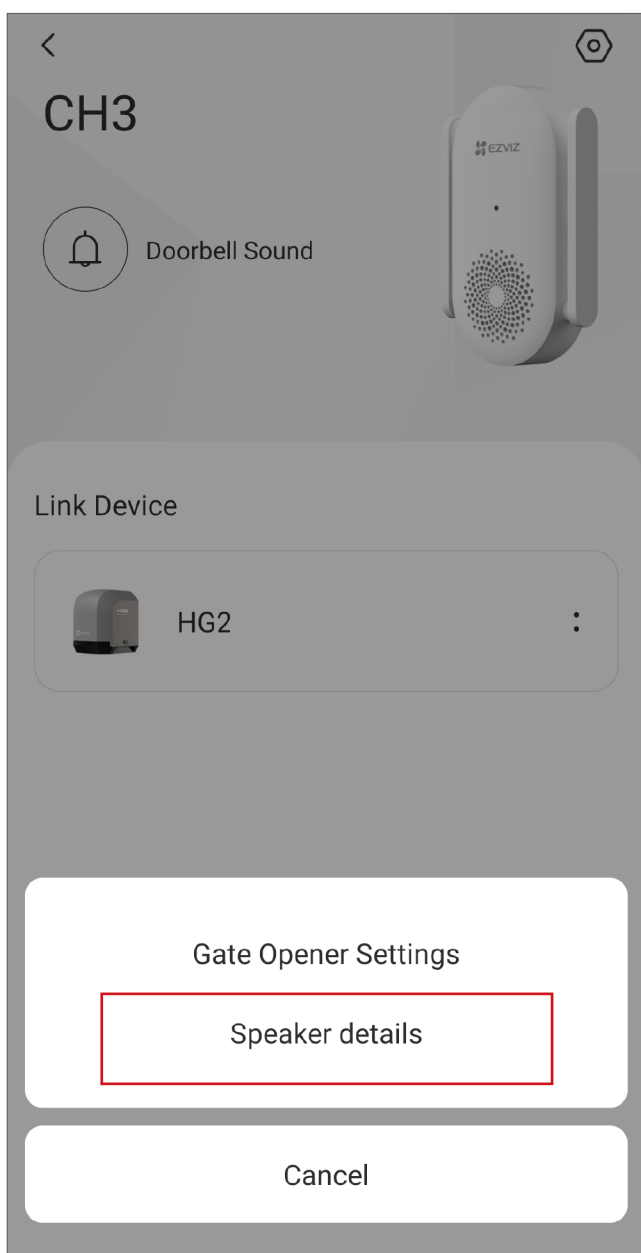

After you enable the Gate Opening Sound Reminder, each time when the gate is opened or closed, the wireless repeater will make a sound.

Error Codes

| Error Code | Meaning | User Action | Gate opening and closing normal? |
|------------|---------------------------|--|----------------------------------|
| E0 | Failed to start self-test | Contact the EZVIZ official customer service. | No |
| E1 | Rotor blocked | <ol style="list-style-type: none"> 1. Check whether obstacles exist on the guide rail and remove them. 2. Check whether the gate opener and gear racks are installed correctly. Specifically, use the key supplied to unlock the gate opener and open and close the gate completely to check for any obvious resistance. If necessary, adjust the installation position of the gate opener. 3. If the error persists, contact EZVIZ customer service. | No |
| E2 | Abnormal Current Sampling | Contact the EZVIZ official customer service. | No |
| E3 | Battery Undervoltage | <ol style="list-style-type: none"> 1. Open the circuit breaker of the gate opener or the main circuit breaker in your home to disconnect the gate opener from power. 2. Remove the gate opener cover. Unplug the battery cable and then insert it back. 3. If the error persists, you are advised to buy an EZVIZ battery and install it on the gate opener. 4. If you have any other questions, contact EZVIZ customer service. | No |
| E4 | Operation timeout | <ol style="list-style-type: none"> 1. Check whether the pinion and rack system on the gate opener is loose or otherwise improperly installed. 2. Check whether the limit sheet metal are dislocated. 3. If you have any other questions, contact EZVIZ customer service. | No |
| E5 | Obstacles persist | <ol style="list-style-type: none"> 1. Check whether obstacles exist on the guide rail and remove them. 2. If the error persists, you are advised to buy EZVIZ motor sensors to replace the faulty sensors. 3. If you have any other questions, contact EZVIZ customer service. | No |
| E6 | Obstruction Fault | <ol style="list-style-type: none"> 1. Check whether obstacles exist on the guide rail and remove them. 2. Check whether the gate opener and gear racks are installed correctly. Specifically, use the key supplied to unlock the gate opener and open and close the gate completely to check for any obvious resistance. If necessary, adjust the installation position of the gate opener. 3. If the error persists, contact EZVIZ customer service. | No |

| Error Code | Meaning | User Action | Gate opening and closing normal? |
|------------|---|---|----------------------------------|
| E7 | Hall Fault | Contact EZVIZ customer service. | Yes |
| E8 | Power supply undervoltage | Contact EZVIZ customer service. | Yes |
| E9 | Drive Circuit Malfunction | Contact EZVIZ customer service. | No |
| F1 | Battery Overvoltage | <ol style="list-style-type: none"> 1. Open the circuit breaker of the gate opener or the main circuit breaker in your home to disconnect the gate opener from power. 2. Remove the gate opener cover. Unplug the battery cable and remove the battery. 3. You are advised to buy an EZVIZ battery and install it on the gate opener. Then install the gate opener cover back. 4. If you have any other questions, contact EZVIZ customer service. | Yes |
| F2 | Overvoltage in High-Voltage System | Contact EZVIZ customer service. | Yes |
| F3 | First-level overcurrent (critical) | Contact EZVIZ customer service. | No |
| F4 | Second-level overcurrent | Contact EZVIZ customer service. | No |
| F5 | First-level over temperature (HaLow module) | <ol style="list-style-type: none"> 1. Wait 10 minutes before opening or closing the gate. 2. If you have any other questions, contact EZVIZ customer service. | Yes |
| F7 | Wi-Fi/HaLow offline | <ol style="list-style-type: none"> 1. Check whether the distance between the gate opener and the wireless repeater meets the requirement: "The wireless repeater should be installed within 30 meters (with two walls in between at most and no other obstructions) from the gate opener." 2. You can re-install the wireless repeater closer to the gate opener. 3. If you have any other questions, contact EZVIZ customer service. | Yes |
| F8 | Device Offline | <ol style="list-style-type: none"> 1. Check whether the network connection between the gate opener and the wireless repeater is normal. 2. If you have any other questions, contact EZVIZ customer service. | Yes |
| F9 | Control Frequency exceeds the limit | <ol style="list-style-type: none"> 1. The gate has been opened and closed too frequently and over temperature protection has been triggered on the gate opener. Please wait 40 minutes before opening and closing the gate again. 2. If you have any other questions, contact EZVIZ customer service. | No |

Technical Data

| Motor | |
|----------------------------------|---|
| Motor type | 24V DC |
| Input power | 230V AC 50Hz; 14.6V DC by backup battery |
| Maximum power | 220W |
| Rated operating time | 15 minutes |
| Maximum frequency of movements | 20 cycles per hour 480 cycles per day * Tested under 3-meter gate, device operating at low speed setting. |
| Lock power output | DC 12V 1.5A |
| Photocellule input | Max 2 pairs, no polarity |
| Continuous open/stop/close input | Normal open dry contact, allow multiple inputs |
| Open | Normal open dry contact, allow multiple inputs |
| Stop | Normal close dry contact default, switchable to normal open dry contact in app |
| Alarm light output | DC 10-18V 700mA |
| Light output | 230VAC Maximum power 100W |
| Operation conditions | -30°C to 60°C, humidity 95% or less (non-condensing) |
| Protection rating | IP55 |
| Number of remote controllers | Maximum 8 |

| Alarm Light | |
|----------------------|---|
| Connection Method | Wired connection (2-wired), Digital signal transmission |
| Operation conditions | -30°C to 55°C, humidity 95% or less (non-condensing) |
| Protection rating | IP55 |

| Wi-Fi HaLow Repeater | |
|-----------------------------|---|
| Power supply | AC 110-240V |
| Wi-Fi standard | Wi-Fi 6: IEEE802.11b, 11g, 11a, 11n, 11ac, 11ax; Wi-Fi HaLow: IEEE802.11ah |
| Module | Wi-Fi 6 2.4GHz/5GHz HaLow |

| Photocellule | |
|---------------------|------------------------------------|
| Content | 1 TX transmitter and 1 RX receiver |
| Power supply | 12V DC |
| Maximum rated power | 0.8 W (TX&RX) |
| Distance | 8m MAX |

Photocellule

| | |
|----------------------|--|
| Operation conditions | -30°C to 60°C, humidity 95% or less (non-condensing) |
| Protection rating | IP55 |

Remote Controller

| | |
|----------------------|--|
| Frequency | 433MHz |
| Open field range | 60m |
| Power | 3V - CR2032 |
| Button | 4 buttons (extra 1 reset button inside) |
| Battery lifetime | 1 year based on 20 uses of 2 seconds. per day |
| Operation conditions | -10°C to 45°C, humidity 95% or less (non-condensing) |

Gear Rack

| | |
|----------|---------------------------------|
| Length | 0.33m |
| Type | M4 |
| Material | PA66 (nylon) + GF (glass fiber) |

Warranty

The warranty period for the gate opener is 5 years.

The warranty period for the photocellules, the remote controllers, the alarm light, and the wireless repeater is 3 years.

| Name | Warranty Period |
|----------------------|-----------------|
| Sliding Gate Opener | 5 years |
| Photocellules | 3 years |
| Remote Controllers | |
| Alarm Light | |
| Wi-Fi HaLow Repeater | |

i The warranty of this product covers the assurance of its basic functions, and does not include cosmetic damage.

Help & Support

Entry 1 to Help and Support

If you have any questions regarding the use of this product, please view the Help and Maintenance information in the EZVIZ app.

1. Go to the detail page of the gate opener.
2. Tap "Help and Maintenance".
3. On the "Help and Maintenance" page, you can view the installation guide and fault assistance, as well as the FAQ.

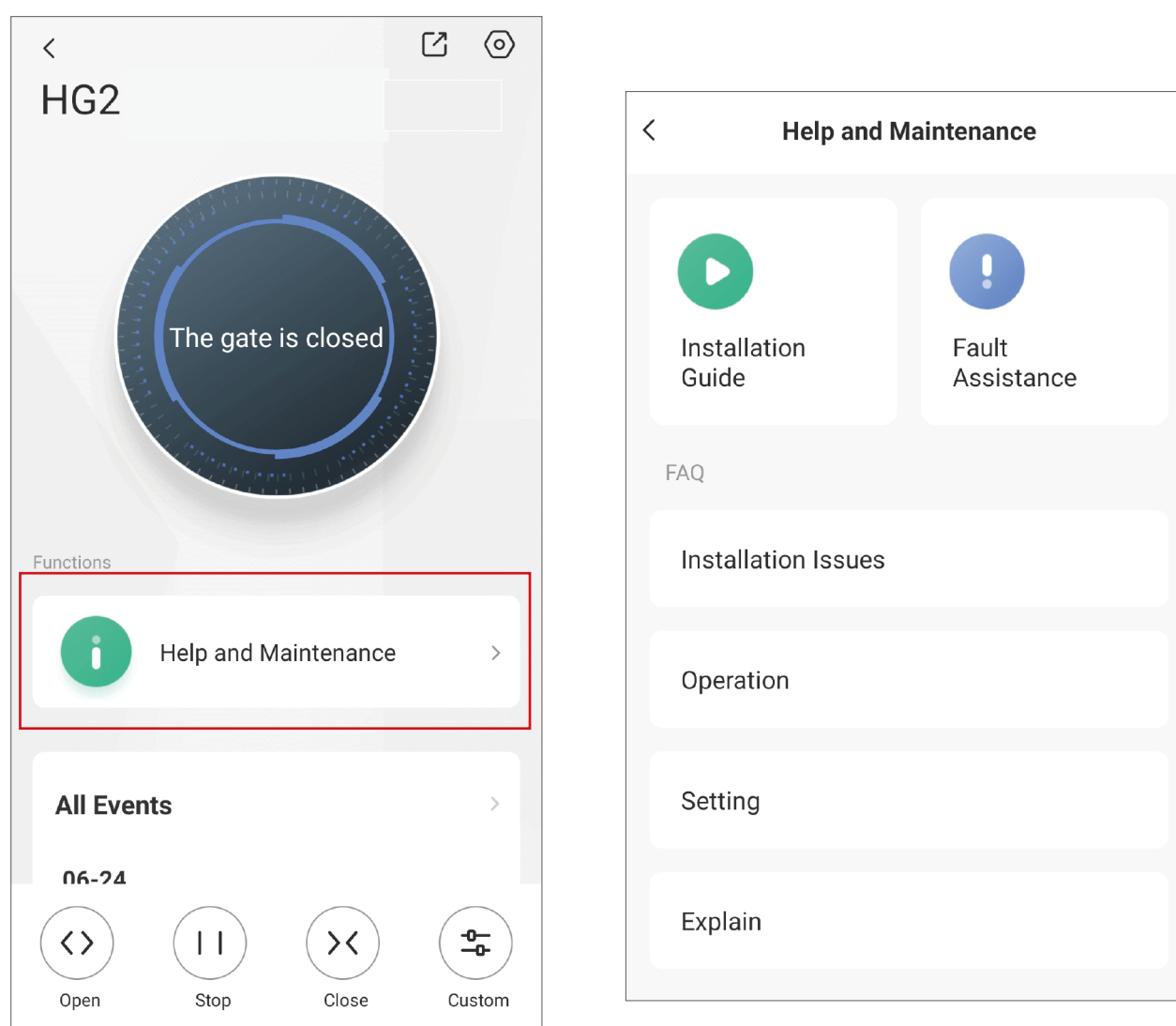

Entry 2 to Help and Support

You can also click the link (<https://www.ezviz.com/page/hg2-400-choose-language>) or scan the QR code on the cover of this user manual to watch the tutorial videos of this product on EZVIZ's official website.

Entry 3 to Help and Support

If you have any further questions, please contact the EZVIZ official customer service at support@ezviz.com.

Appendix

1. Rechargeable Lithium Ion Battery

The battery type of the device: Portable battery.

| Hazardous Ingredients (Chemical Name) | CAS No. | Concentration Ranges | Chemical Formula |
|--|-------------|-------------------------|--|
| Nickel-cobalt-manganese lithium | 346417-97-8 | 36.6 | LiNiCoMnO ₂ |
| Graphite | 7782-42-5 | 19.8 | C |
| PVDF | 24937-79-9 | 0.4 | (CH ₂ -CF ₂) _n |
| CMC | 9000-11-7 | 0.3 | C ₈ H ₁₆ NaO ₈ |
| Acetylene black | 1333-86-4 | 0.9 | C |
| Styrene-butadiene rubber | 9003-55-8 | 0.4 | (C ₈ H ₈ .C ₄ H ₆) _x |
| PP | 9003-07-0 | 0.7 | (C ₃ H ₆) _n |
| Lithium hexafluorophosphate | 21324-40-3 | 2.0 | LiF ₆ P |
| Ethylene carbonate | 96-49-1 | 2.0 | C ₃ H ₄ O ₃ |
| Ethyl methyl carbonate | 623-53-0 | 1.0 | C ₄ H ₈ O ₃ |
| Dimethyl carbonate | 616-38-6 | 6.8 | C ₃ H ₆ O ₃ |
| Copper | 7440-50-8 | 7.6 | Cu |
| Aluminum | 7429-90-5 | 3.5 | Al |
| Nickel | 7440-02-0 | 0.7 | Ni |
| Iron | 7439-89-6 | 17.3 | Fe |

2. Information for Private Households

1. Separate collection of waste equipment: Electrical and electronic equipment that has become waste is referred to as waste equipment. Owners of waste equipment must dispose of it separately from unsorted municipal waste. In particular, waste equipment does not belong in household waste, but in special collection and return systems.
2. Batteries and rechargeable batteries as well as lamps: Owners of waste equipment shall, as a rule, separate waste batteries and rechargeable batteries that are not enclosed in the waste equipment, which can be removed from the waste equipment without being destroyed, from the waste equipment before handing them in at a collection point. This does not apply if waste equipment is prepared for reuse with the participation of a public waste management authority.
3. Options for returning waste equipment: Owners of waste equipment from private households can return it free of charge to the collection points of the public waste management authorities or to the take-back points set up by manufacturers or distributors within the meaning of the Electrical and Electronics Equipment Law. Stores with a sales area of at least 400 m² for electrical and electronic equipment and those grocery stores with a total sales area of at least 800 m² that offer electrical and electronic equipment several times a year or on a permanent basis and make it available in the market are required to take it back. This also applies in the case of distribution using means of distance communication, if the storage and shipping areas for electrical and electronic equipment are at least 400 m² or the total storage and shipping areas are at least 800 m². Distributors shall, in principle, ensure take-back by providing suitable return facilities at a reasonable distance from the respective end user. The possibility of returning waste equipment free of charge exists for distributors who are obliged to take it back, among other things, if a new similar device that essentially fulfills the same functions is delivered to an end user.
4. Privacy Notice: Waste equipment often contains sensitive personal data. This applies in particular to devices of information and telecommunications technology such as computers and smartphones. In your own interest, please note that each end user is responsible for deleting the data on the waste equipment to be disposed of.
5. Meaning of the symbol "crossed-out wheellie bin": The symbol of a crossed-out wheellie bin regularly depicted on electrical and electronic equipment indicates that the respective device is to be collected separately from unsorted municipal waste at the end of its service life.